

SERIE GFN

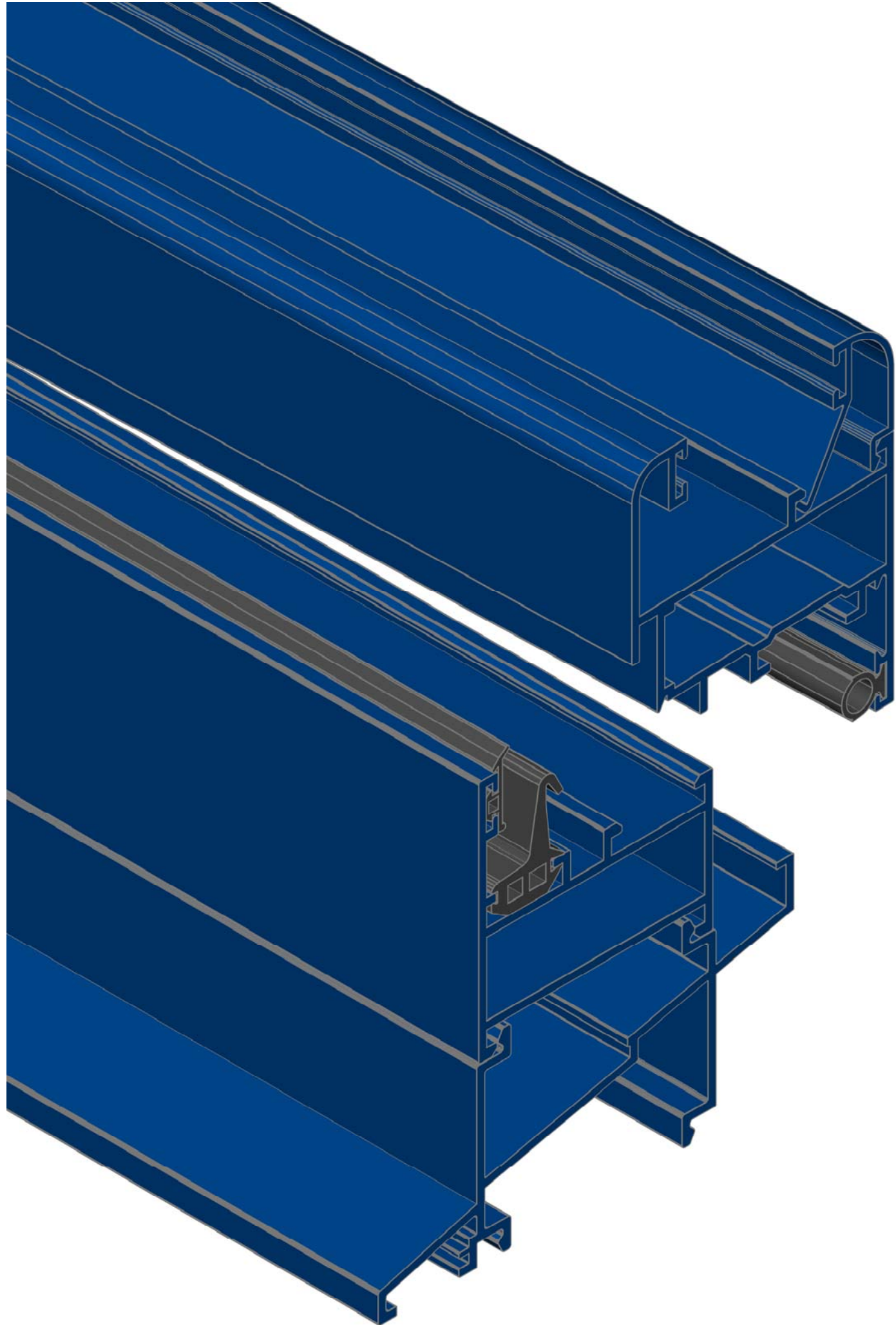

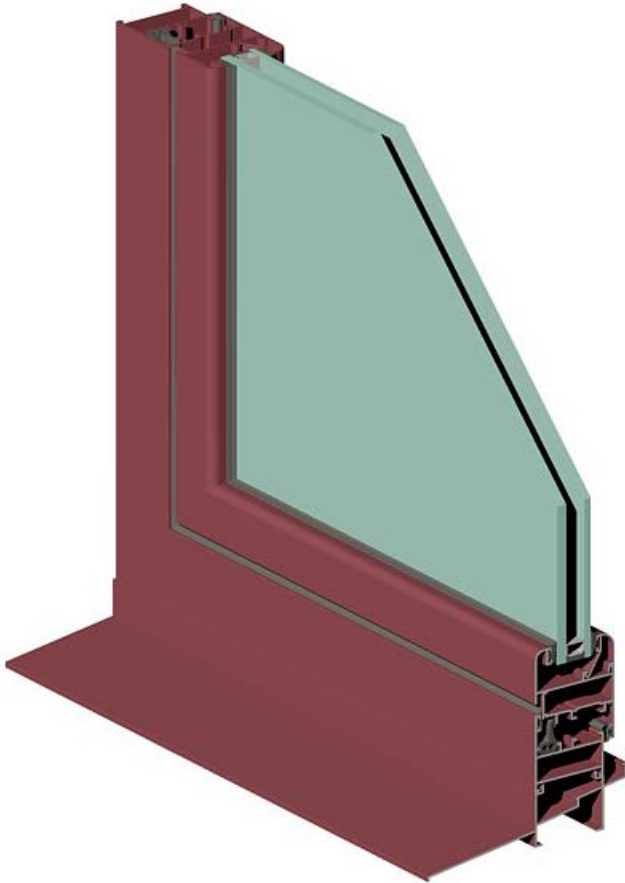

Posibilidades de apertura:

Apertura interior:

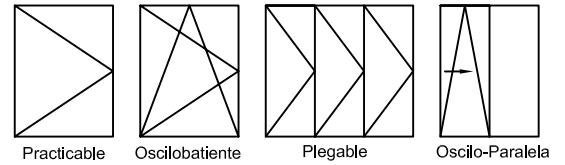

Apertura exterior:

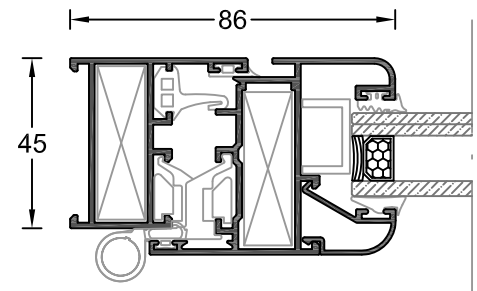
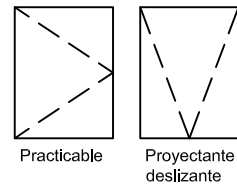

CLASIFICACION SEGUN NORMAS UNE:

Probeta 1230x1480 en dos hojas con cajón de persiana.

- Permeabilidad al aire (UNE-EN 1026): Clase 4 (UNE-EN 12207)
- Estanqueidad al agua (UNE-EN 1027): Clase E900 (UNE-EN 12208)
- Resistencia al viento (UNE-EN 12211): Clase C5 (UNE-EN 12210)

Descripción del sistema:

- Marco 45 mm.
- Hoja 52 mm.
- Perfiles de aluminio extruido EN_6060 (EN573-3 EN755-2)
- Tolerancias dimensionales y espesores EN-120 20.2
- Espesor máximo de acristalado 37 mm.
- Cámara Europea.
- Estanqueidad: perfiles E.P.D.M.

Acabados:

- Lacado imitación madera.
- Lacado colores.
- Anodizado.
- Acabados realizados según normas QUALANOD Y QUALICOAT.

Momentos de inercia:

Perfil:	Referencia:	Inercias (cm ⁴)
	GFN-1	$I_x = 3,107$ $I_y = 8,385$
	GFN-8	$I_x = 9,014$ $I_y = 14,077$
	GFN-21	$I_x = 4,408$ $I_y = 17,117$
	GFN-22	$I_x = 13,2$ $I_y = 32,518$
	GFN-18	$I_x = 5,917$ $I_y = 10,728$
	GFN-4	$I_x = 8,967$ $I_y = 6,992$
	GFN-11	$I_x = 12,606$ $I_y = 18,075$

Aislamiento Térmico:

El recientemente aprobado CÓDIGO TÉCNICO DE LA EDIFICACIÓN, en sus apartados Documento Básico HE (DB) y Documento Básico HR tienen por objeto establecer reglas y procedimientos que permiten cumplir las exigencias básicas de ahorro de energía y reducción del ruido exterior. Las secciones de estos documentos se corresponden a los sistemas de carpintería y cerramientos como nuestro sistema GFN cuyas características técnicas se muestran aquí.

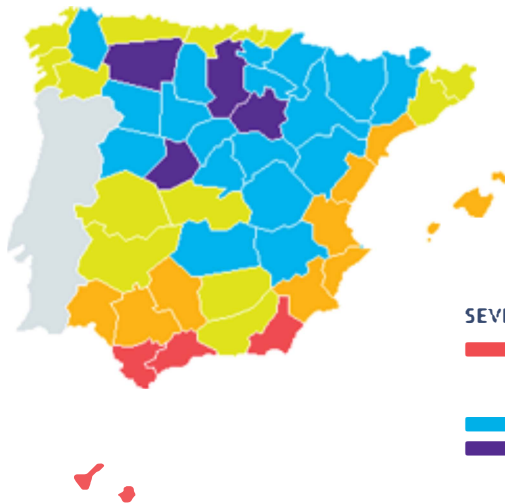

SEVERIDAD CLIMÁTICA DE INVIERNO

ZONA A	5,70 *
ZONA B	5,70 *
ZONA C	4,40 *
ZONA D	3,50 *
ZONA E	3,10 *

Valor medio de la transmitancia del hueco.
Zona climática de la capital de provincia.

Coeficiente carpintería:

U_w desde 1,8 W/m² K



Aislamiento Acústico:

$$R_w (C;C_{tr}) = 32 (-2;-5) \text{ dB}^{(1)}$$

(1) Dato obtenido a partir del ensayo de una ventana de 1230x1480 mm abatible de giro vertical y horizontal inferior practicable al interior de dos hojas derecha con cajón de persiana de 185 mm y utilizando un vidrio 4 / 12 / 4.

GFN-1

Marco ventana

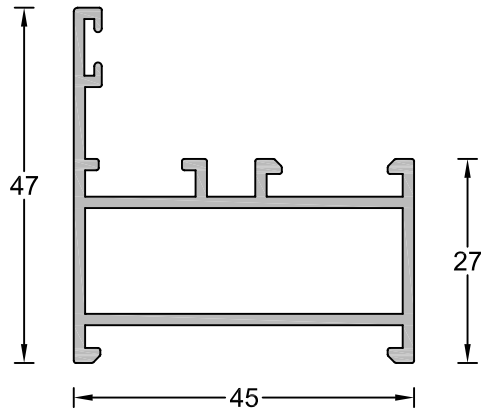

GFN-8

Marco puerta

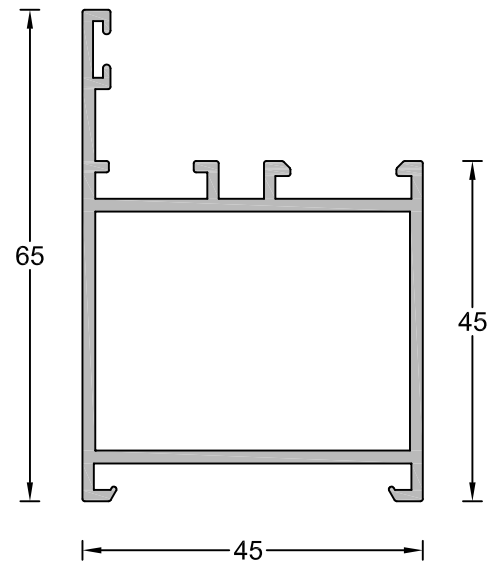

GFN-14

Marco puerta curvo

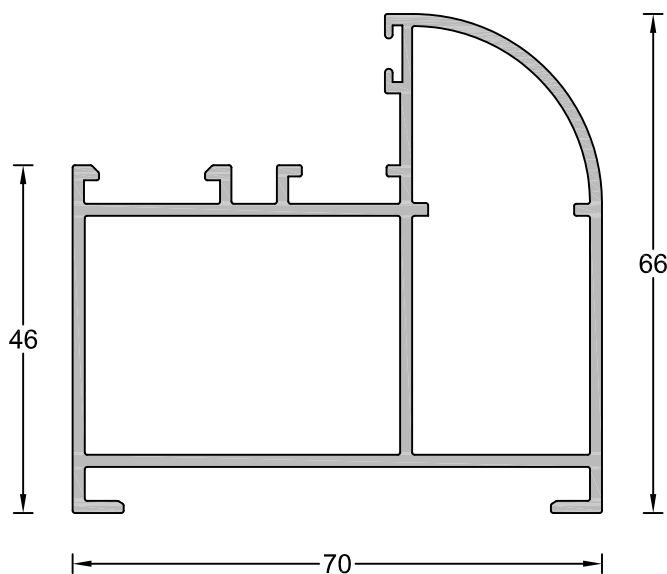

GFN-21

Hoja ventana apertura interior

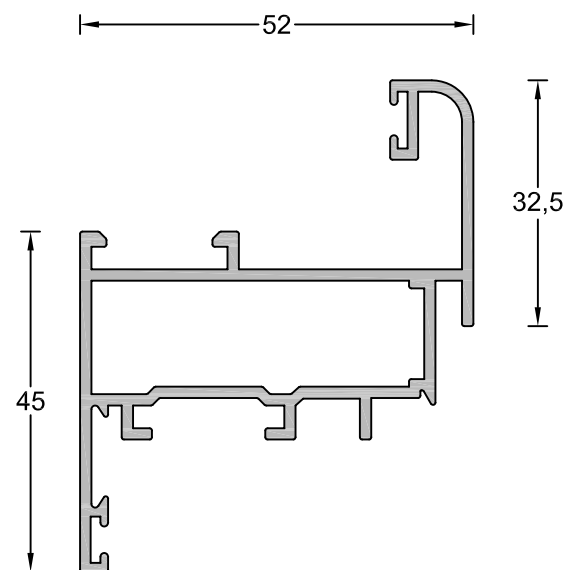

GFN-22 Hoja puerta apertura interior

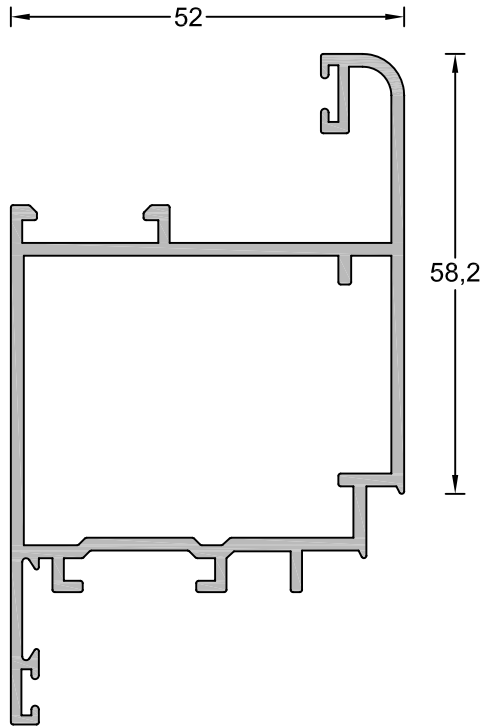

GFN-2 Hoja ventana lisa

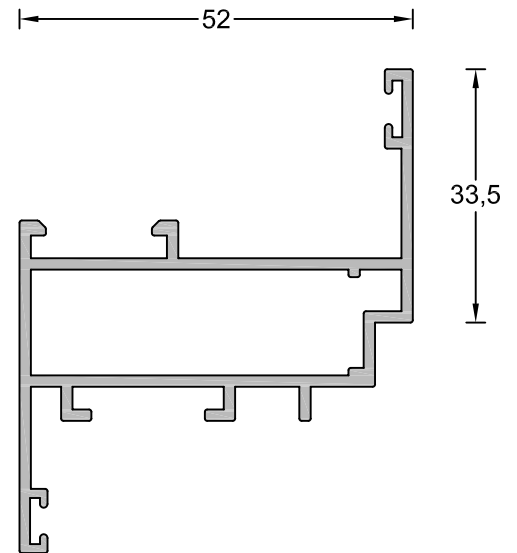

GFN-9 Hoja puerta lisa

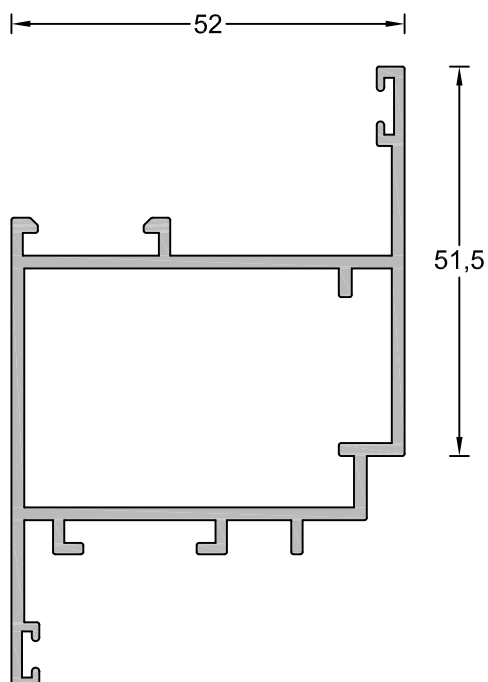

GFN-17 Hoja ventana ap. exterior

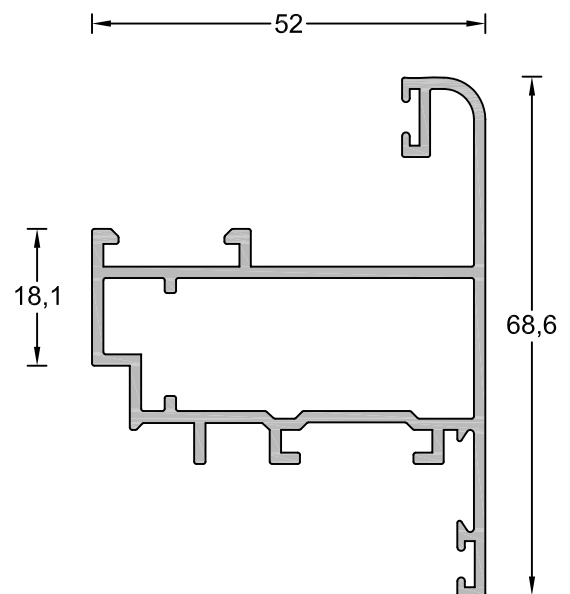

GFN-16 Hoja puerta ap. exterior

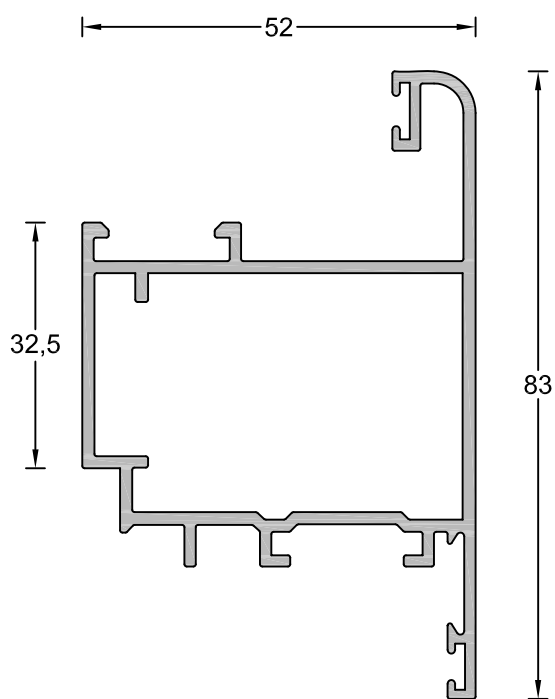

GFN-27 Hoja apertura exterior

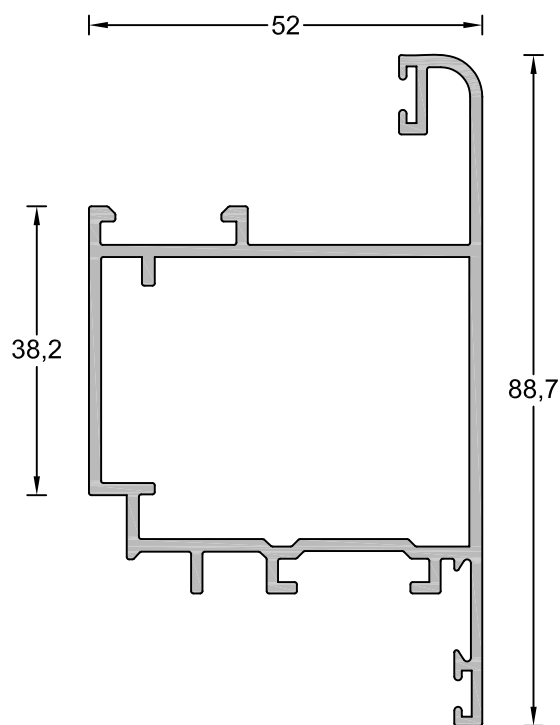

GFN-12 Hoja puerta ap. exterior lisa

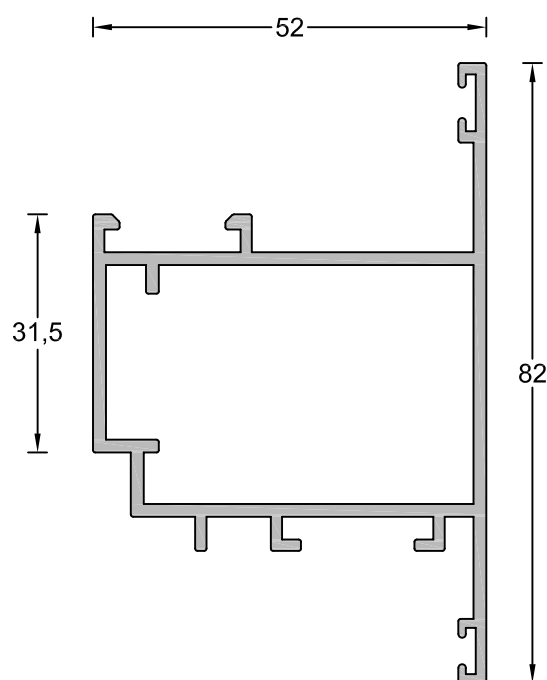

GFN-18 Inversor

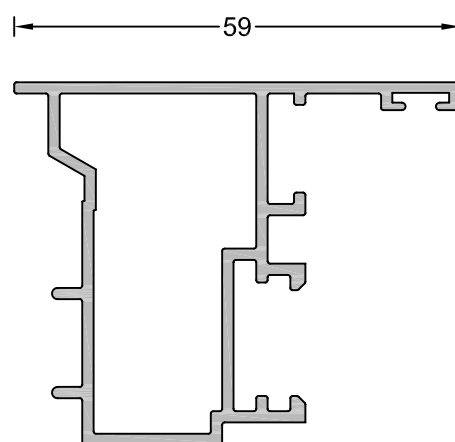

GFN-29

Inversor marco

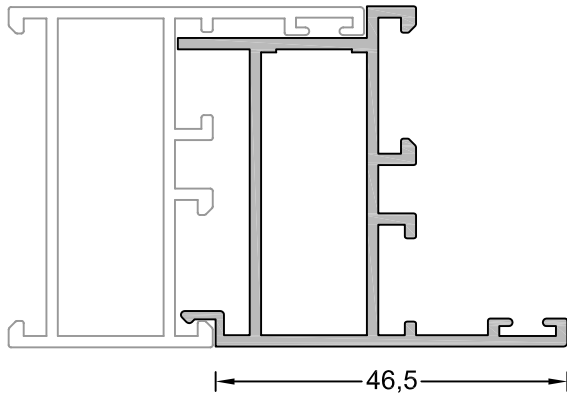

GFN-4

Zanca ventana

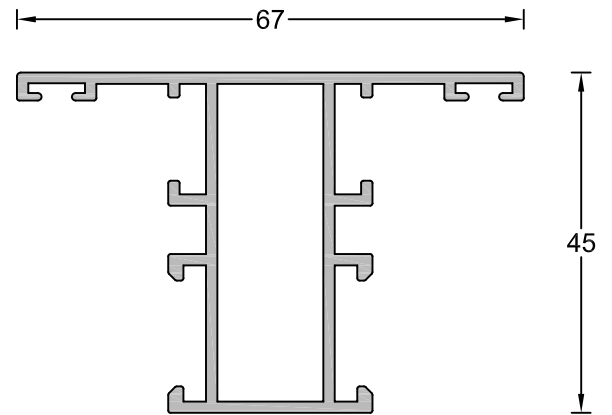

GFN-6

Zanca ventana

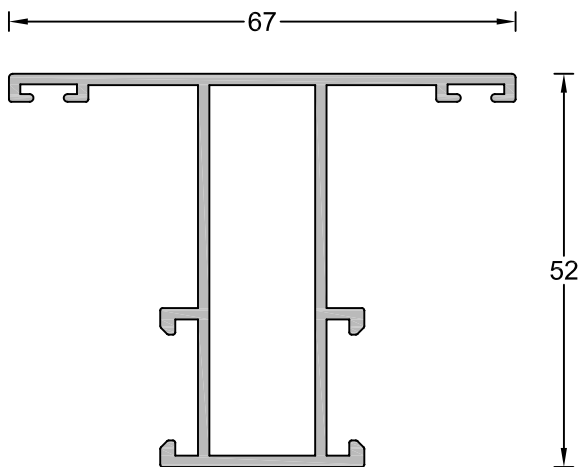

GFN-11

Zanca puerta

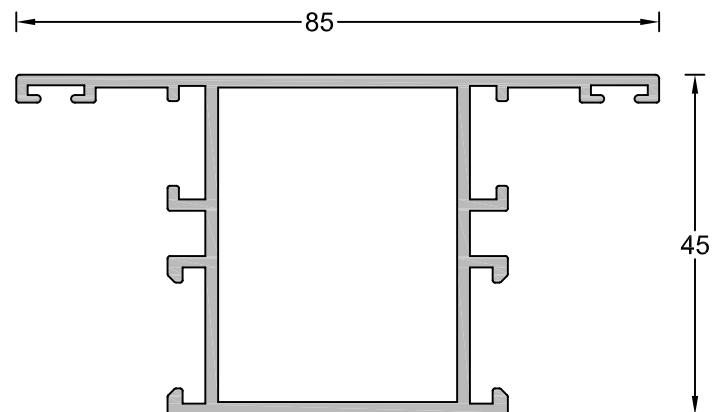

GFN-19

Murete

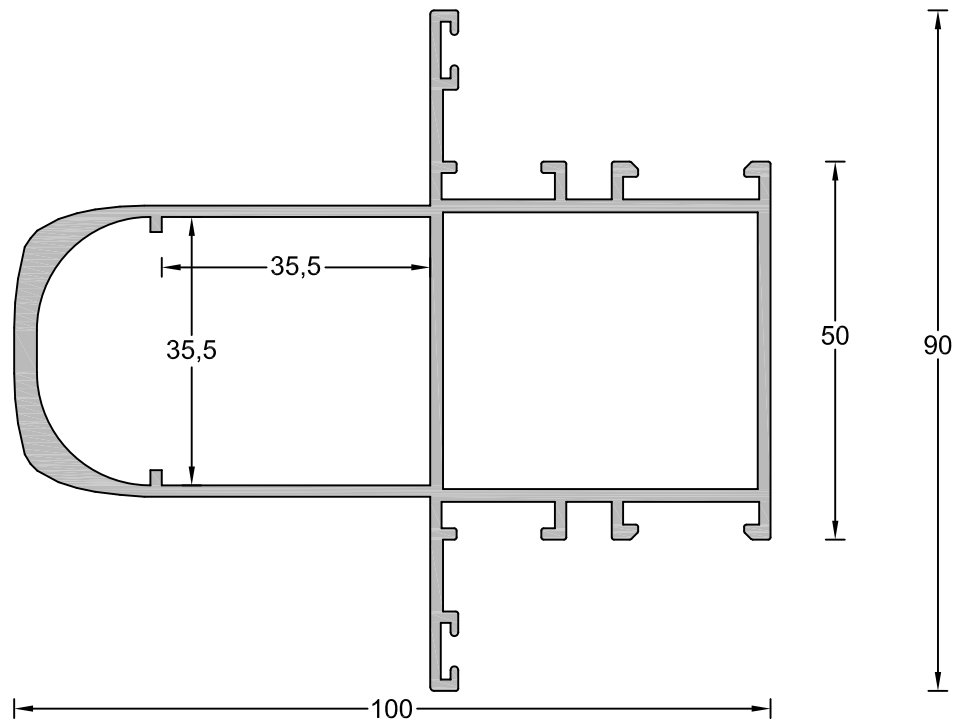

GFN-15

Zócalo

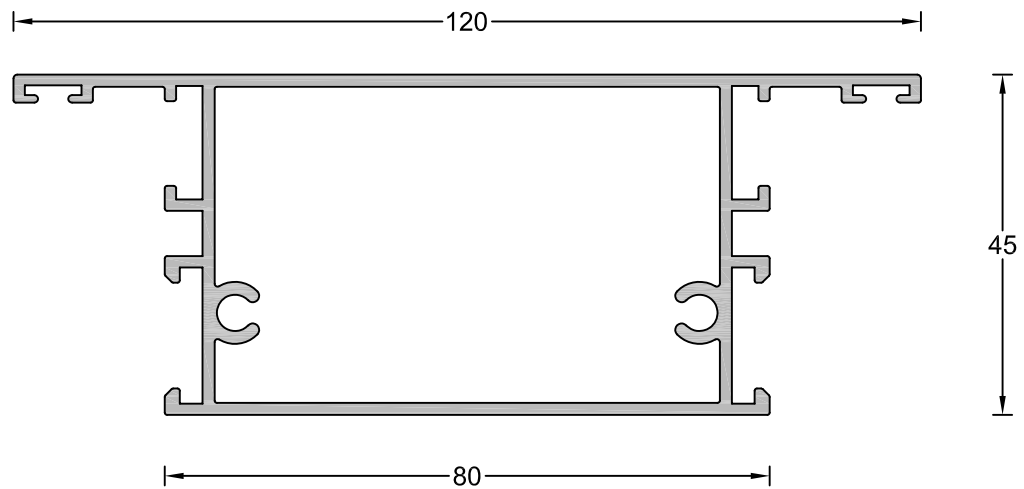

GFN-20

Junquillo

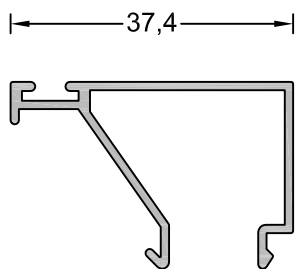

GFN-24

Esquinero redondo

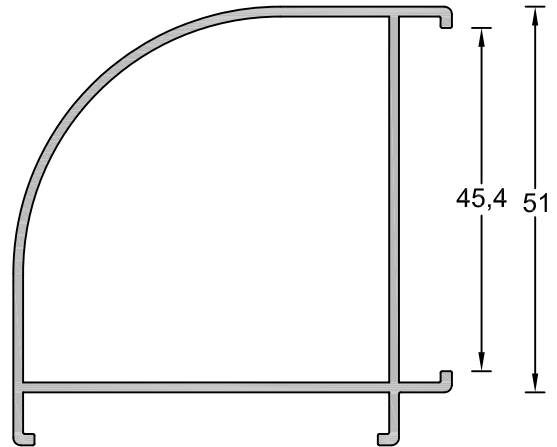

GFN-23

Unión de marcos

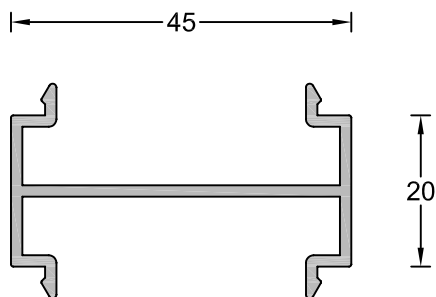

GFN-5

Condensación corta

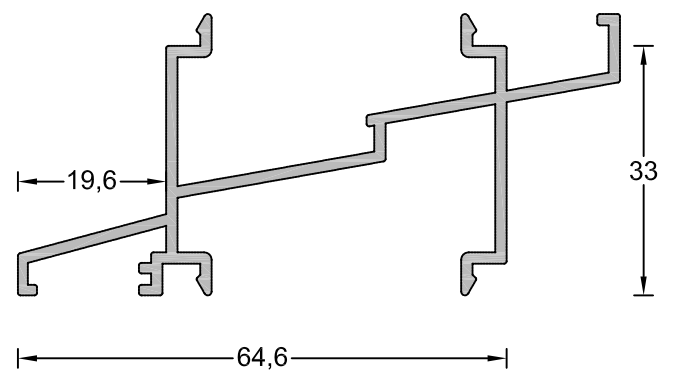

GFN-5 L Condensación larga

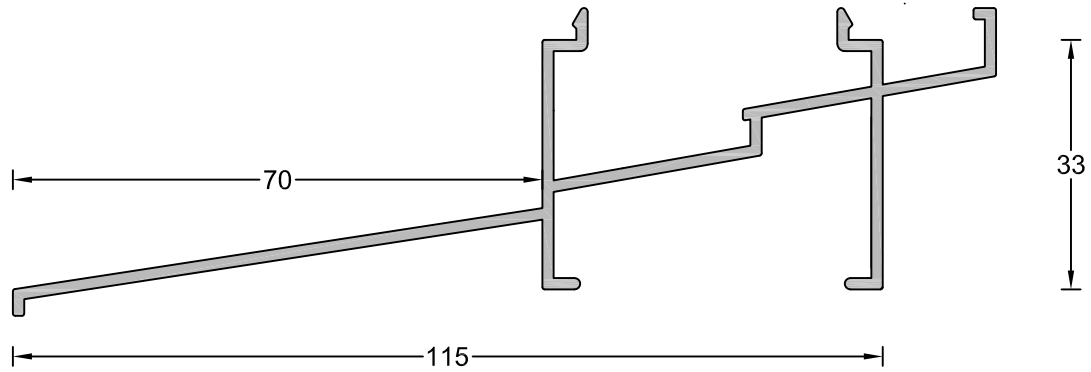

GFN-28 Condensación larga

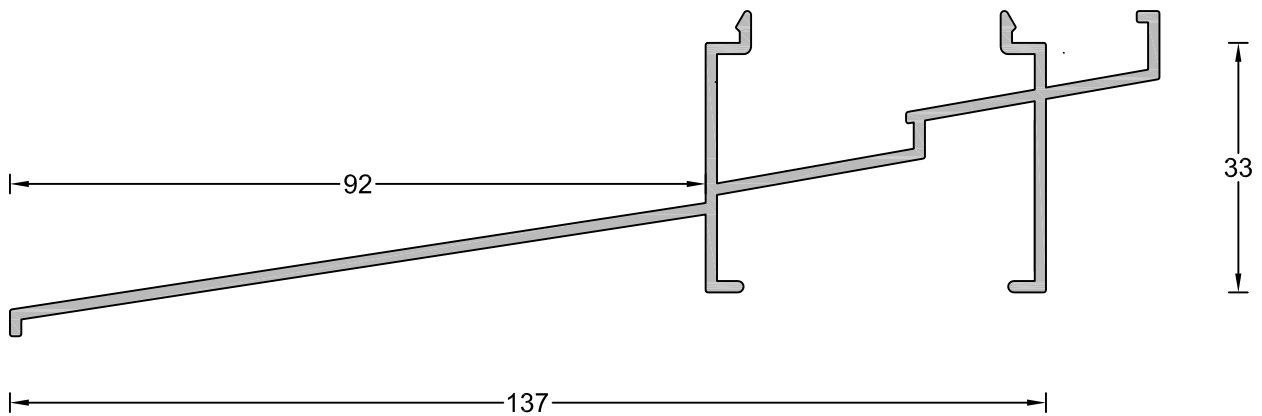

GFN-37 Perfil de vaivén

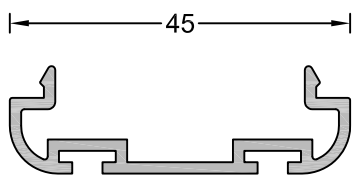

GFN-34 Hoja puerta apertura interior

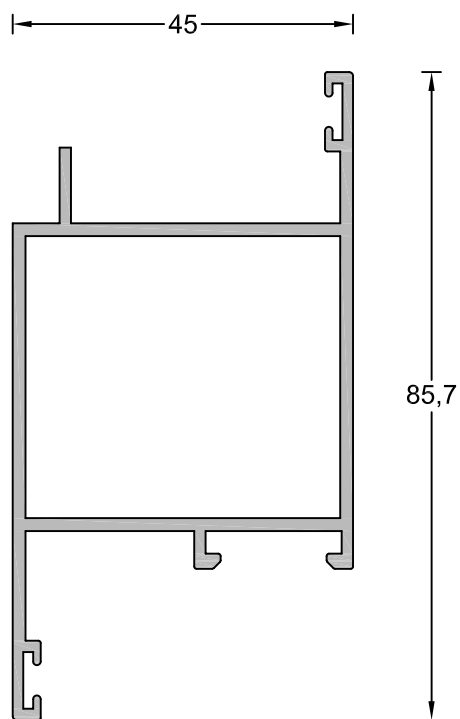

GFN-31 Hoja puerta apertura exterior

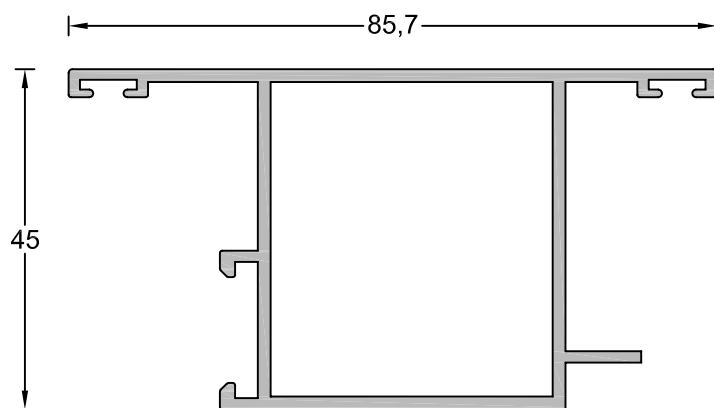

GFN-35 Hoja ancha apertura interior

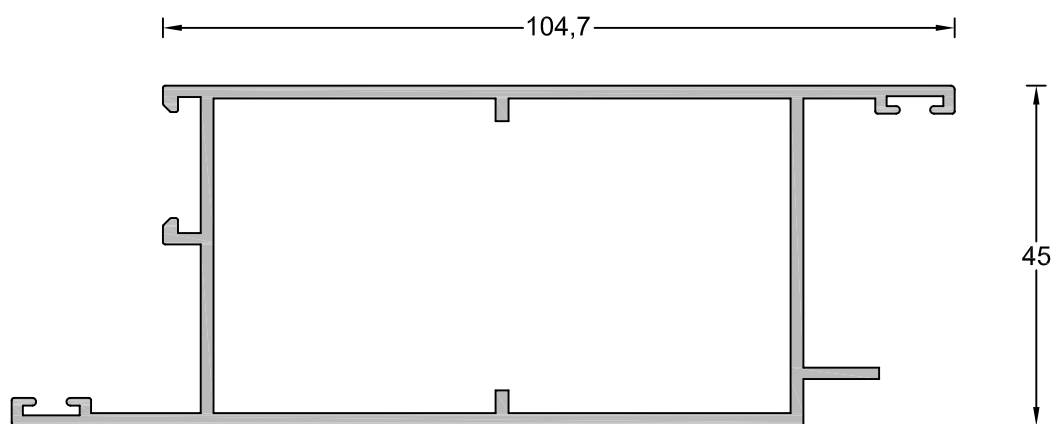

GFN-36 Hoja ancha apertura exterior

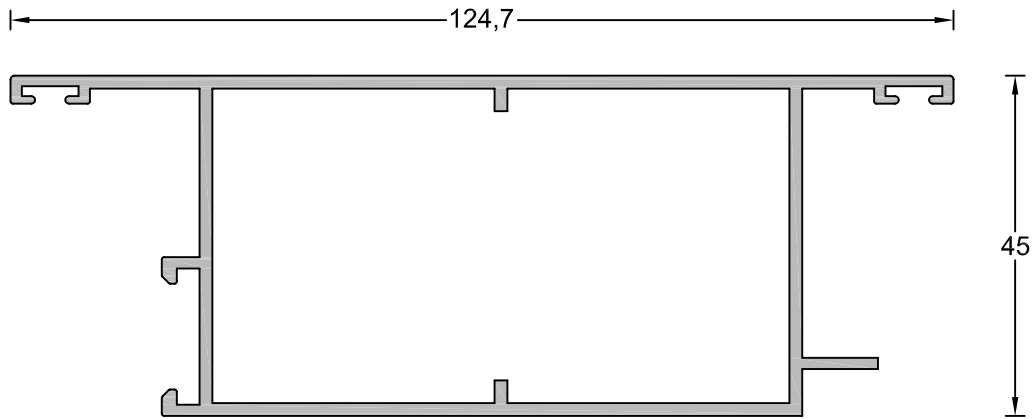

GFN-32 Perfil inversor marco



GFN-33 Inversor

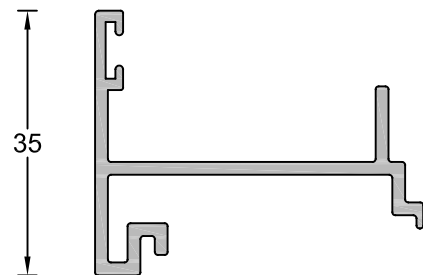

GFN-38

Marco perimetral

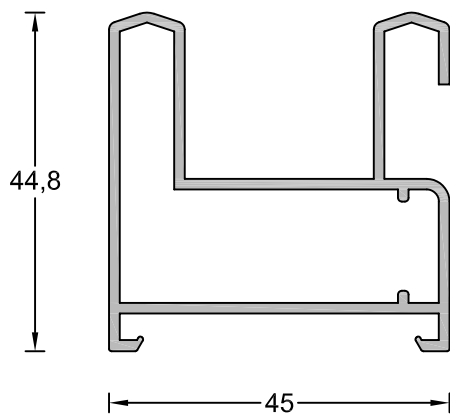

GFN-42

Marco perimetral

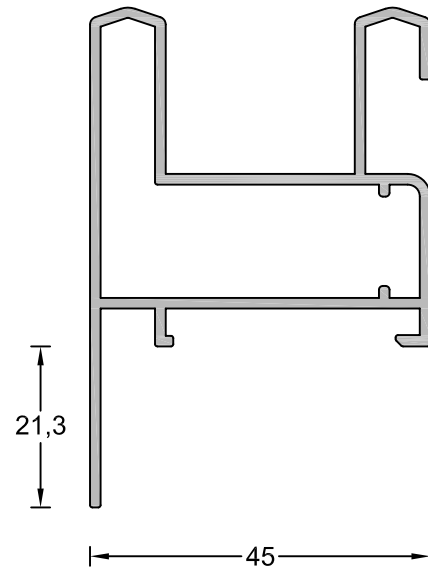

GFN-43

Marco perimetral

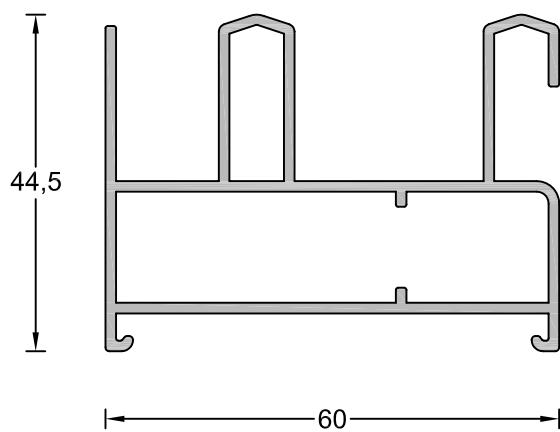

GFN-44

Marco perimetral

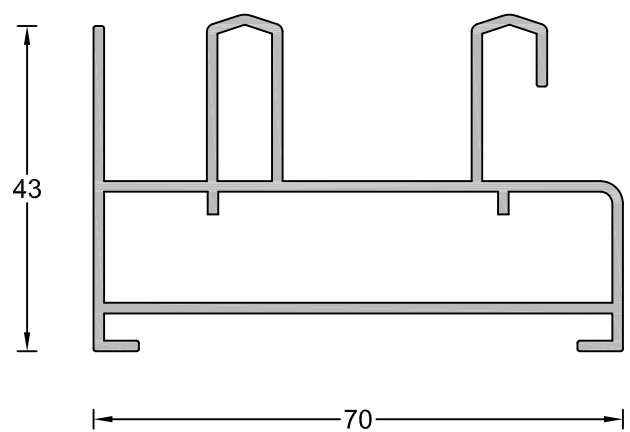

GFN-50

Marco Tri-Rail

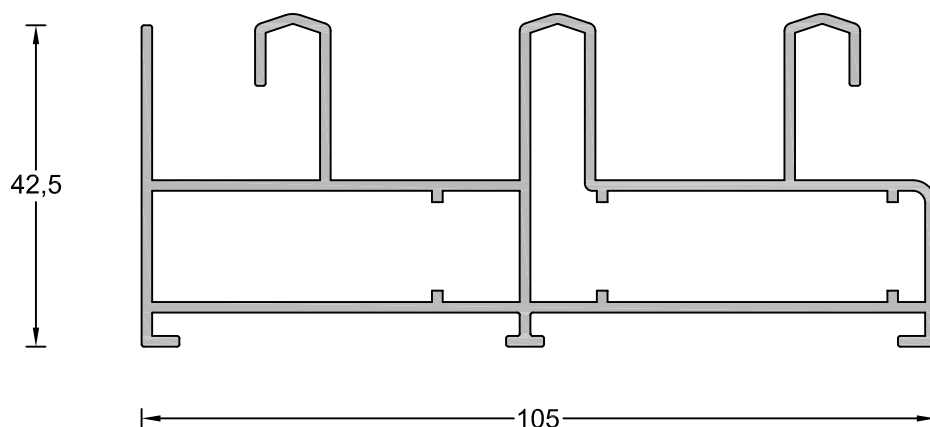

GFN-39

Hoja perimetral

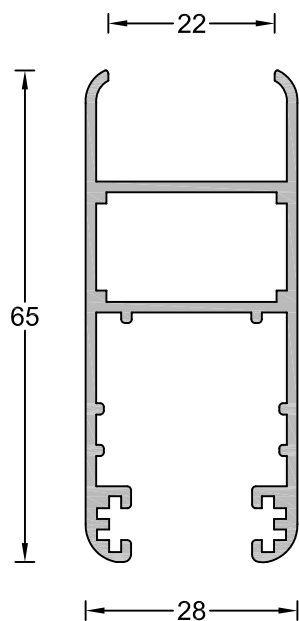

GFN-40

Perfil de cruce

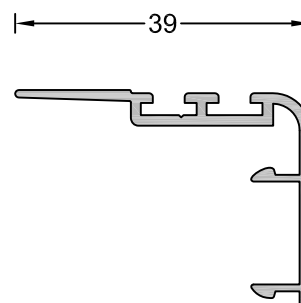

CT-13

Vierteaguas





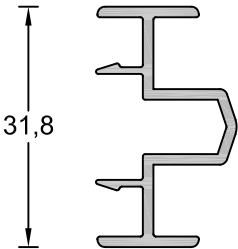
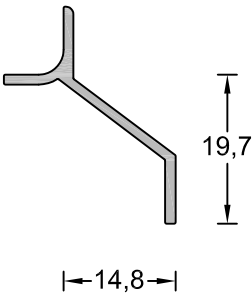



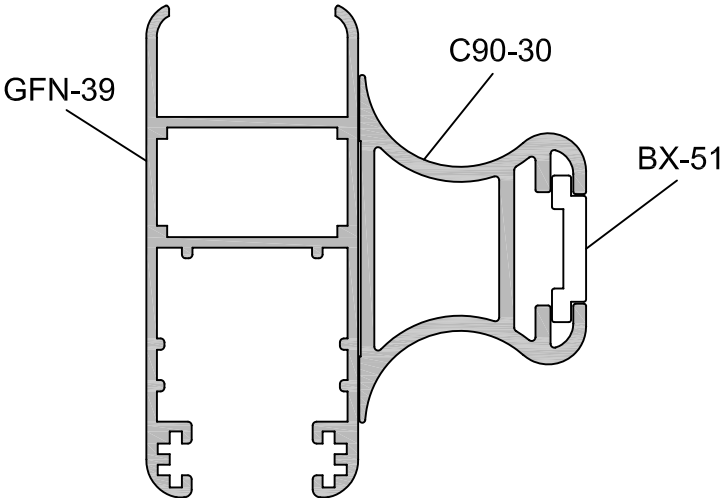





GFN-49

Perfil 4 Hojas



Hoja perimetral con perfil de refuerzo



Referencia	Diseño	Descripción
GFT-35		Junquillo redondo grapa
GFT-34		Junquillo clip redondo
GFT-25		Junquillo clip redondo grapa
GFT-32		Junquillo clip redondo
GFT-26		Junquillo redondo grapa
GFT-33		Junquillo clip redondo
GFT-42		Junquillo clip redondo grapa
GFT-43		Junquillo clip redondo
GFT-20		Junquillo recto
GFT-44		Junquillo recto
GFT-21		Junquillo recto
GFT-22		Junquillo recto 10 m/m.
GFT-23		Junquillo recto
GFT-24		Junquillo recto
GFT-51		Junquillo recto

Huecos para cristal según junquillo

3 mm	8 mm	15 mm	22 mm	25 mm	29 mm	37 mm
GFT-24 	GFT-23 	GFT-22 	GFT-21 	GFT-44 	GFT-20 	GFT-51
	GFT-42 	GFT-26 	GFT-25 		GFT-35 	
	GFT-43 	GFT-33 	GFT-32 		GFT-34 	



Nota: Con hojas GFN-2, GFN-6 y GFN-9, el hueco será 7mm mayor

Nota: L = Ancho ventana, H = Alto ventana.

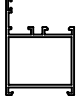
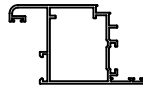

Descuentos para ventana 2 hojas apertura interior

Perfil	Descripción	Medidas	Unidades y Forma
	Marco	L H - 33	2 Unidades 2 Unidades
	Hoja	L/2 - 25 H - 75	4 Unidades 4 Unidades
	Inversor	H - 144	1 Unidad
	Condensación	L	1 Unidad

Nota: L = Ancho ventana, H = Alto ventana, S = Separación que se quiera dejar con el suelo.



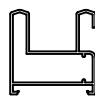
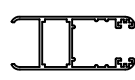

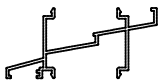
Descuentos para puerta 2 hojas apertura interior			
Perfil	Descripción	Medidas	Unidades y Forma
	Marco	L H	1 Unidad 2 Unidades
	Hoja	L/2 - 43 H - 39 - S	4 Unidades 4 Unidades
	Inversor	H - 74 - S	1 Unidad
	Zócalo	L/2 - 106.5	4 Unidades

Nota: L = Ancho ventana, H = Alto ventana

Descuentos para ventana GFN - CORREDERA			
Perfil	Descripción	Medidas	Unidades y Forma
	Marco	L H - 33	2 Unidades 2 Unidades
	Hoja	L/2 - 2 H - 104	4 Unidades 4 Unidades
	Perfil Cruce	H - 104	2 Unidades
	Condensación	L	1 Unidad

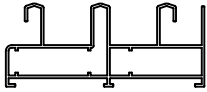
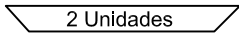
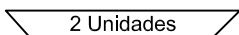
Los descuentos que se incluyen son orientativos. Se recomienda expresamente que proceda a una comprobación previa por parte del cliente.

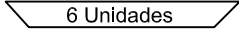
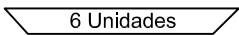
Nota: L = Ancho ventana, H = Alto ventana

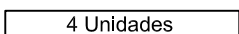
Descuentos para ventana GFN - CORREDERA Tri-Carril			
Perfil	Descripción	Medidas	Unidades y Forma
	Marco	L H	 2 Unidades  2 Unidades
	Hoja	$(L+58) / 3$ H - 70	 6 Unidades  6 Unidades
	Perfil Cruce	H - 70	 4 Unidades

Los descuentos que se incluyen son orientativos. Se recomienda expresamente que proceda a una comprobación previa por parte del cliente.



CÓDIGO: **0803040010**

DESCRIPCIÓN: JBE-P40. Junta batiente exterior

COLOR: Negro MATERIAL: - - UNID.VENTA: Rollo

APLICACIÓN: Junta batiente exterior para colocar en marco.



CÓDIGO: **0803040005**

DESCRIPCIÓN: JBE-GFN. Junta batiente exterior

COLOR: Negro MATERIAL: EPDM UNID.VENTA: Rollo

APLICACIÓN: Junta batiente exterior para colocar en marco.

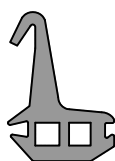

CÓDIGO: **0803040002**

DESCRIPCIÓN: JC-GFN. Junta central

COLOR: Negro MATERIAL: EPDM UNID.VENTA: Rollo

APLICACIÓN: Junta central para Serie GFN



CÓDIGO: **0803050002**

DESCRIPCIÓN: JBI-EX. Junta batiente interior

COLOR: Negro MATERIAL: - - UNID.VENTA: Rollo

APLICACIÓN: Junta batiente interior para colocar en hoja.

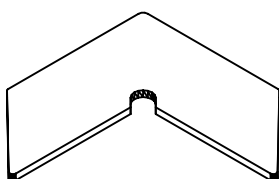

CÓDIGO: **0708090001**

DESCRIPCIÓN: ALG-03. Escuadra alineamiento INOX

COLOR: Inox MATERIAL: Inox UNID.VENTA: Unidad

APLICACIÓN: Escuadra alineamiento

CÓDIGO: **1103170003**

DESCRIPCIÓN: Tapa condensación

COLOR: Negro MATERIAL: -- UNID.VENTA: Bolsa

APLICACIÓN: Juego de tapas para condensación.



CÓDIGO: **0901010001**

DESCRIPCIÓN: Taco inversor GFN

COLOR: Negro MATERIAL: -- UNID.VENTA: Juego

APLICACIÓN: Taco inversor para GFN-18

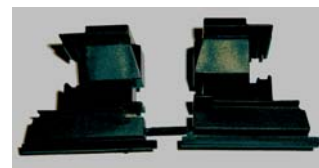

CÓDIGO: **1103170001**

DESCRIPCIÓN: Grapa Junquillo

COLOR: Negro MATERIAL: Nylon UNID.VENTA: Bolsa

APLICACIÓN: Grapa para junquillo

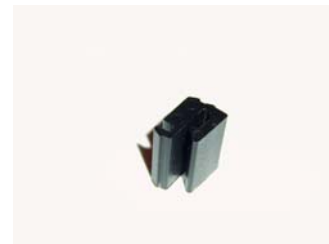

CÓDIGO: **AC 26-4214-C**

DESCRIPCIÓN: Escuadra Aluminio

COLOR: -- MATERIAL: Aluminio UNID.VENTA: Caja

APLICACIÓN: GFN-1

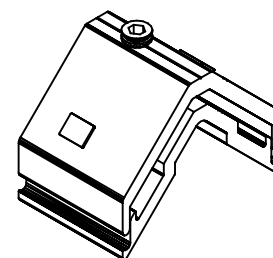

CÓDIGO: **0701070004**

DESCRIPCIÓN: Escuadra 26-4214-150

COLOR: -- MATERIAL: Aluminio UNID.VENTA: Caja

APLICACIÓN: GFN-1, GFN-21, GFN-2.

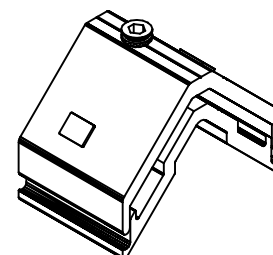

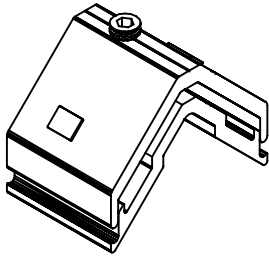

CÓDIGO: **0701070003**

DESCRIPCIÓN: Escuadra 26-3717-150

COLOR: -- MATERIAL: **Aluminio** UNID.VENTA: **Caja**

APLICACIÓN: GFN-17

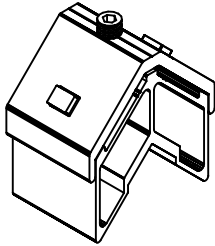

CÓDIGO: **AC 26-4231-C**

DESCRIPCIÓN: Escuadra Aluminio

COLOR: -- MATERIAL: **Aluminio** UNID.VENTA: **Caja**

APLICACIÓN: GFN-8, GFN-14

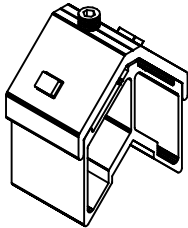

CÓDIGO: **070107011**

DESCRIPCIÓN: Escuadra 26-4236-150

COLOR: -- MATERIAL: **Aluminio** UNID.VENTA: **Caja**

APLICACIÓN: GFN-22, GFN-27, GFN-31, GFN-34, GFN-35, GFN-36

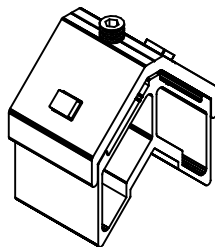

CÓDIGO: **0701070010**

DESCRIPCIÓN: Escuadra 26-4231-150

COLOR: -- MATERIAL: **Aluminio** UNID.VENTA: **Caja**

APLICACIÓN: GFN-8, GFN-14, GFN-16, GFN-9, GFN-12.

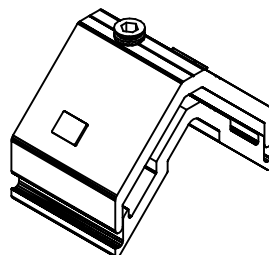

CÓDIGO: **AC 26-3614-C**

DESCRIPCIÓN: Escuadra Aluminio

COLOR: -- MATERIAL: **Aluminio** UNID.VENTA: **Caja**

APLICACIÓN: GFN-38

CÓDIGO: **0701070006**

DESCRIPCIÓN: Escuadra 26-2214-C

COLOR: -- MATERIAL: **Aluminio** UNID.VENTA: **Caja**

APLICACIÓN: GFN-39

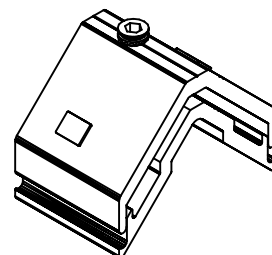

CÓDIGO: **0701070015**

DESCRIPCIÓN: Tope 1418A

COLOR: -- MATERIAL: **Aluminio** UNID.VENTA: **Caja**

APLICACIÓN: GFN-4

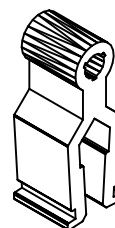

CÓDIGO: **0701070016**

DESCRIPCIÓN: Tope 3118A

COLOR: -- MATERIAL: **Aluminio** UNID.VENTA: **Caja**

APLICACIÓN: GFN-11

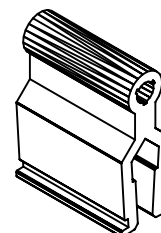

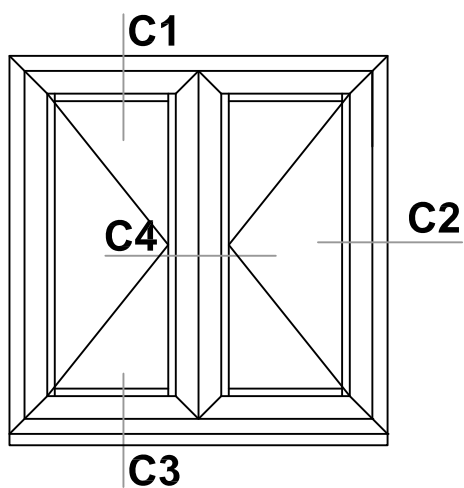

Ventana 2 hojas apertura interior

Corte 1

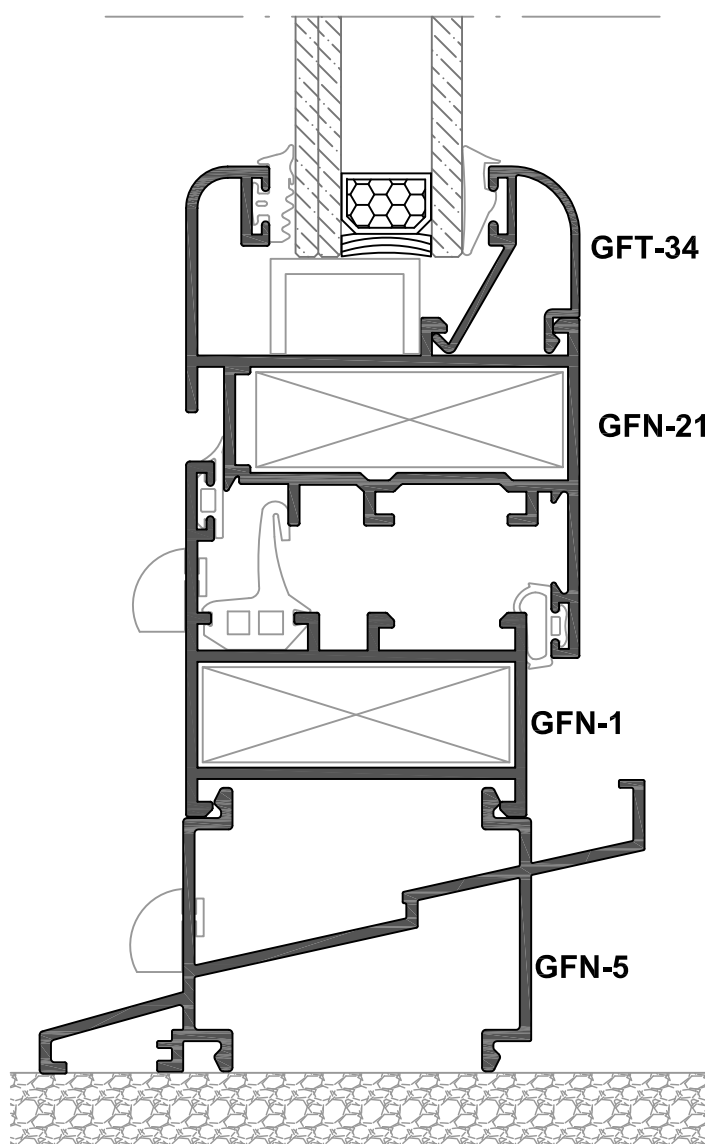
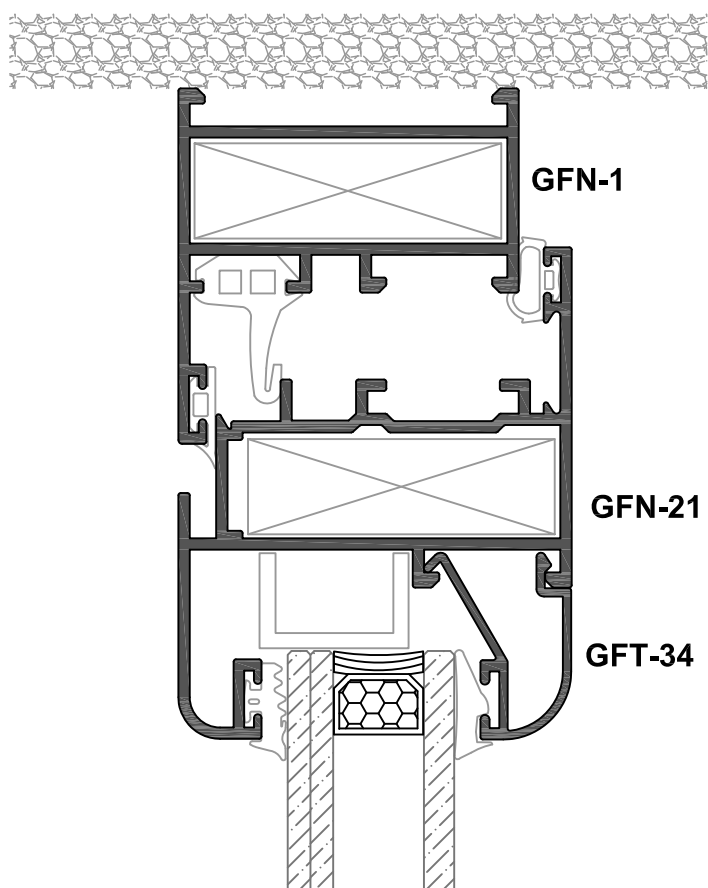

Corte 3

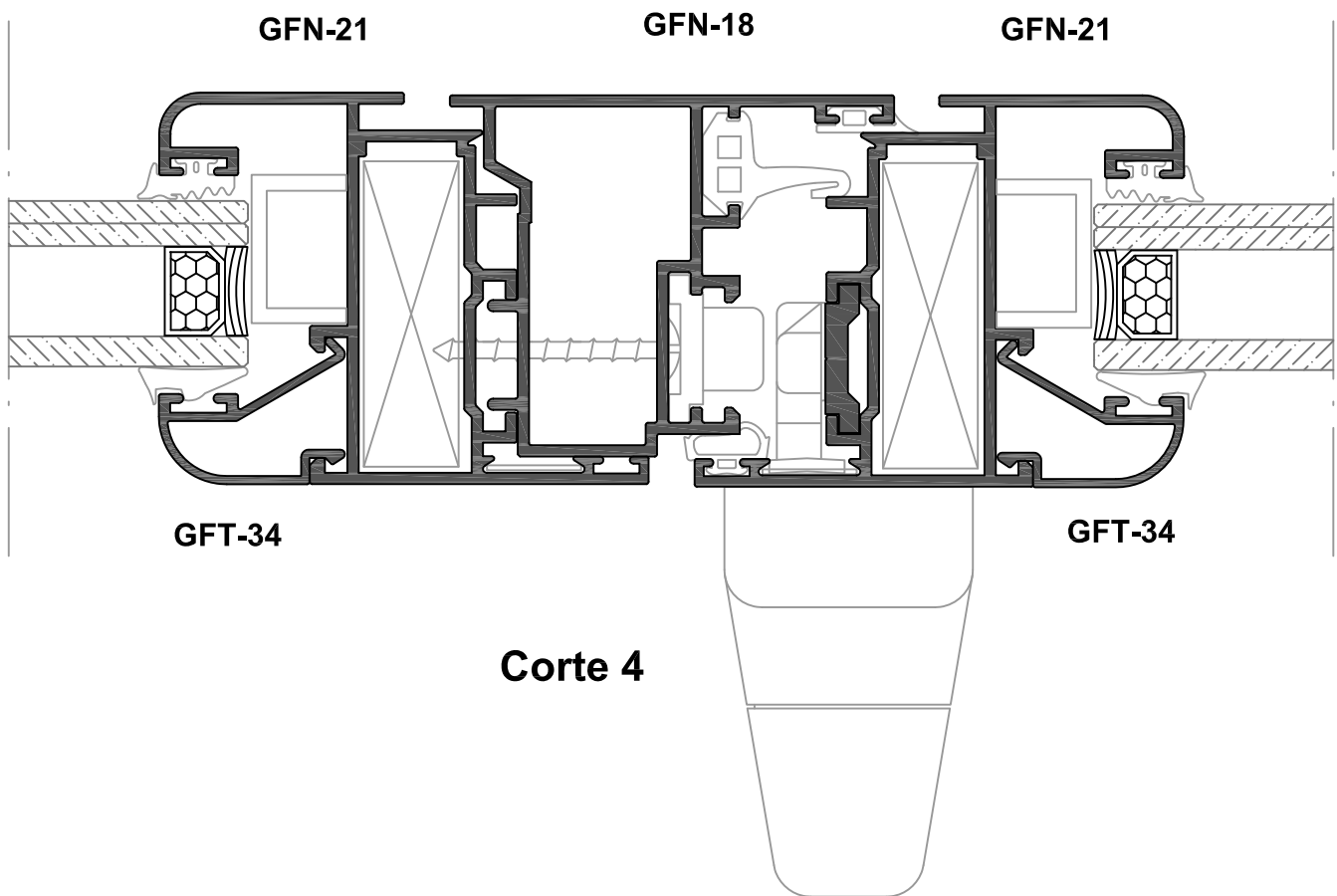
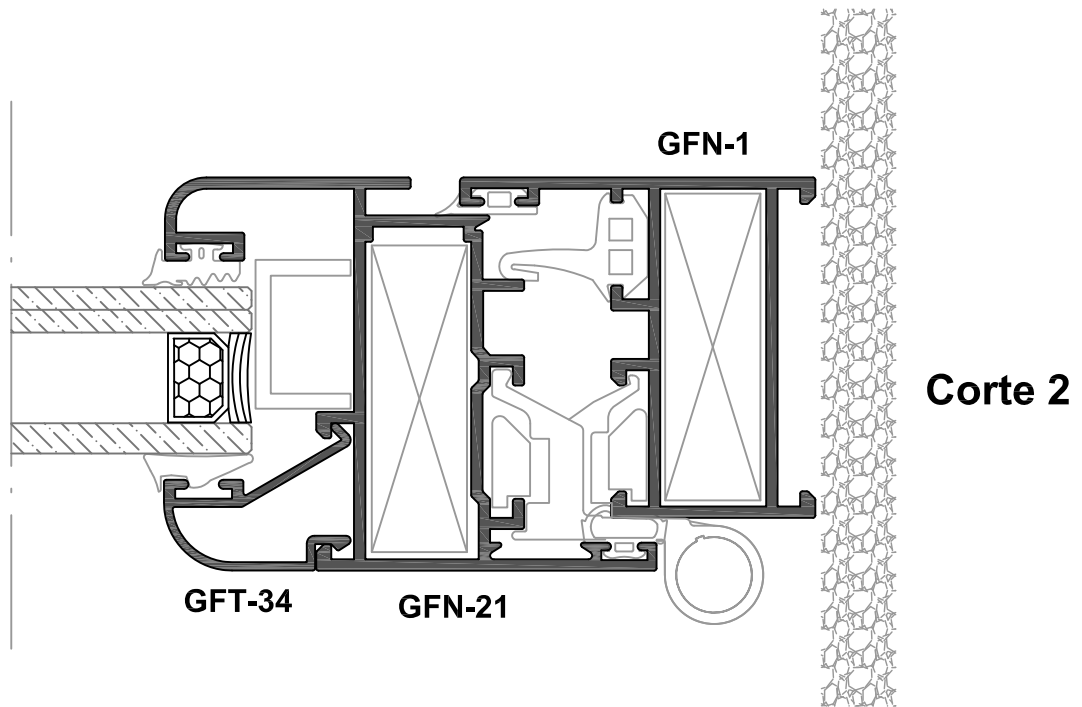

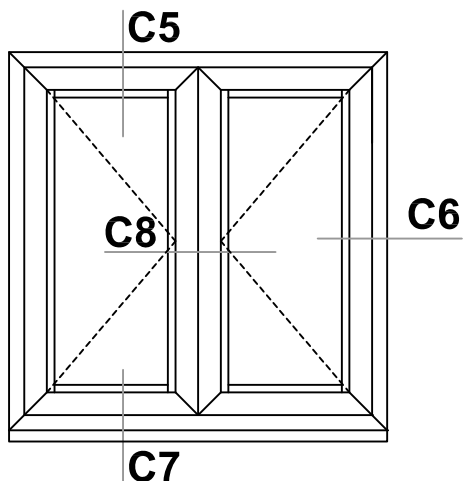

Ventana 2 hojas apertura exterior

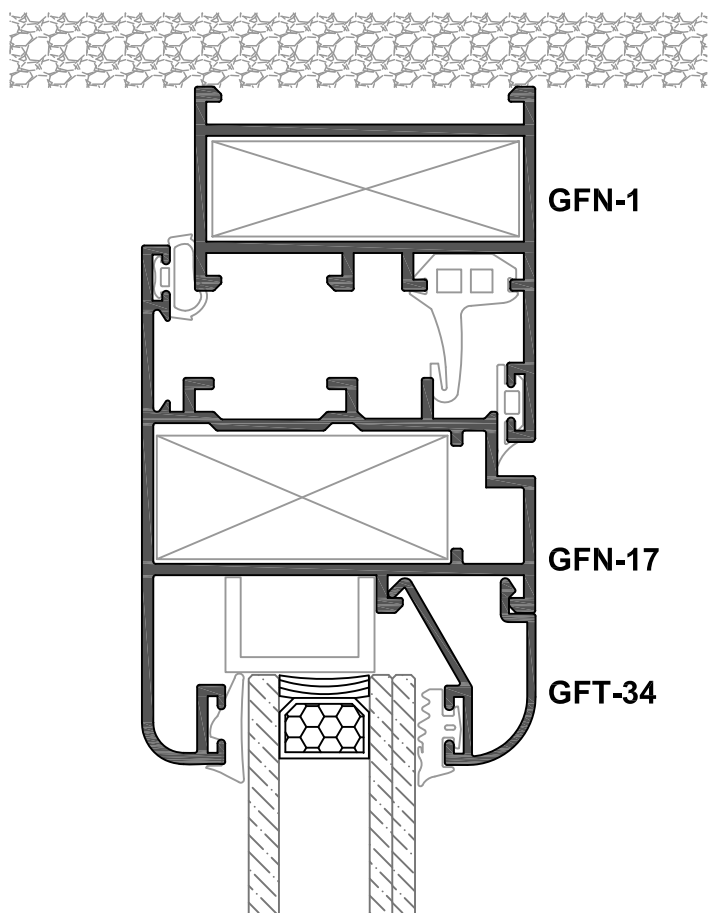

Corte 5

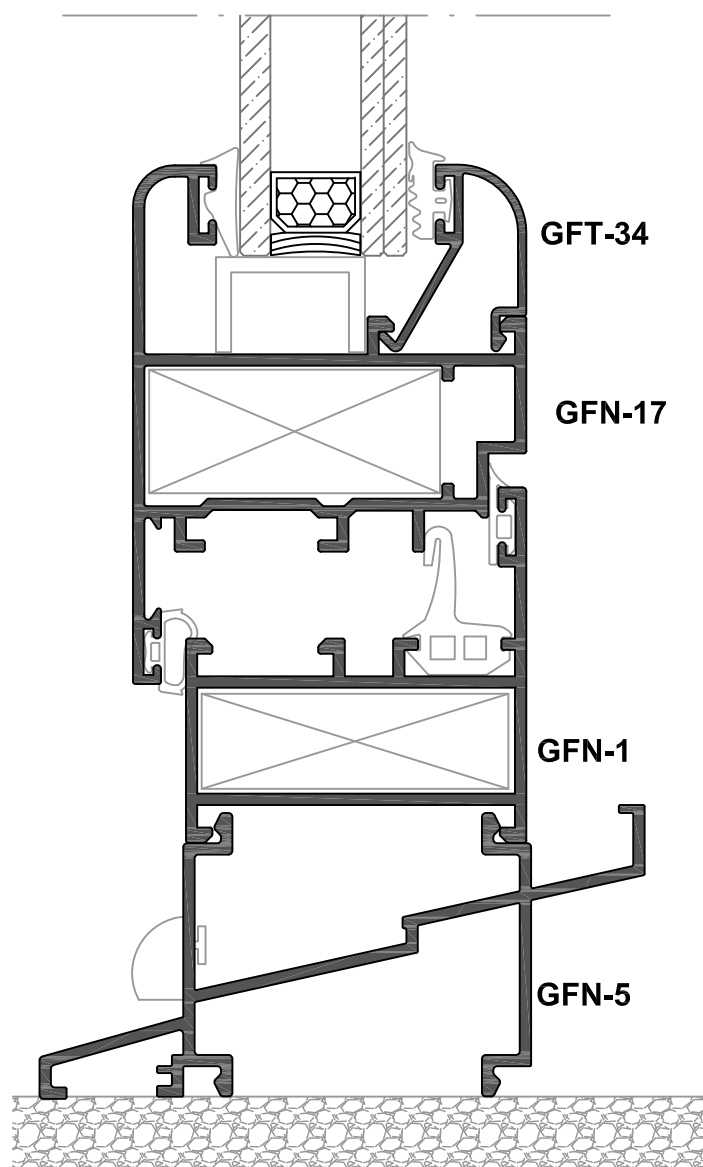

Corte 7

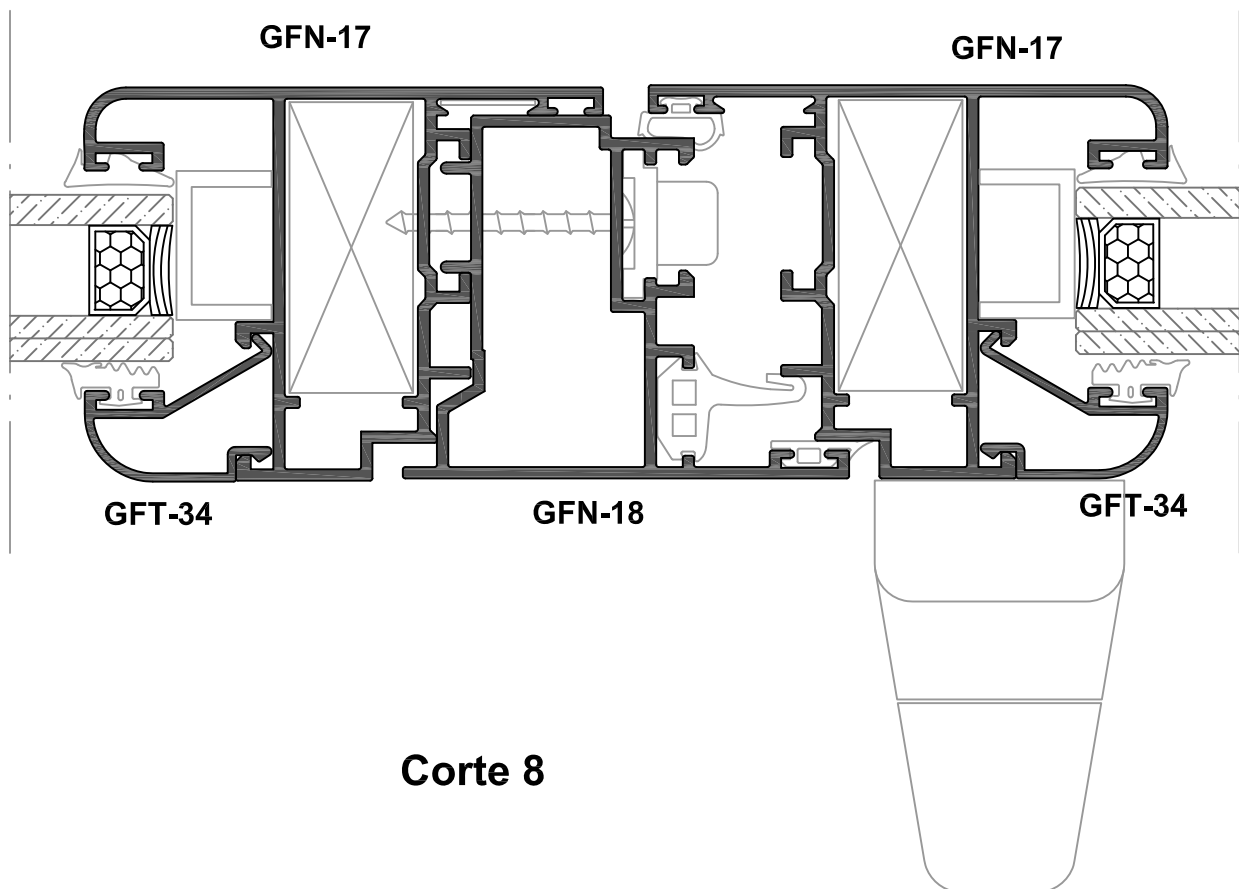
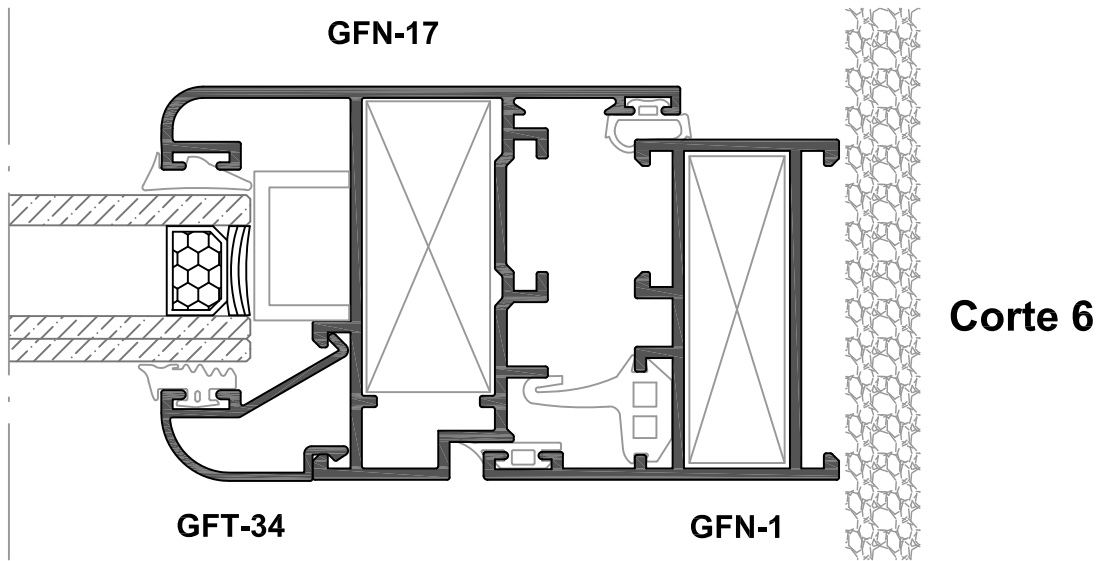

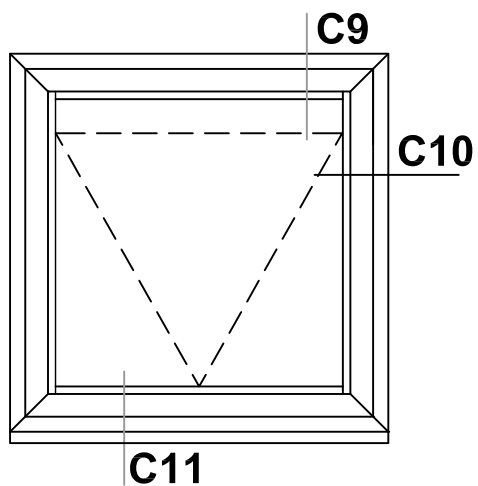

Ventana 1 hoja proyectante deslizante

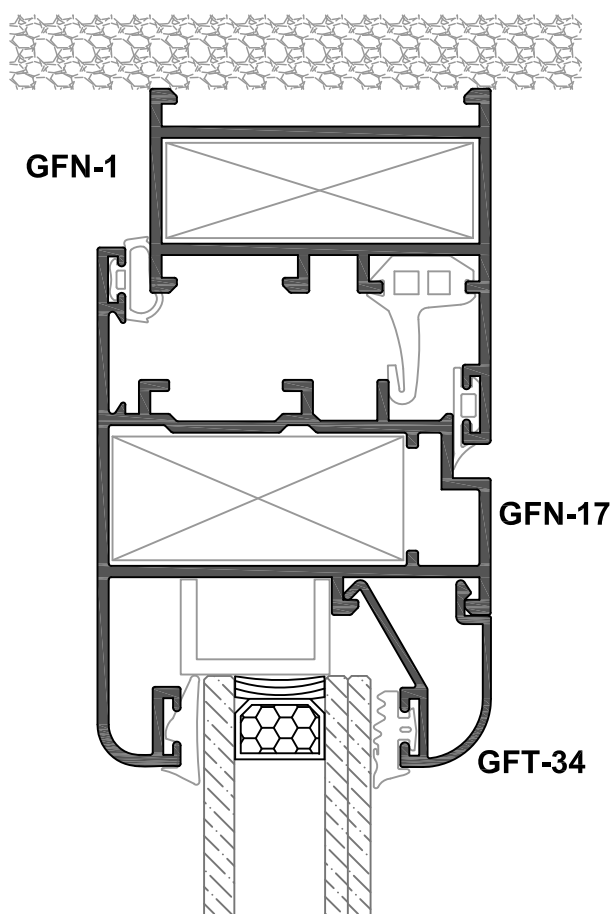

Corte 9

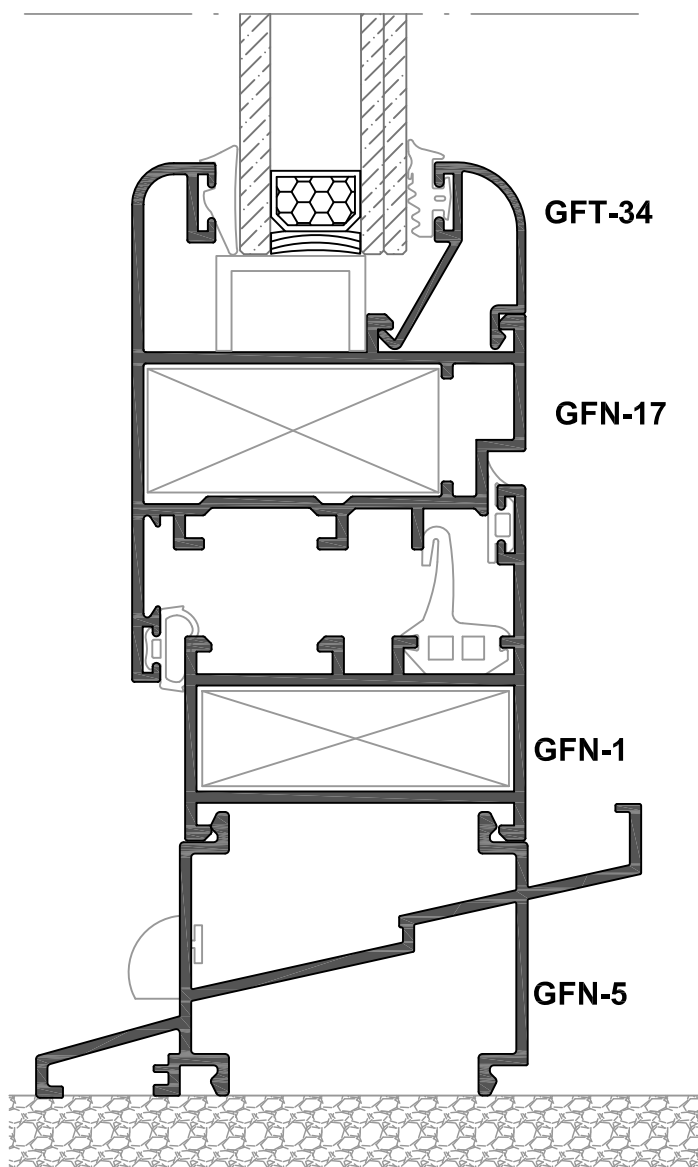

Corte 11

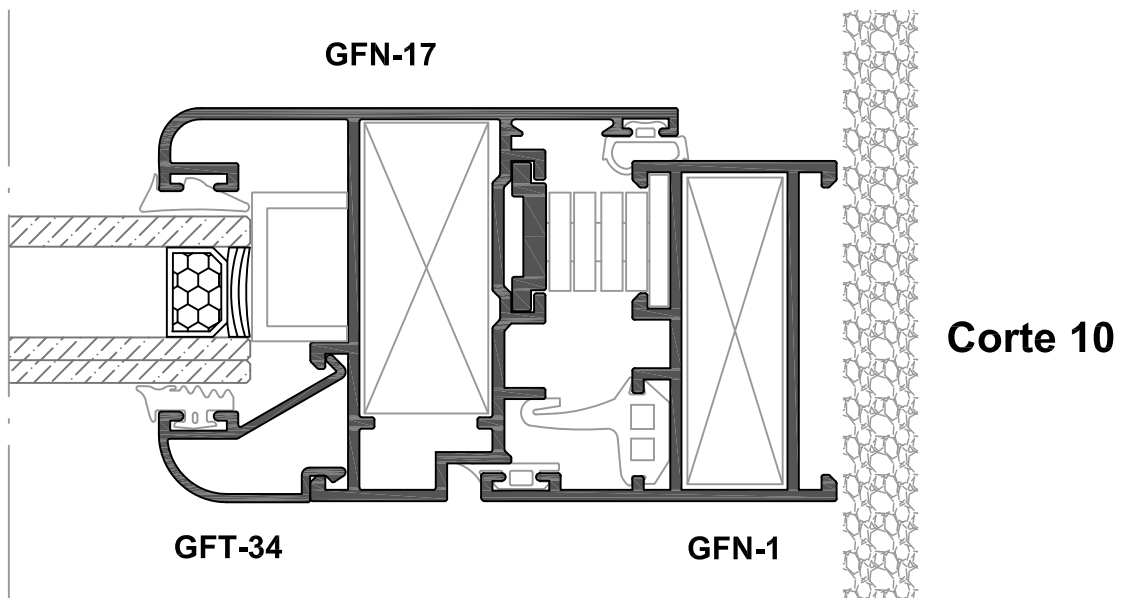

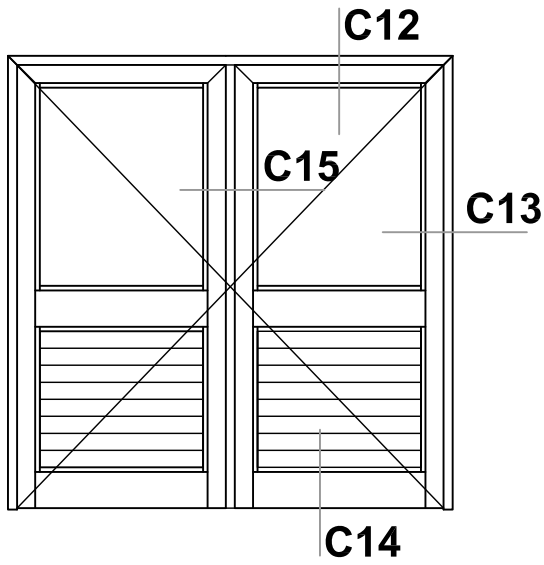

Puerta 2 hojas practicables

Corte 12

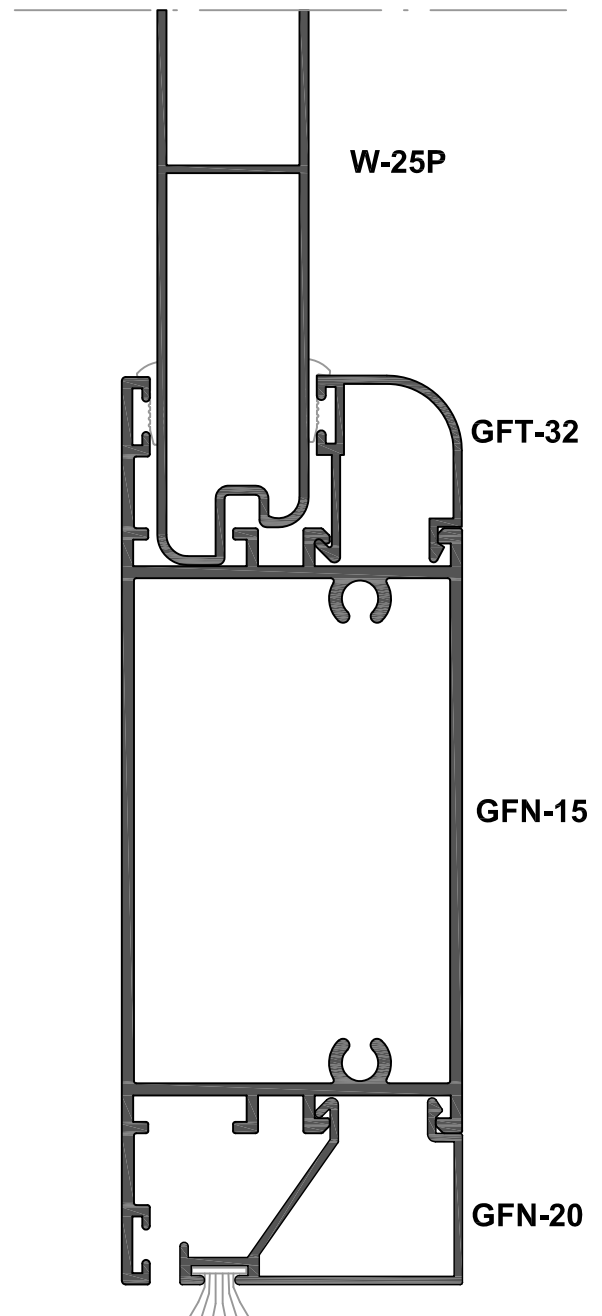
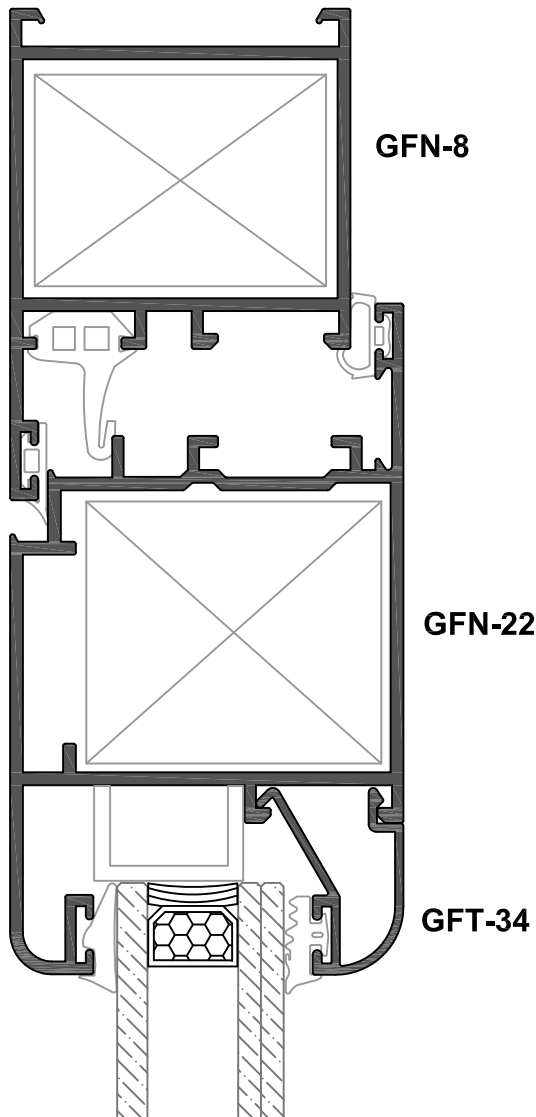
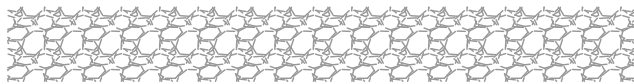

Corte 14

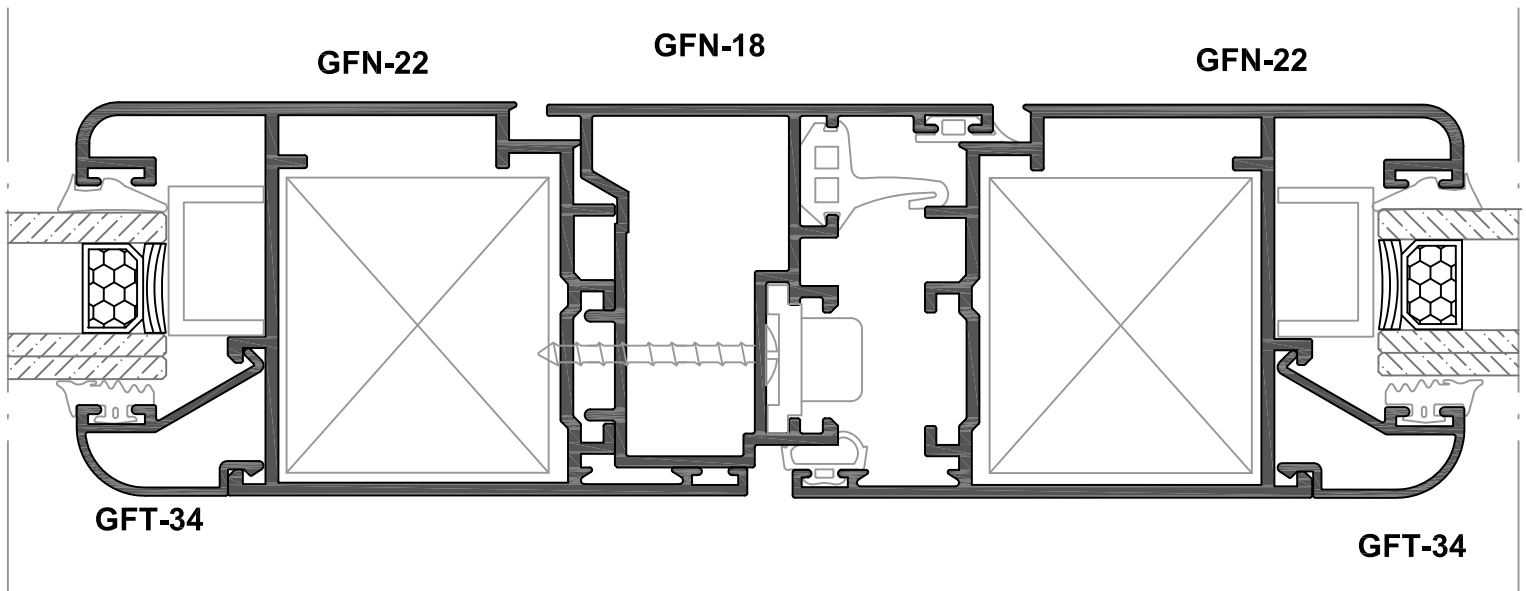
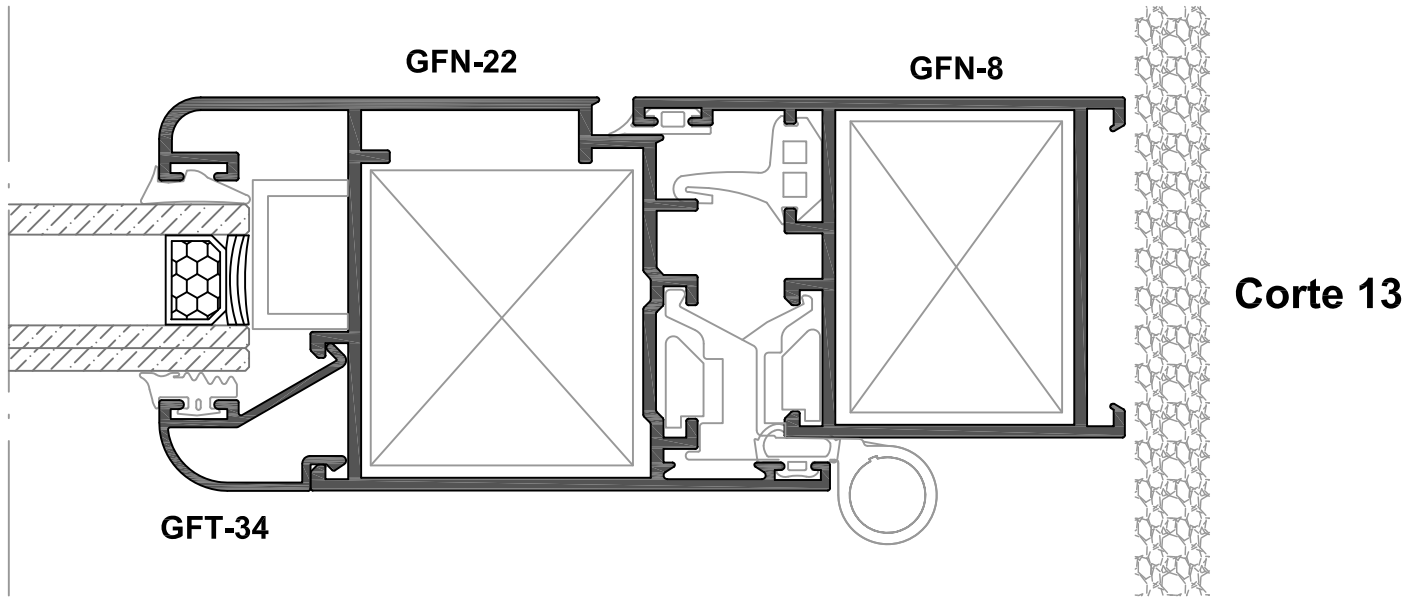

Corte 15

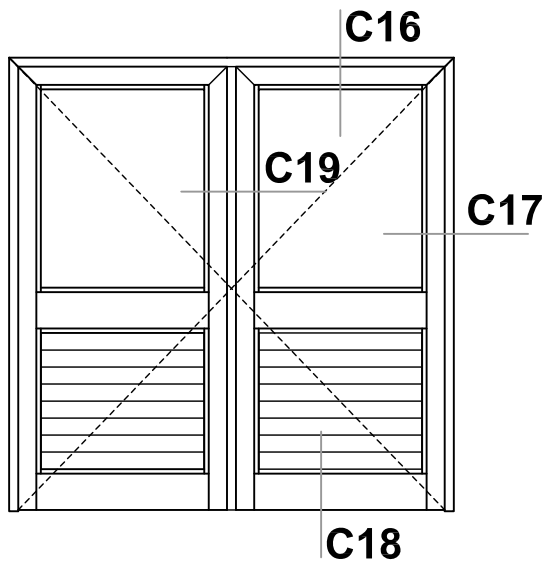

Puerta 2 hojas practicables apertura exterior

Corte 16

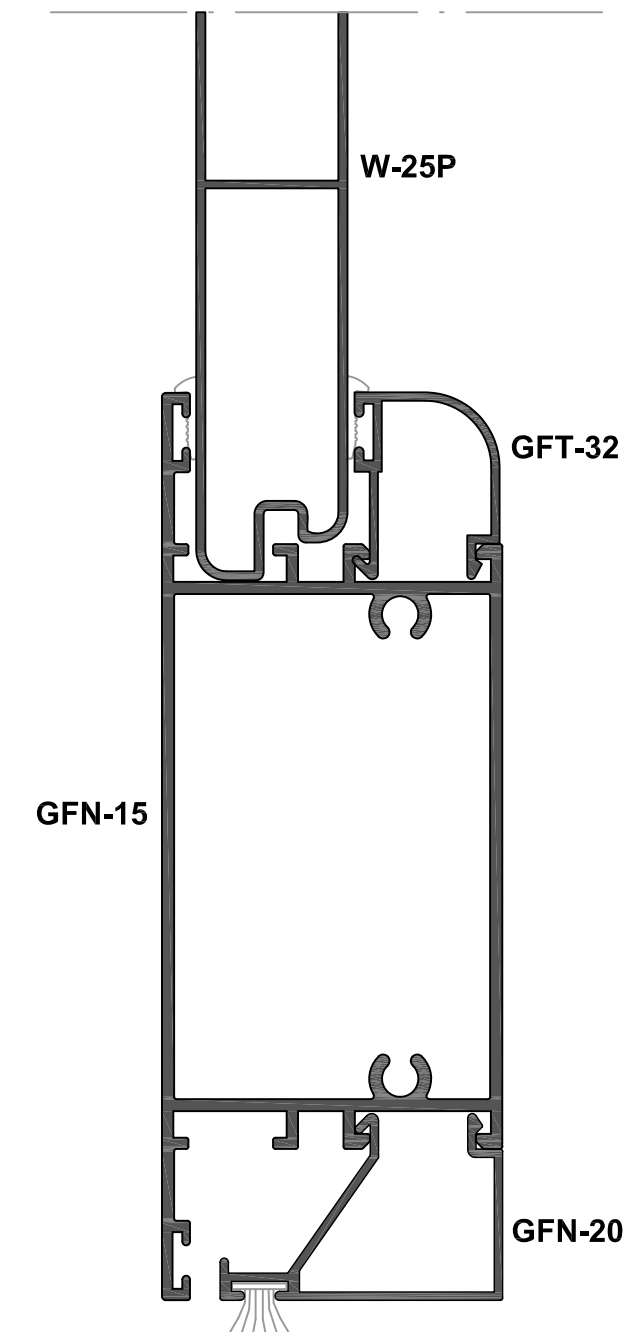
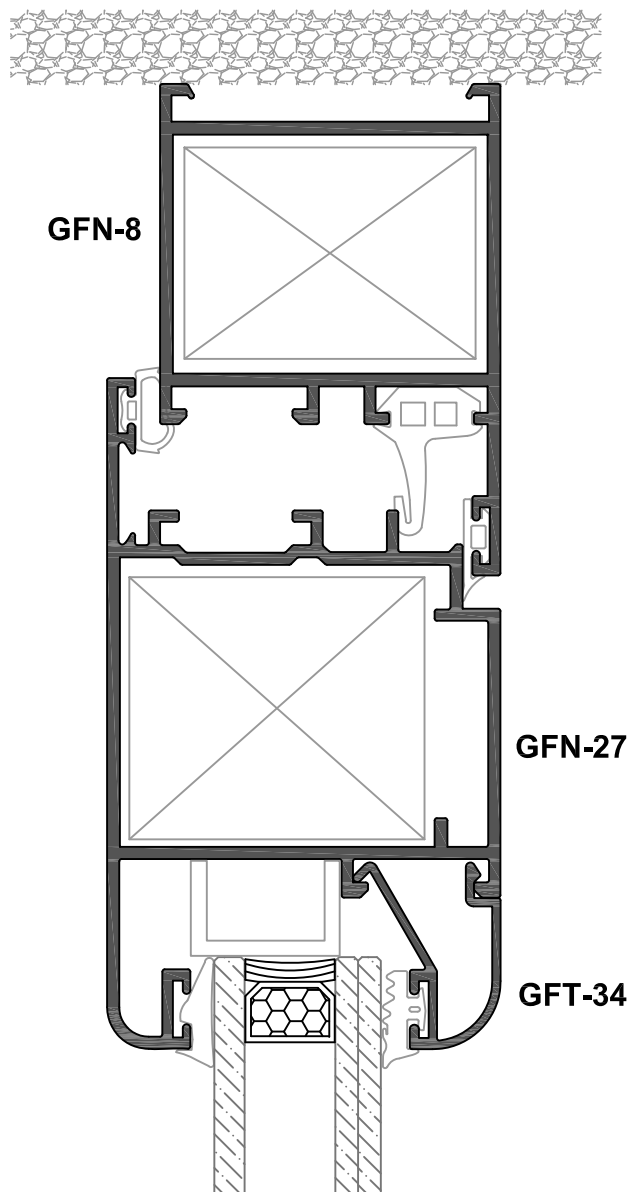

Corte 18

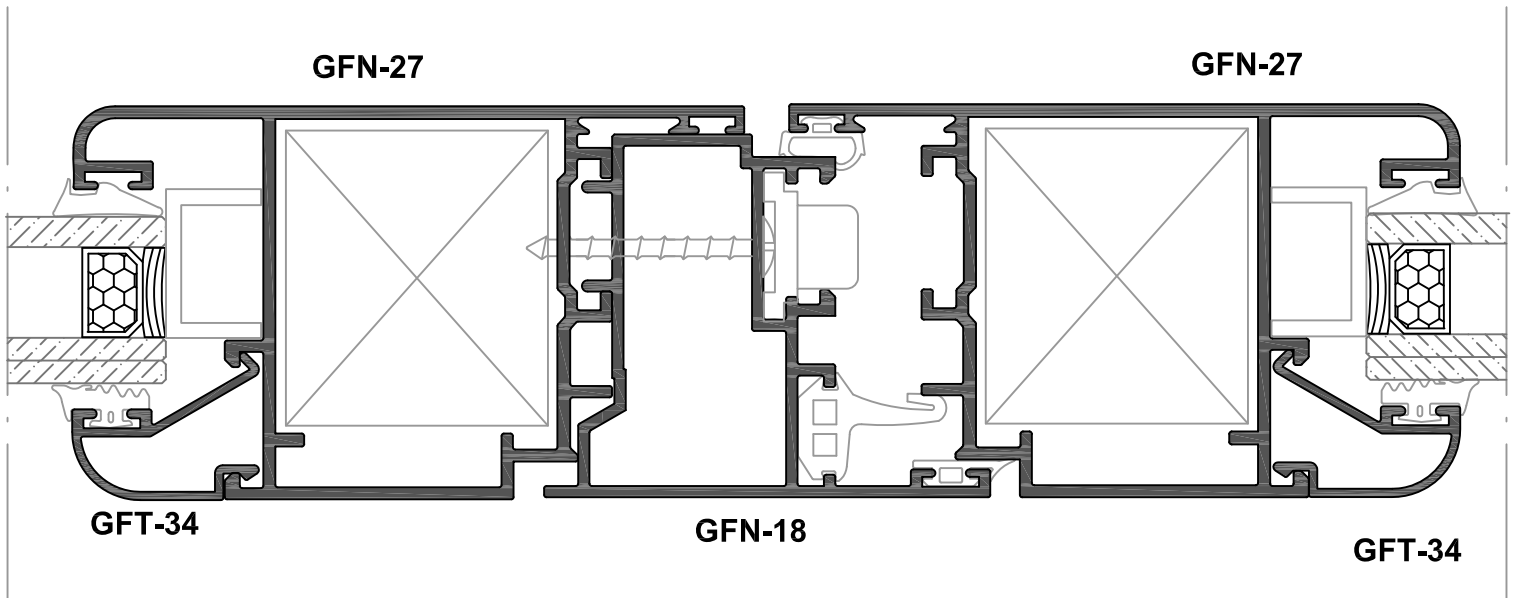
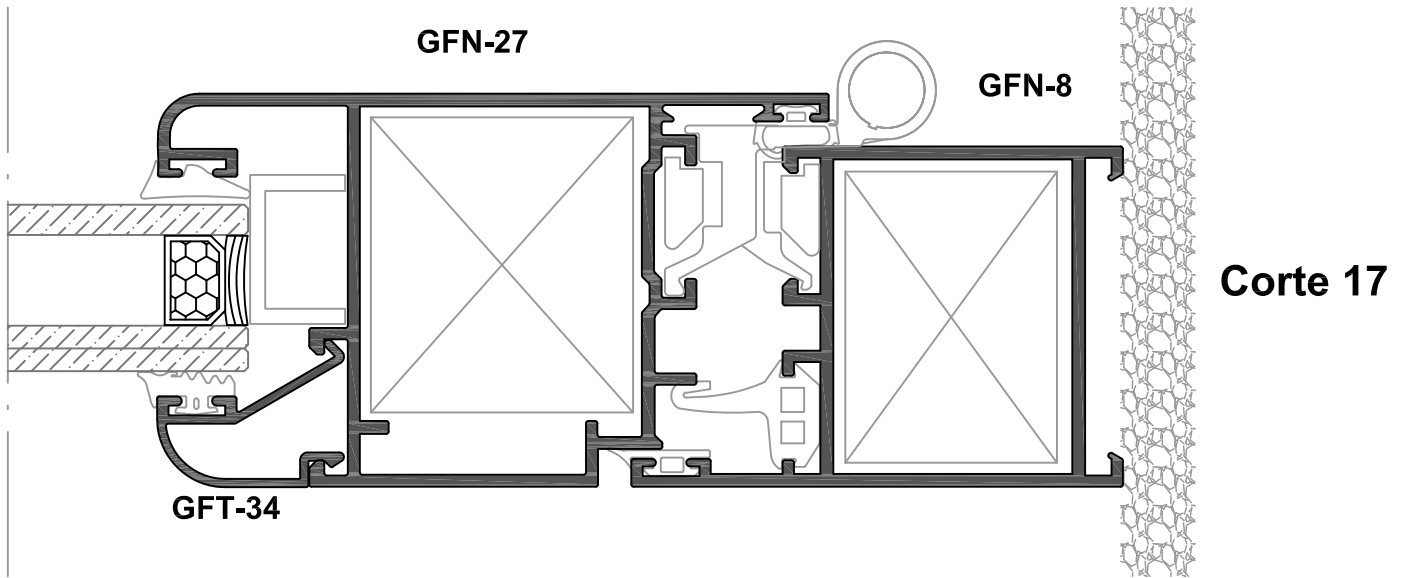

Corte 19

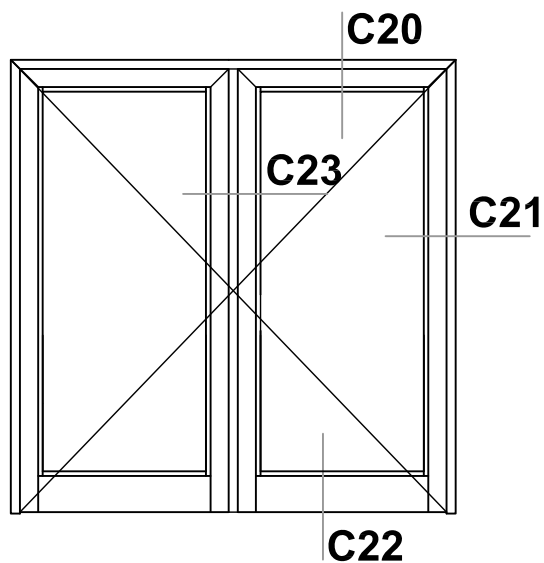

Puerta 2 hojas practicables apertura interior

Corte 20

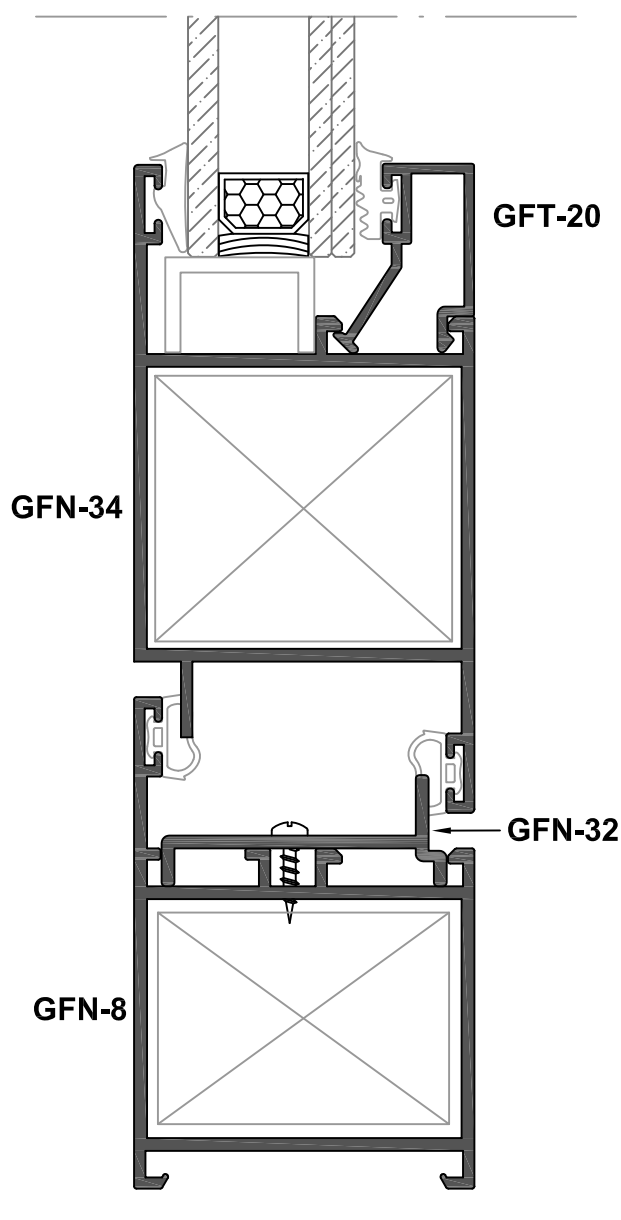
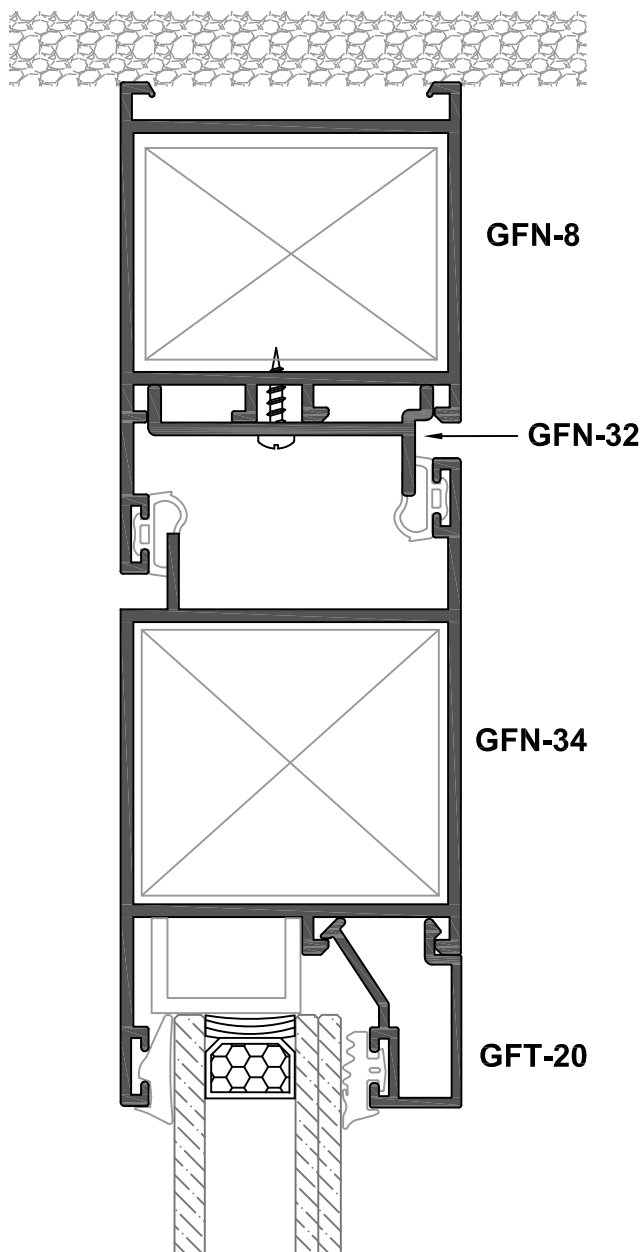

Corte 22

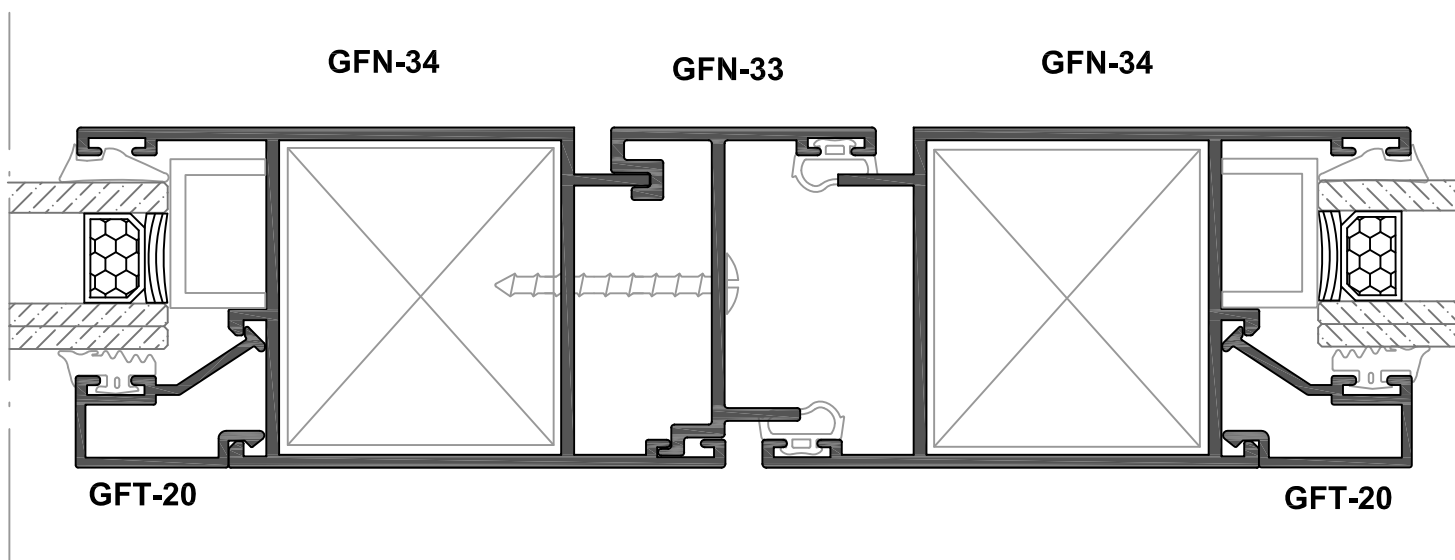
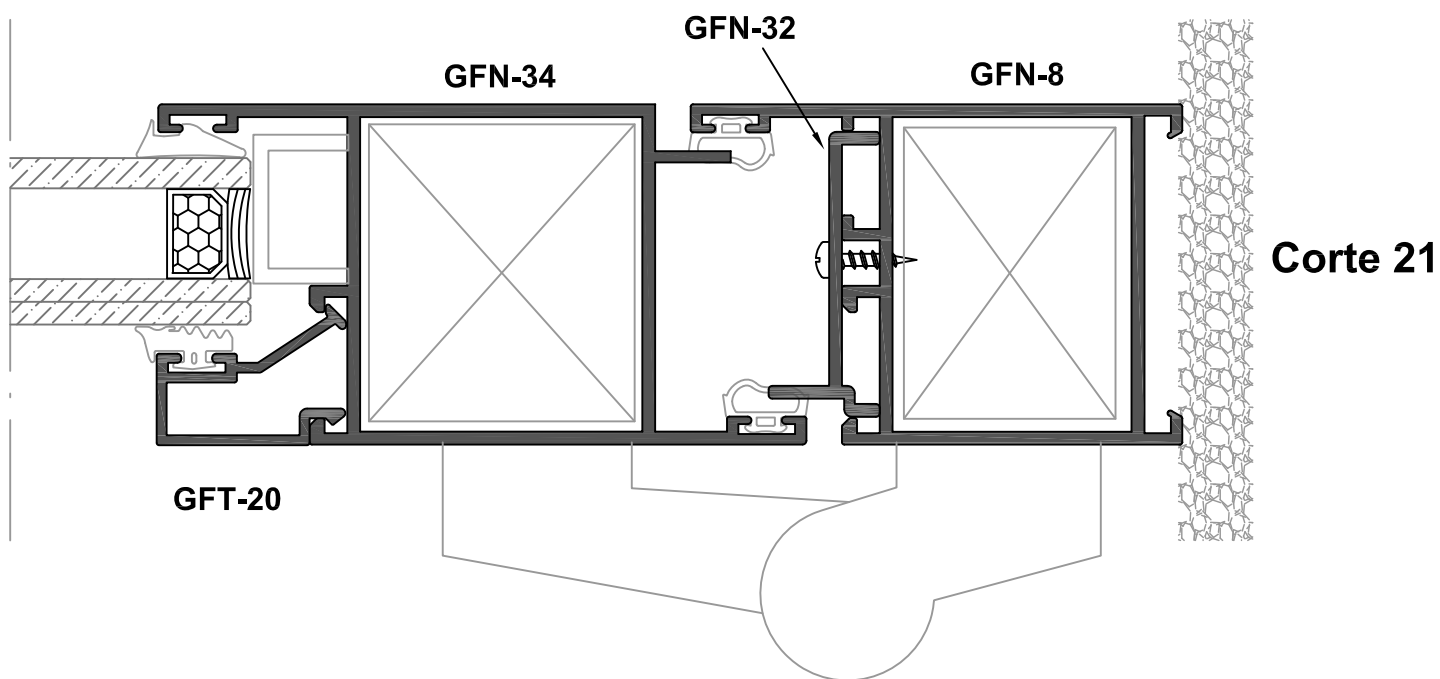

Corte 23

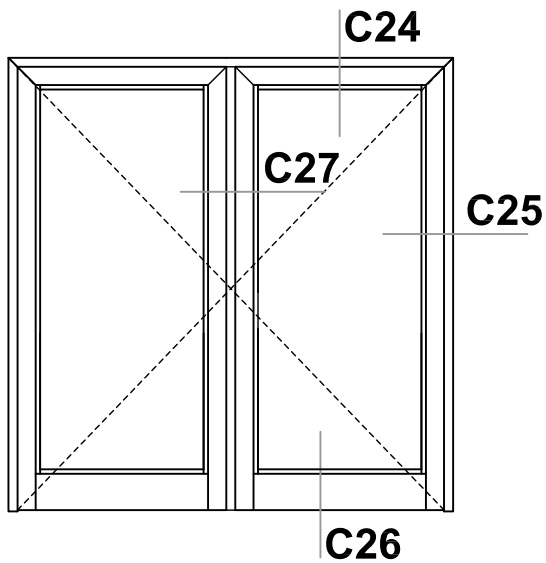

Puerta 2 hojas practicables apertura exterior

Corte 24

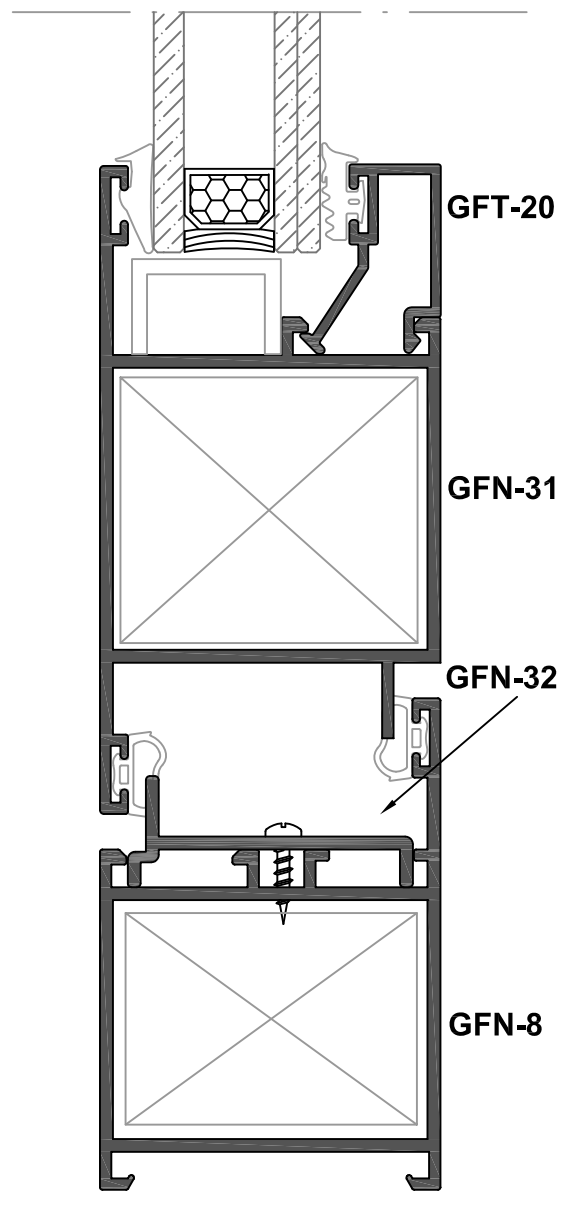
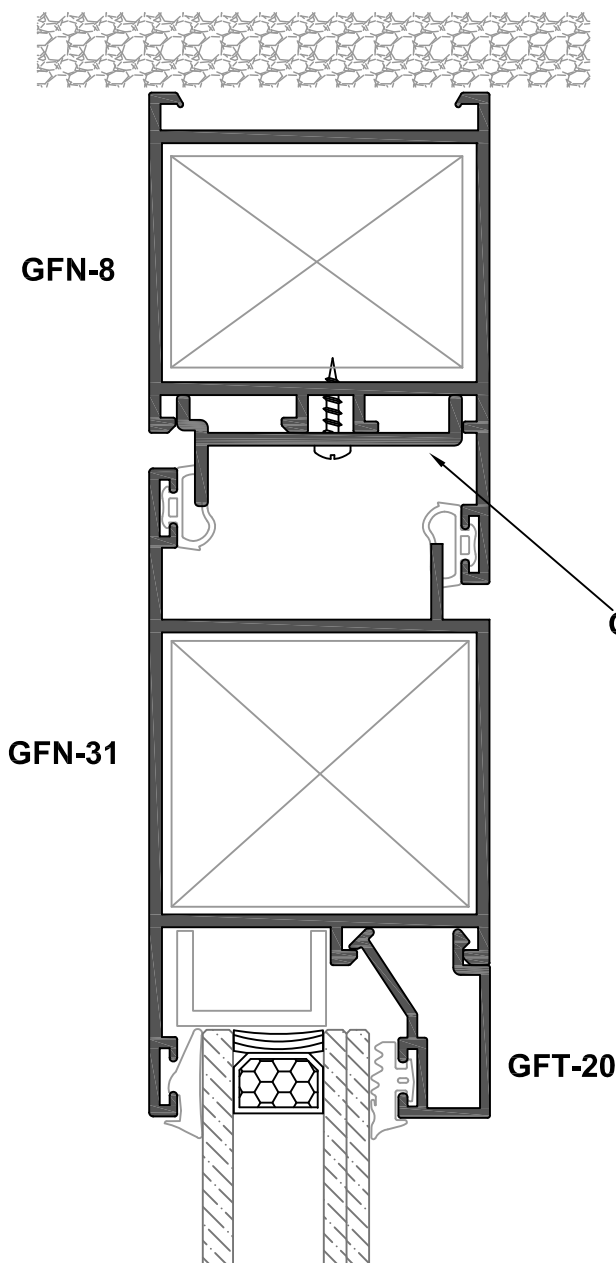

Corte 26

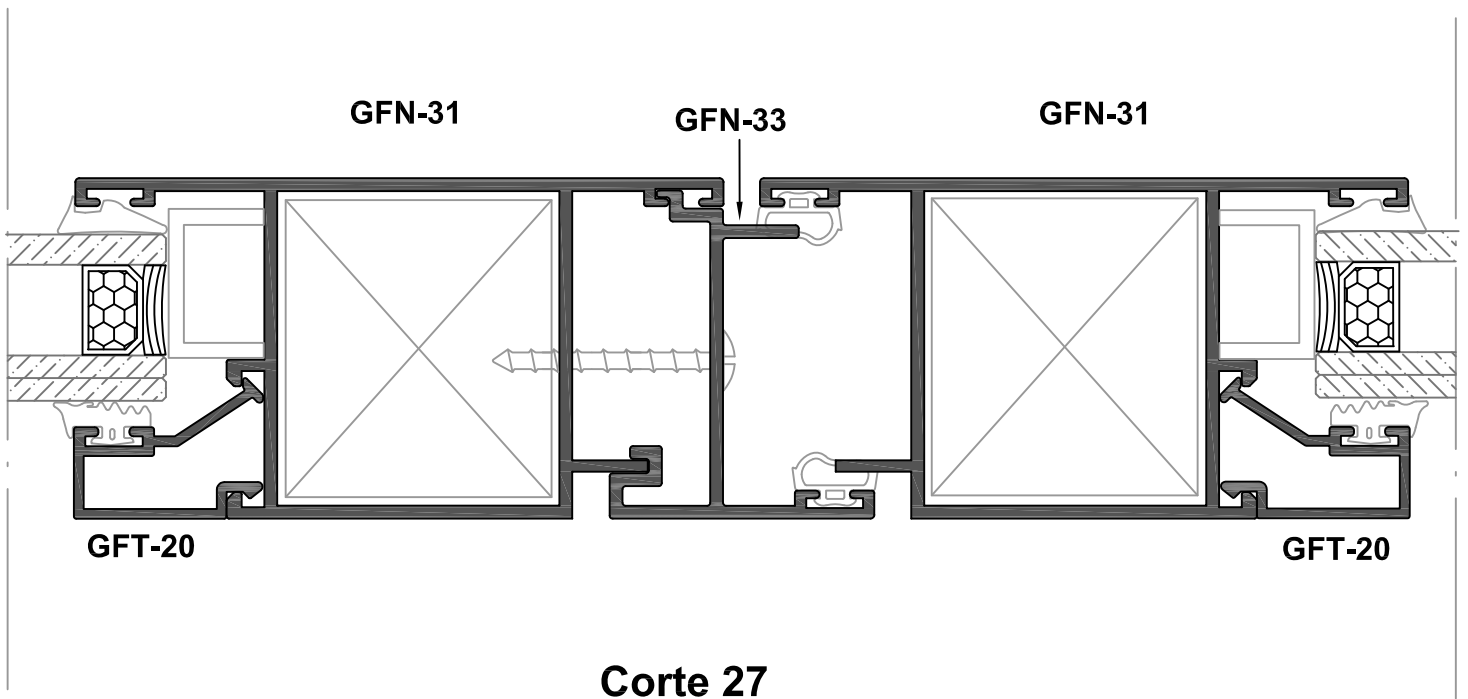
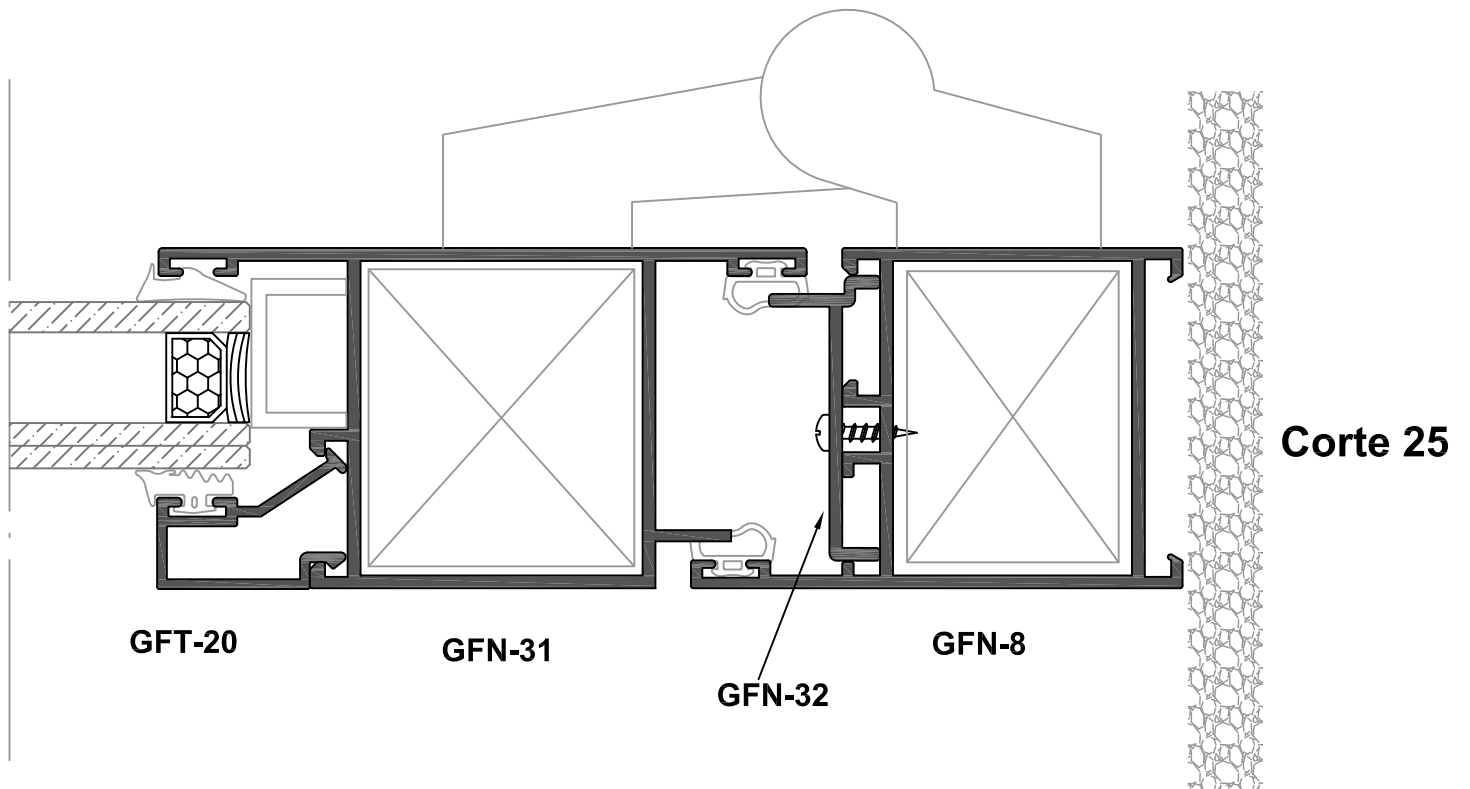

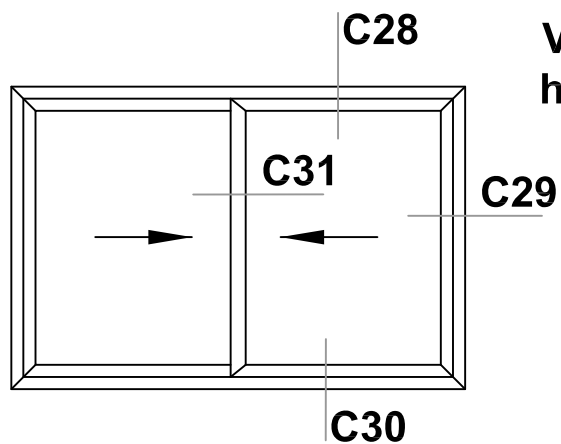

Ventana corredera perimetral 2 hojas

Corte 28

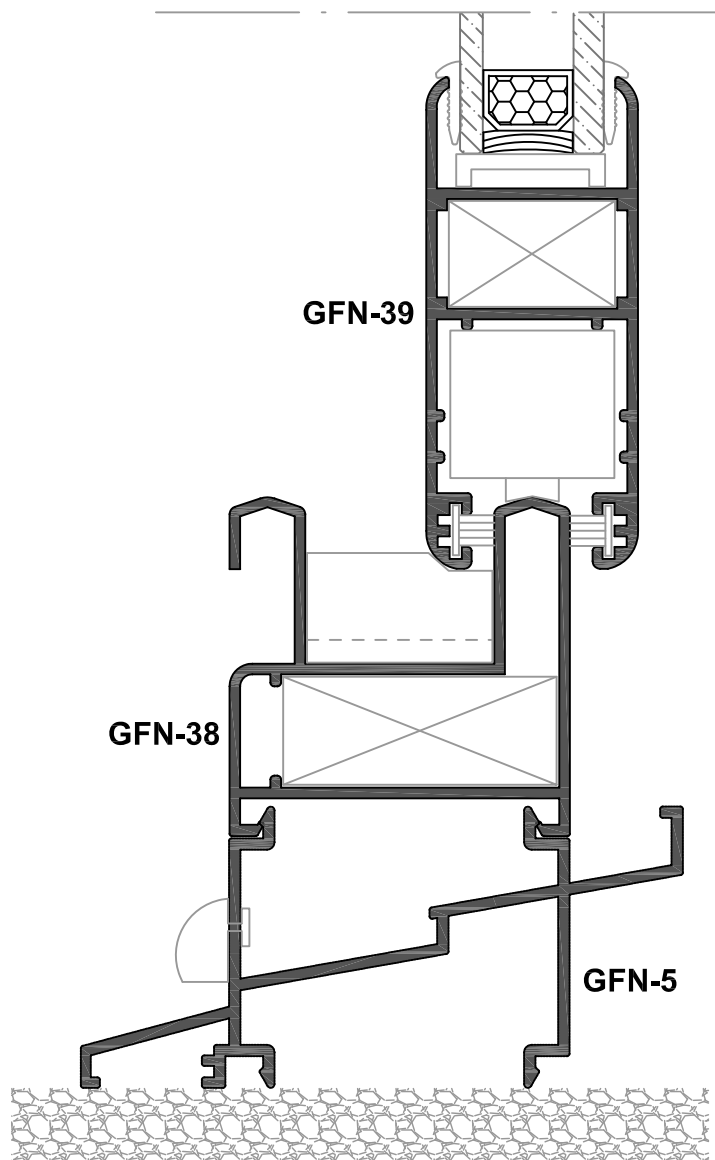
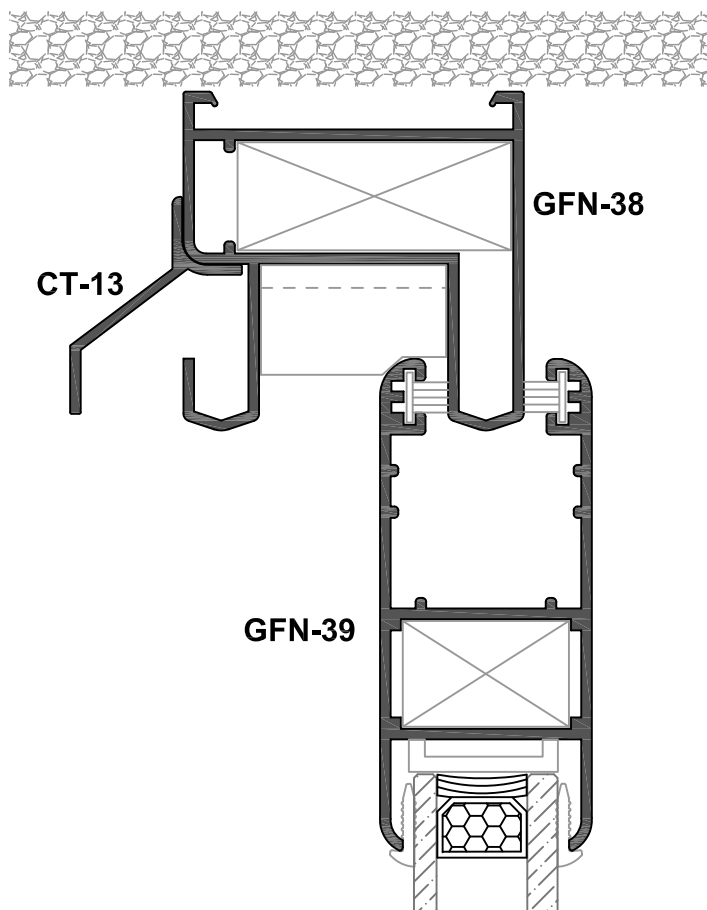

Corte 30

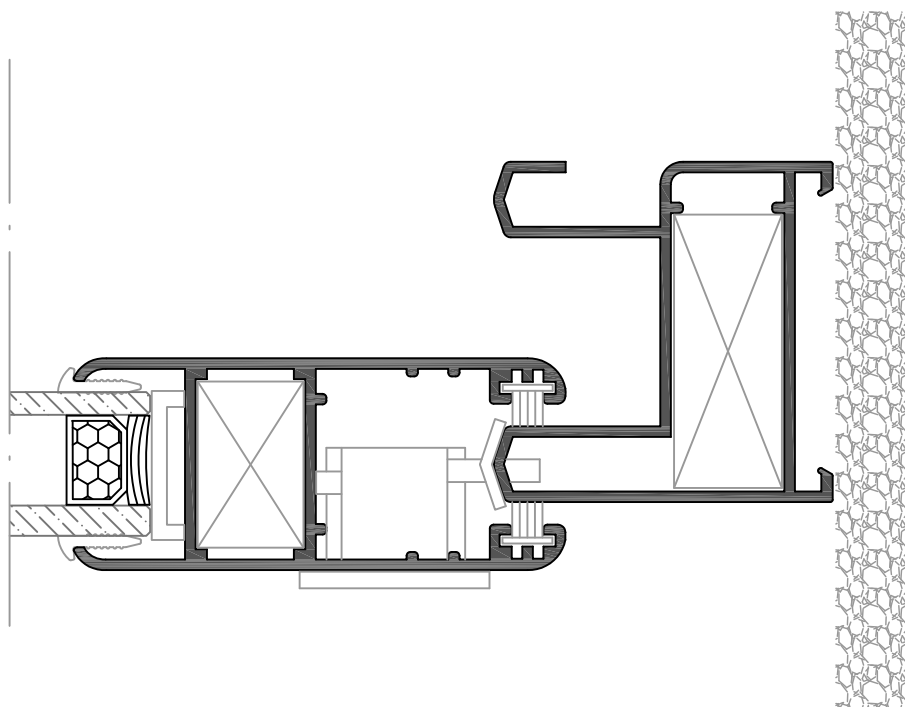

Corte 29

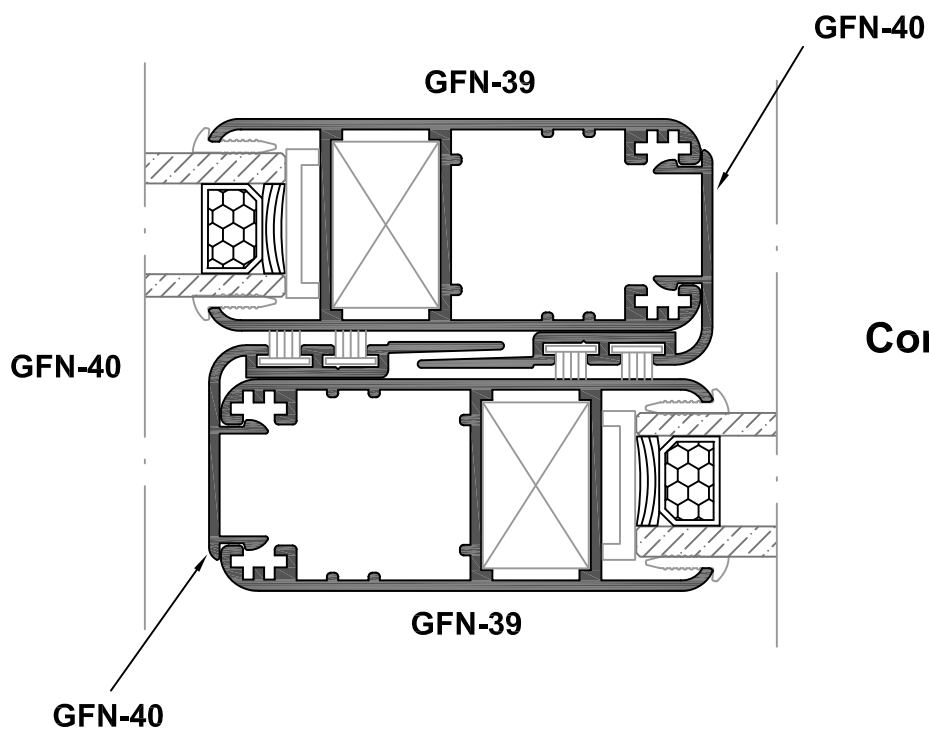

Corte 31

Alugal A Coruña

Crta. Nacional A Coruña-Santiago.
Sigras. A Coruña

Telf: 981 67 69 01
Fax: 981 61 31 36

Alugal Lugo

Estrada A Coruña. Bagueixo
Lugo

Telf: 982 21 47 49
Fax: 982 26 42 02

Alugal Santiago

Pol. Industrial Tambre. Via Diesel
Parcela R7. Santiago de Compostela.

Telf: 981 55 75 14
Fax: 981 51 97 99

Alugal León

Crta. León Zamora. Km.2
León

Telf: 987 21 47 12
Fax: 987 21 47 90



Alugal Vigo

Crta. de Vigo-Vincios. Km.8.
Gondomar. Pontevedra

Telf: 986 46 80 51
Fax: 986 46 80 26

Galimetal

Pol. Industrial de A Cañiza.
A Cañiza. Pontevedra.

Telf: 986 65 13 67
Fax: 986 65 23 95

Alugal Valladolid

Calle Estaño, Parcela 15.
Pol. San Cristobal. Valladolid

Telf: 983 39 66 30
Fax: 983 29 49 31

Alugal Ourense

Crta. de Ourense-Santiago. Km 545
Gusteí. Ourense

Telf: 988 20 42 11
Fax: 988 20 57 93

Alugal Oficinas

Crta. de Vigo-Vincios. Km.8.
Gondomar. Pontevedra

Telf: 986 46 83 30
Fax: 986 46 80 26

Alugal Toledo

Pol. Ind. San Sebastian.
C/ Herreros s/n. Madridejos. Toledo

Telf: 925 46 73 27
Fax: 925 46 73 22