

## - ÍNDICE -

A.- Descripción Técnica

B.- Relación perfiles

C.-Accesorios y juntas

D.- Perfiles a escala

F.- Hojas de corte

G.- Secciones tipo.

H.- Fabricación.

## Características técnicas

RT74 H.O. C16 - A1

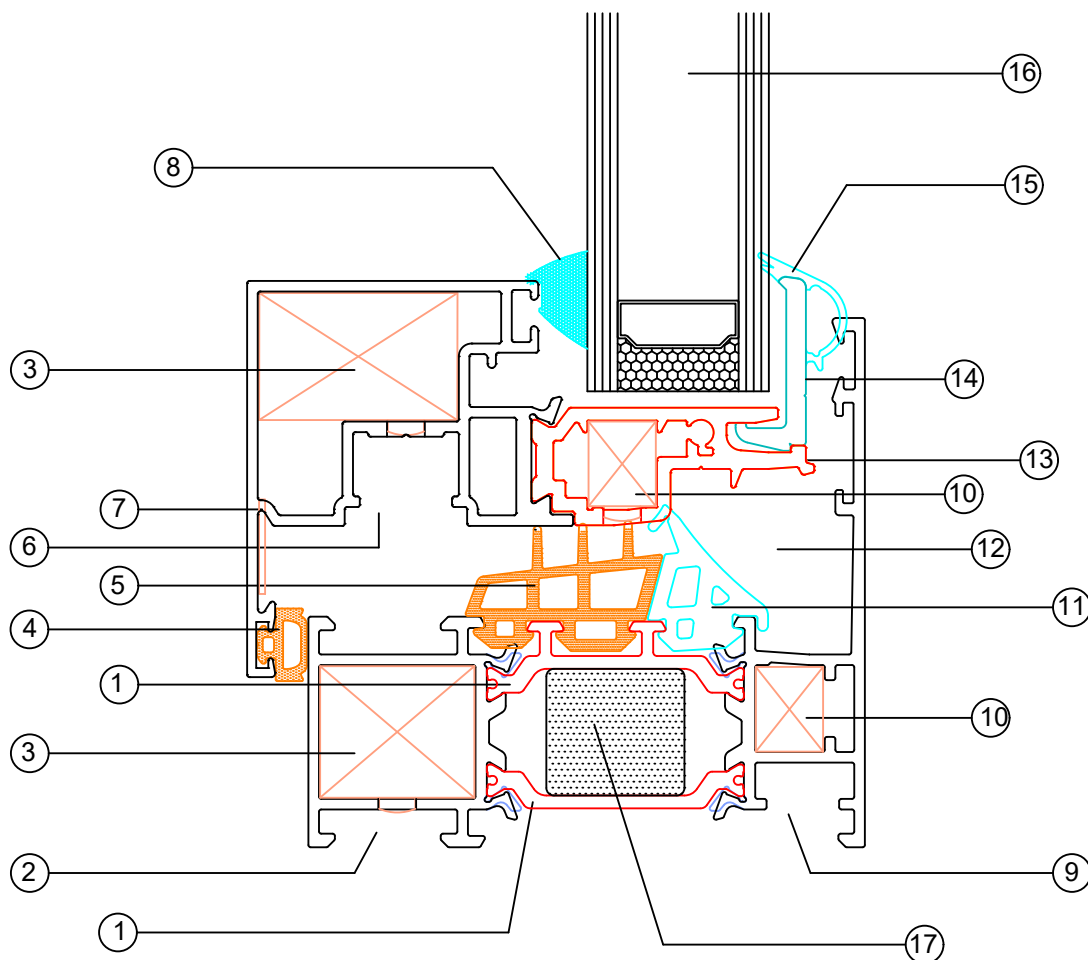

- |  |   |
|--|---|
| ① Rotura térmica con poliamidas de 34 mm             | ⑨ Posibilidad de vierteaguas exterior o condensador                 |
| ② Posibilidad recercado interior                     | ⑩ Escuadra exterior con tetón de resorte ó extrusión                |
| ③ Escuadra interior con tetón de resorte ó extrusión | ⑪ Junta central en EPDM   |
| ④ Junta interior espumosa                            | ⑫ Amplia cámara evacuación agua exterior                            |
| ⑤ Junta central espumosa para aislamiento térmico    | ⑬ Poliamida aislante exterior                                       |
| ⑥ Accesorios cámara europea                          | ⑭ Junquillo exterior en poliamida                                   |
| ⑦ Escuadra alineamiento en inox.                     | ⑮ Junta exterior EPDM acoplada a junquillo                          |
| ⑧ Sellado con junta EPDM                             | ⑯ Amplia posibilidad de acristalamiento según hoja y junta interior |
|  | ⑰ Relleno de aislante térmico                                       |

## Características técnicas

RT74 H.O. C16 - A2

**Sistema:** Batiente cámara europea con rotura de puente térmico, mediante perfiles continuos de poliamida de 34 mm de largo en marco y poliamida especial en hoja.

**Perfiles:** Aleación de aluminio EN AW-6060/3 T5

**Aperturas:** Interior, oscilobatiente

**Dimensiones:** Marco fijo 73,6 mm. Hoja móvil 73,9 mm

**Cortes:** A inglete

**Uniones:** Escuadras interiores y exteriores respecto a la rotura térmica, en fundición de aluminio a presión con tetón redondo con resorte ó de extrusión de aluminio.

**Estanqueidad:** Triple junta de EPDM, con suplemento en espuma celular para mejorar el aislamiento térmico.

**Junquillos en marco:** Recto con cortes a 90°

**Junquillos en hoja:** Exterior, especial en poliamida, con junta EPDM acoplada

**Acristalamiento:** de 24 a 34 mm, según perfil hoja y juna acristalamiento interior

### CLASIFICACIONES:

Permeabilidad al aire: Clase 4 (UNE-EN 12207)









Estanqueidad al agua: E2100 (UNE-EN 12208)

Resistencia al viento: Clase CE2400 (UNE-EN 12210)

} Ensayo sobre ventana de 1.230x1480 mm

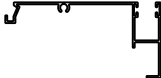

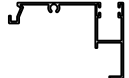
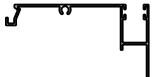

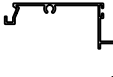

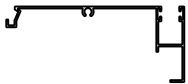
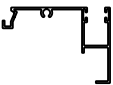
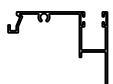

## Relación de perfiles

RT74 H.O. C16 - B1

Ref.	Diseño	Descripción	Pag.
1247/5		Alargadera 90	D10
1247/7		Alargadera 120	D10
1247/8		Alargadera 150	D10
1247/9		Alargadera 180	D10
7-05		Guía 104 mm	D15
7-06		Guía 60 mm	D15
7-08		Guía 75 mm	D15
7-09		Guía 95 mm	D15
7-10		Guía 90 mm	D15
7-11		Guía 80 mm	D15

## Relación de perfiles

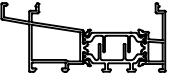
RT74 H.O. C16 - B2

Ref.	Diseño	Descripción	Pag.
7-12		Guía 120 mm	D15
7-13		Guía 70 mm	D15
7-14		Guía 70 mm	D15
7-15V		Guía 45 mm	D15
7-16V		Guía 45 mm	D15
74-05		Condensación con alargadera 25 mm	D7
74-06		Condensación con alargadera 65 mm	D7
74-07		Unión marcos	D20
74-24		Condensación	D7
74-28		Suplemento marcos	D20

## Relación de perfiles

RT74 H.O. C16 - B3

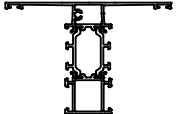
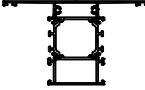
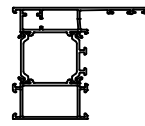
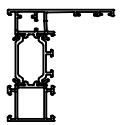
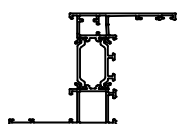
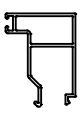
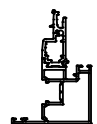
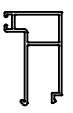
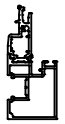
Ref.	Diseño	Descripción	Pag.
74-73		Condensador	D8
74004		Travesaño 110 mm	D2
74013		Travesaño 128 mm	D3
74014		Marco puerta	D1
74018		Marco ventana	D1
74018L		Marco ventana con solape	D2
74020		Junquillo para fijos vidrios 24-26-28	D6
74021		Hoja ventana RPT vidrios 24-26-28	D4
74023		Junquillo para fijos vidrios 30-32-34	D6
74074		Hoja ventana RPT sin ala vidrios 24-26-28	D4





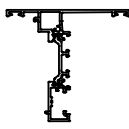
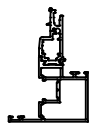
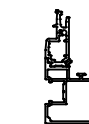
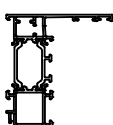
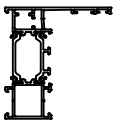
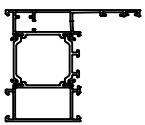
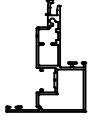
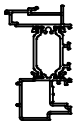
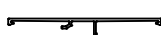
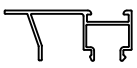

## Relación de perfiles

RT74 H.O. C16 - B4

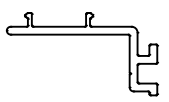
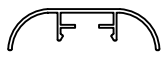
Ref.	Diseño	Descripción	Pag.
74075		Inversor reducido	D3
74076		Hoja ventana RPT vidrios 30-32-34	D4
74077		Hoja ventana RPT sin ala vidrios 30-32-34	D4
74081		Marco ventana	D2
74088		Marco ventana	D1
74089		Marco puerta	D1
74102		Hoja ventana vidrios 30-32-34	D5
74103		Inversor	D5
74104		Tapeta inversor 74103	D5
GALI-1148		Perfil acople junquillos	D6

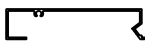
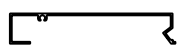
## Relación de perfiles







RT74 H.O. C16 - B5

Ref.	Diseño	Descripción	Pag.
GALI-1136		Alargadera 120 mm	D9
GALI-1006		Perfil grapa	D13
GALI-1007		Guarnición grapa	D13
GALI-1022		Soporte compás	D3
GALI-1063		Recercado 100 mm	D11
GALI-1064		Recercado 120 mm	D11
GALI-1078		Guarnición grapa	D13
GALI-1085M		Solape clip	D14
GALI-1086M		Solape para guías	D14
GALI-1106		Alargadera 82 mm	D9





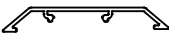
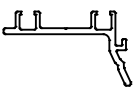
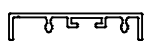

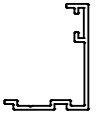
## Relación de perfiles

RT74 H.O. C16 - B6

Ref.	Diseño	Descripción	Pag.
GALI-1115V		Solape marco 30 mm	D14
GALI-1116V		Solape guías 30 mm	D14
GALI-1117V		Solape marco 45 mm	D14
GALI-1118V		Solape para guía 45 mm	D14
GALI-1134		Guarnición grapa	D13
GALI-1143		Perfil grapa para solape	D13
GALI-1144		Solape clip grapa 1143	D13
GALI-1135		Perfil unión oculta	D13
GALI-1145		Perfil unión vista	D13
GALI-1140		Solape 35 mm	D14

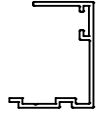
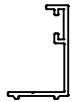

## Relación de perfiles

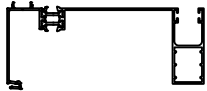
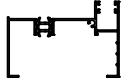
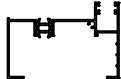
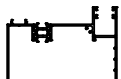
RT74 H.O. C16 - B7

Ref.	Diseño	Descripción	Pag.
GALI-1141		Solape 35x20 mm	D14
GALI-1142		Solape 30 mm	D14
GALI-1119V		Alargadera 100 mm	D9
GALI-1120V		Solape compacto	D17
GFT-39		Adaptador pletina cierre	D3
GFT-40-41V		Guía persiana 120 mm	D17
PT-33V		Guía persiana 138 mm	D17
PT-50		Guía persiana 100 mm	D16
PT-50M		Guía persiana 100 mm	D16
PT-50V		Guía persiana 100 mm	D17



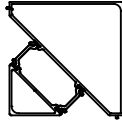
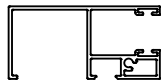
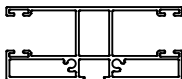
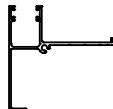
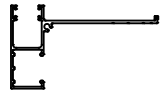

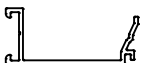
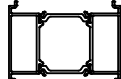
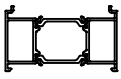
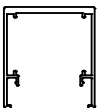

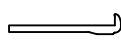

## Relación de perfiles

RT74 H.O. C16 - B8

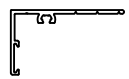
Ref.	Diseño	Descripción	Pag.
RTA72-08		Esquinero 90°	D20
GALI-1132		Guia embutida	D18
GALI-1133		Guia doble embutida	D18
7-20		Guia persiana corta	D19
7-21		Guia persiana larga	D19
GALI-1138		Recogedor persiana interior	D19
GALI-1139		Recogedor persiana interior ensarada	D19
74-30		Suplemento marcos 50 mm	D20
74-29		Suplemento marcos 40 mm	D20
GALI-1146		Perfil de refuerzo	D21

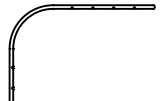

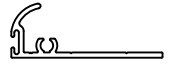

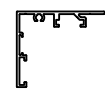
## Relación de perfiles

RT74 H.O. C16 - B9

Ref.	Diseño	Descripción	Pag.
GALI-1147		Calzo hojas	D3
SY-01		Solape clip 30 mm	D14
SY-11		Perfil remate 52x30 mm	D11
SY-13		Perfil remate 70x30 mm	D11
SY-17		Perfil remate 70x50	D12
SY-20		Perfil remate 120 mm	D9
SY-21		Perfil remate 50 mm	D12
SY-22		Perfil remate 126 mm	D11
SY-23		Perfil remate 70x50	D12
SY-24		Perfil remate 58x50	D12

## Relación de perfiles

RT74 H.O. C16 - B10

Ref.	Diseño	Descripción	Pag.
SY-25		Perfil remate 46x50	D12
SY-26		Acople clip	D14
SY-30		Perfil remate 111 mm	D9
VR05		Clipaje perfil de refuerzo	D21

## Relación de accesorios

RT74 H.O. C16 - C1

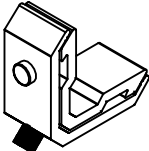
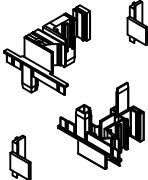
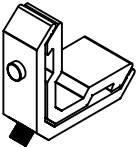
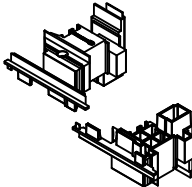
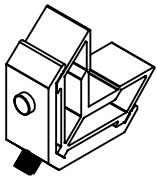
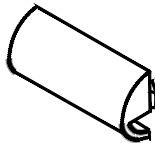
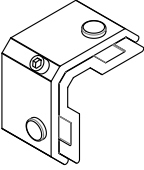
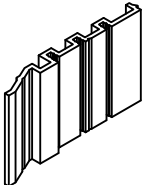
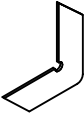
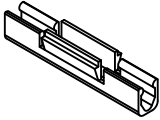
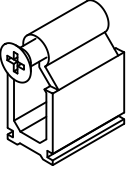
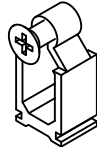
Ref.	Esquema	Descripción	Ref.	Esquema	Descripción
0701070045		Escuadra 17 x 20 extrusión	0901330006		Juego tapa inversora Reducida
0701070046		Escuadra 11 x 9 extrusión	0701170004		Juego tapa inversora
0701070048		Escuadra 36 x 20 extrusión	1103170002		Tapa salida agua
0701070049		Escuadra 17 x 26 extrusión	XXXXXXXXXX		Pieza Guia
0708090001		Escuadra alineamiento	XXXXXXXXXX		Pieza clip solape GALI-1144
0701070035		Tope travesaño 36 mm			
0701070047		Tope travesaño 17 mm			

## Relación de juntas

RT74 H.O. C16 - C2

Ref.	Esquema	Descripción	Ref.	Esquema	Descripción
0803150008		Junta estanqueidad central (EPDM)	0803050012		Junta acristalamiento precortada 5 mm
0803150009		Junta central suplemento térmico (Espumosa)	0803050013		Junta acristalamiento precortada 6-7 mm
0803040016		Junta central (Espumosa)	0803050014		Junta acristalamiento precortada 8-9 mm
0803050002		Junta interior (espumosa)	0803050015		Junta acristalamiento precortada 10 mm
0803040017		Junta acristalamiento exterior fijos	3001430006		Junta suplemento térmico bajo vidrio (celular)
0803050010		Junta acristalamiento precortada 3 mm	XXXXXXXXXX		Relleno térmico marco
0803050011		Junta acristalamiento precortada 4 mm	XXXXXXXXXX		Relleno térmico Hojas

## Acristamiento

RT74 H.O. C16 - C4

### Acristamiento junquillo 7420

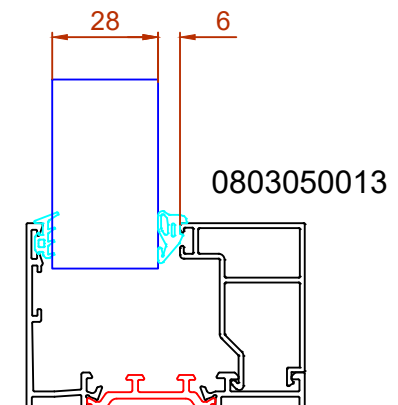
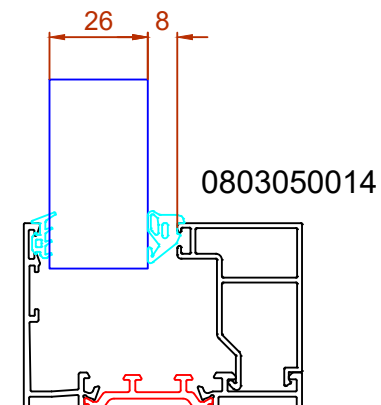
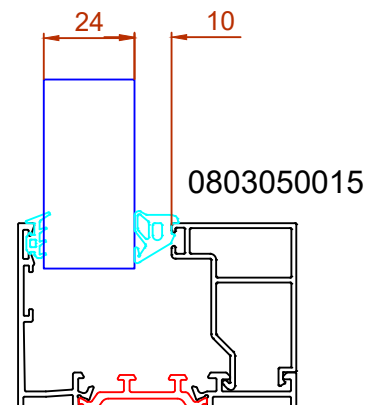

### Acristamiento junquillo 7423

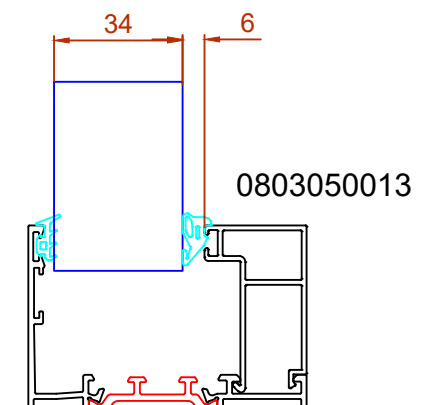
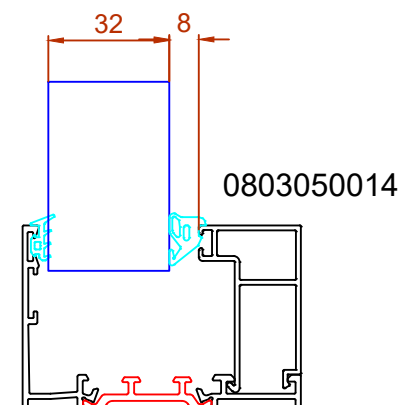
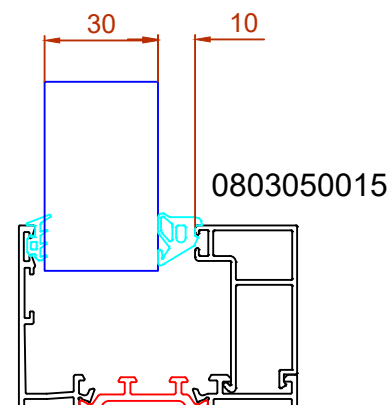



## Acristalamiento

RT74 H.O. C16 - C4

### Acristalamiento Hojas 74021 // 74074

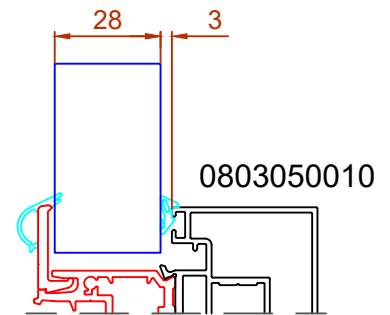
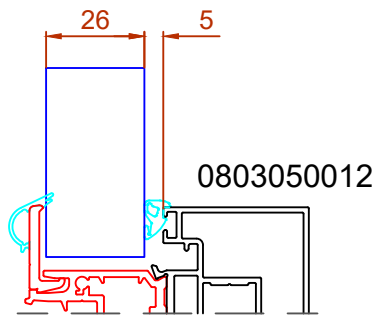
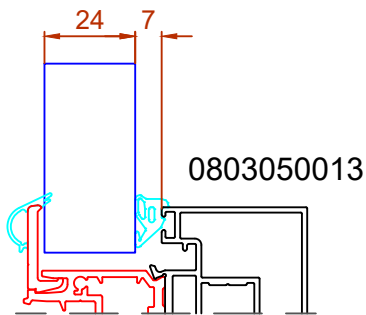

### Acristalamiento Hojas 74076 // 74077 // 74102

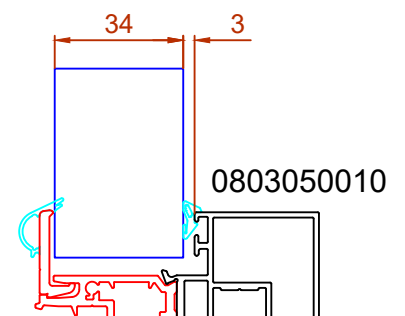
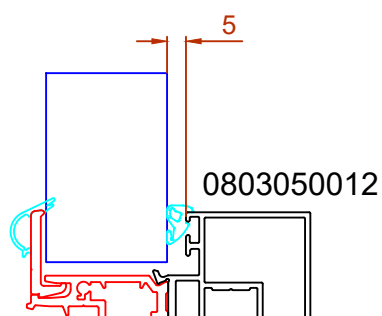
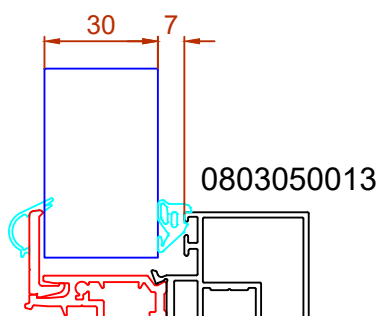

## Perfiles escala 1:1

RT74 H.O. C16 - D1

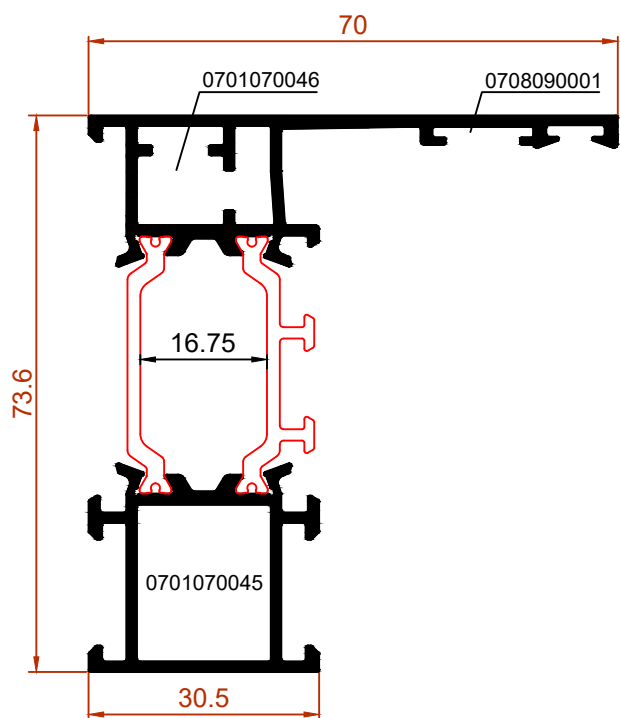

74018

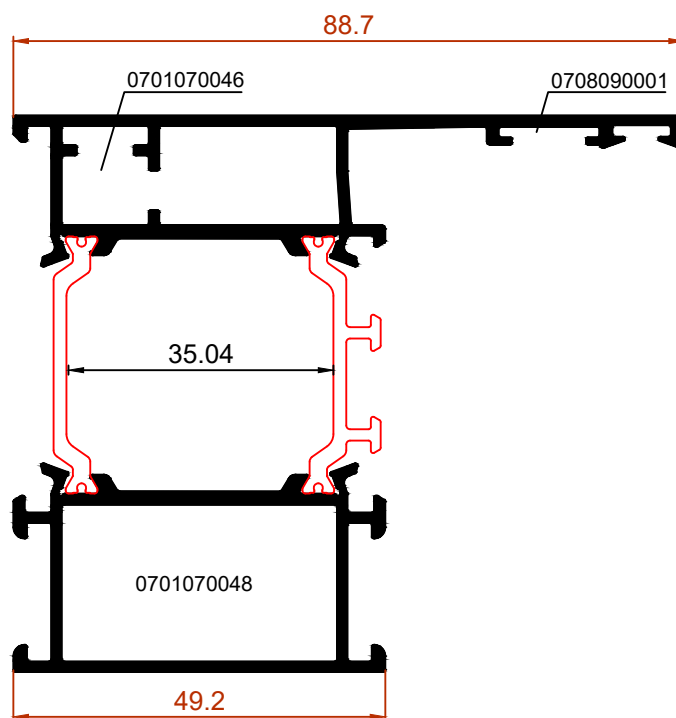

74014

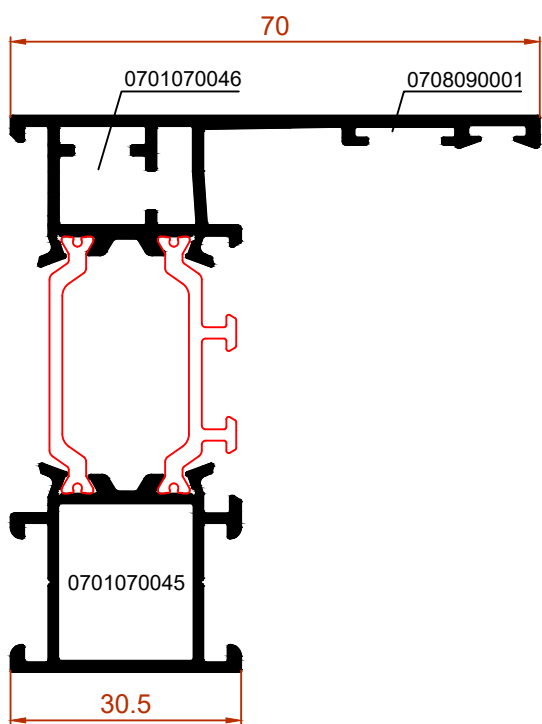

74088

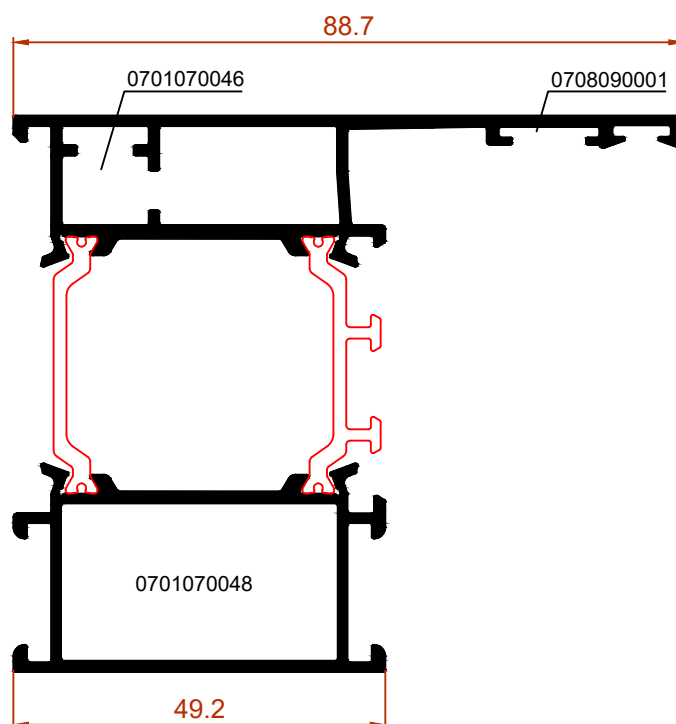

74089

## Perfiles escala 1:1

RT74 H.O. C16 - D2

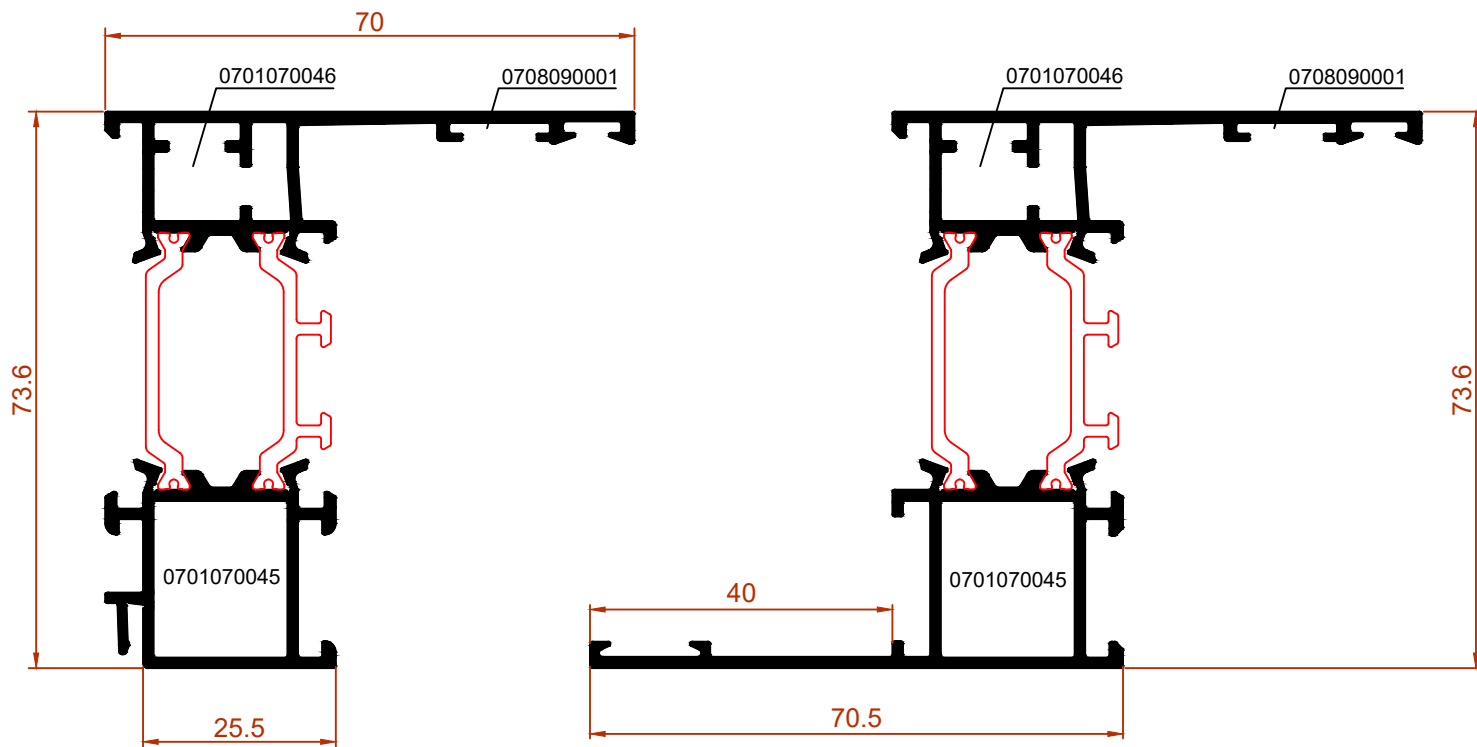

74081

74018L

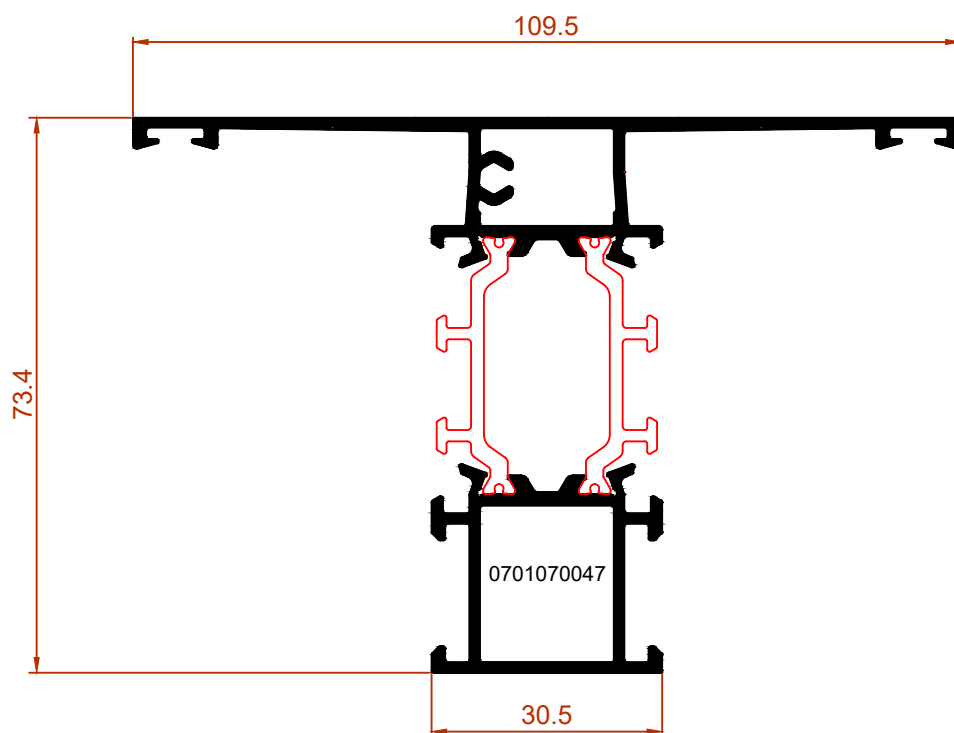

74004  $I_{xx} = 37,56 \text{ cm}^4$   
 $I_{yy} = 23,90 \text{ cm}^4$

## Perfiles escala 1:1

RT74 H.O. C16 - D3

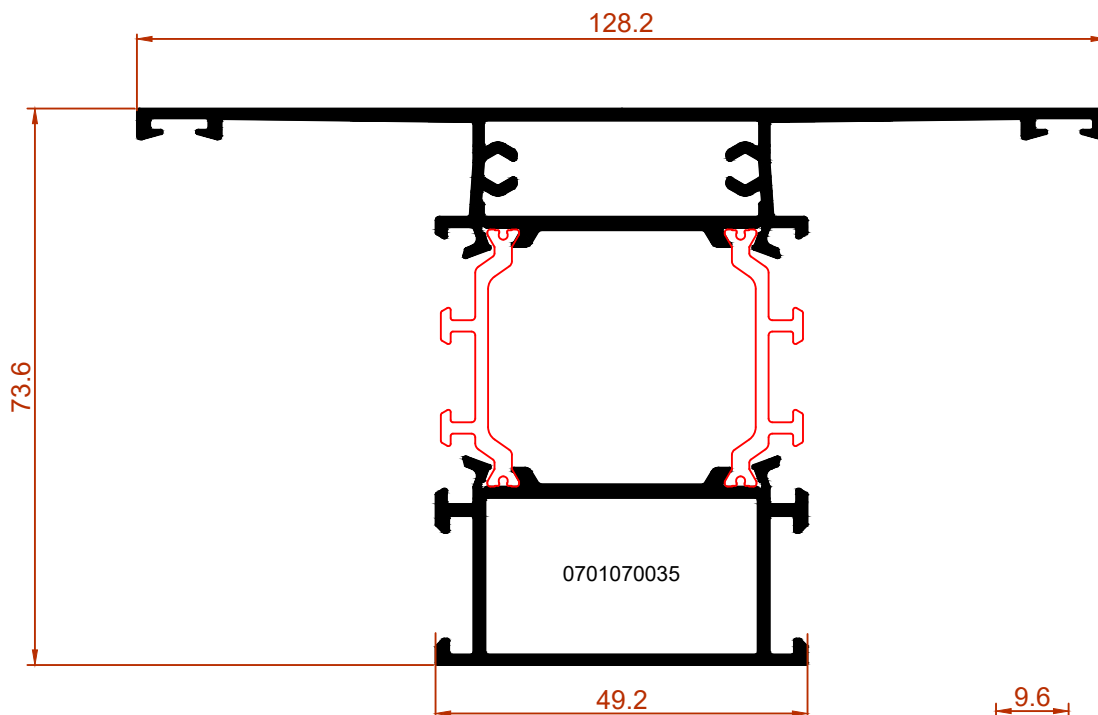

**74013**  $I_{xx} = 49,61 \text{ cm}^4$   
 $I_{yy} = 44,79 \text{ cm}^4$

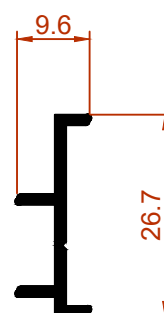

**GALI-1022**

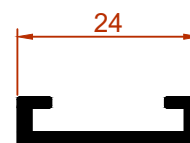

**GFT-39**

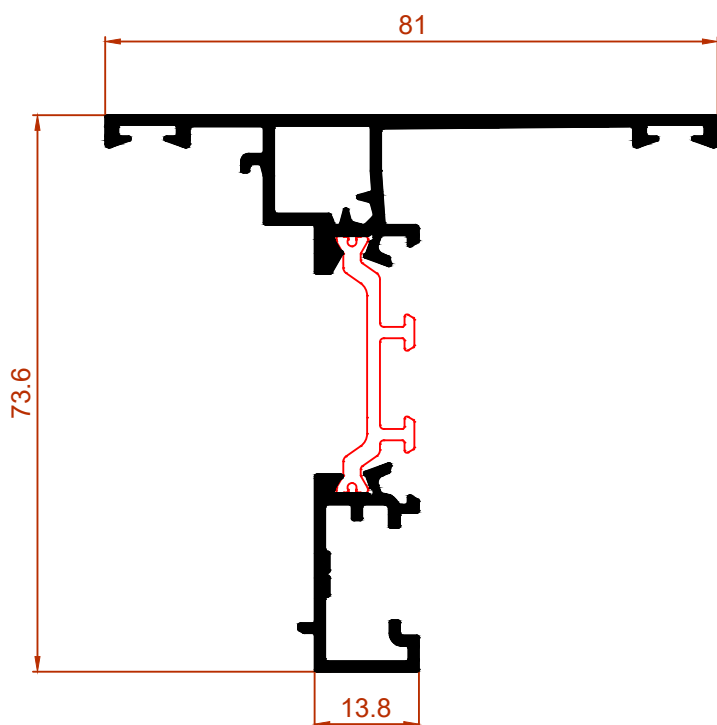

**74075**



**GALI-1147**

## Perfiles escala 1:1

RT74 H.O. C16 - D4

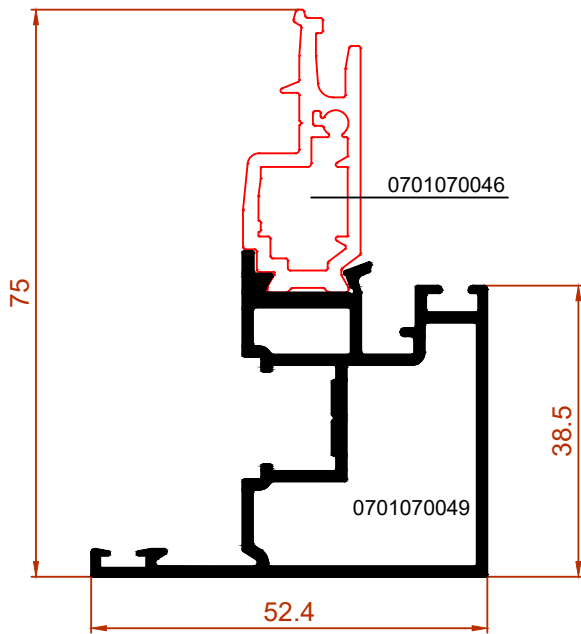

74021

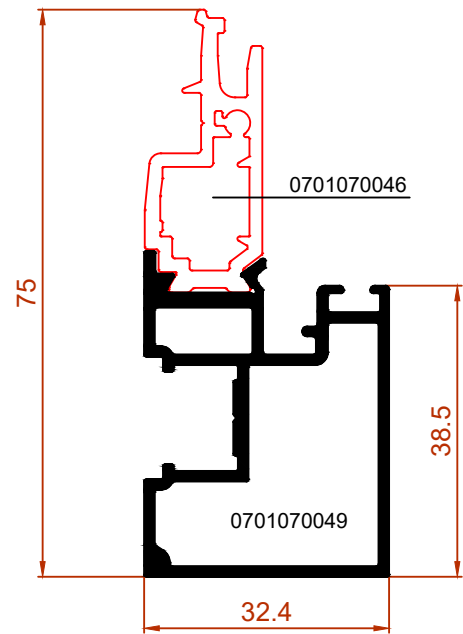

74074

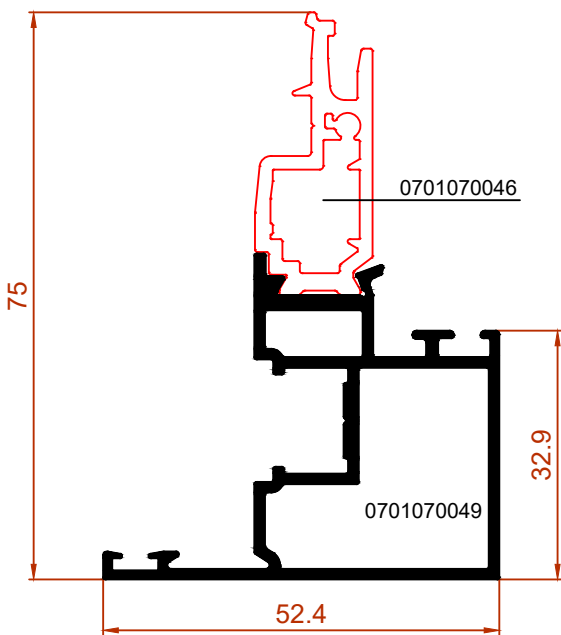

74076

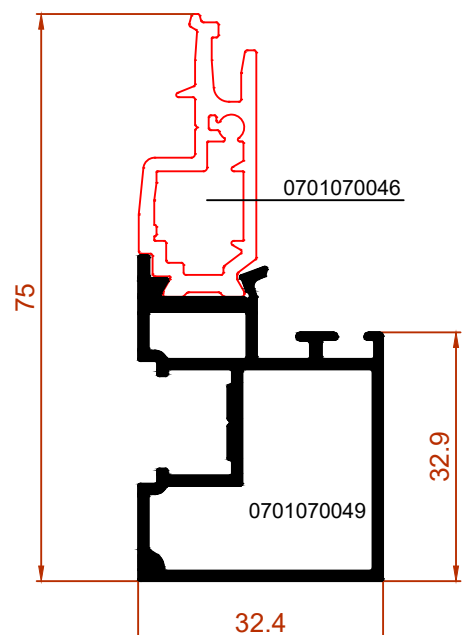

74077

## Perfiles escala 1:1

RT74 H.O. C16 - D5

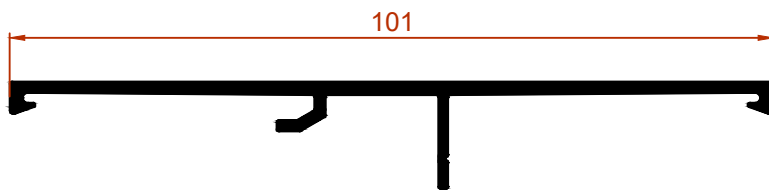

74104

Montaje 74103+74104

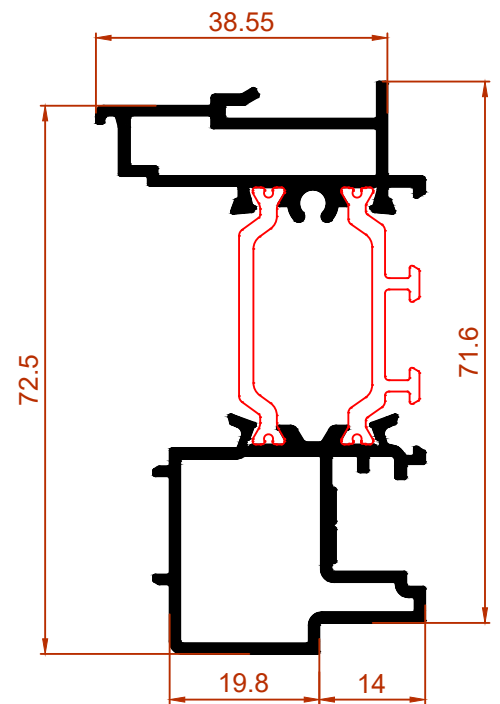
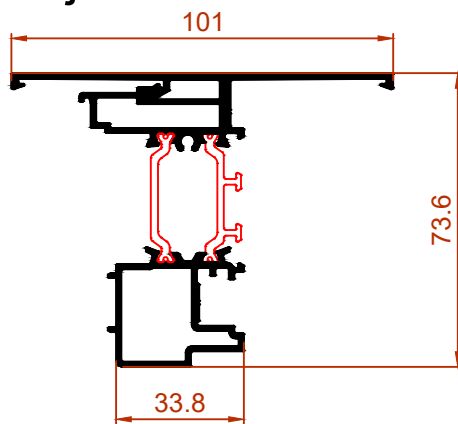

74103

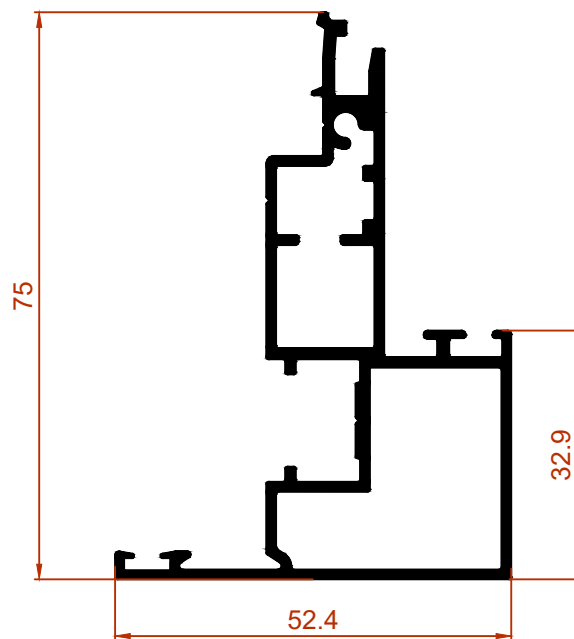

740102

## Perfiles escala 1:1

RT74 H.O. C16 - D6

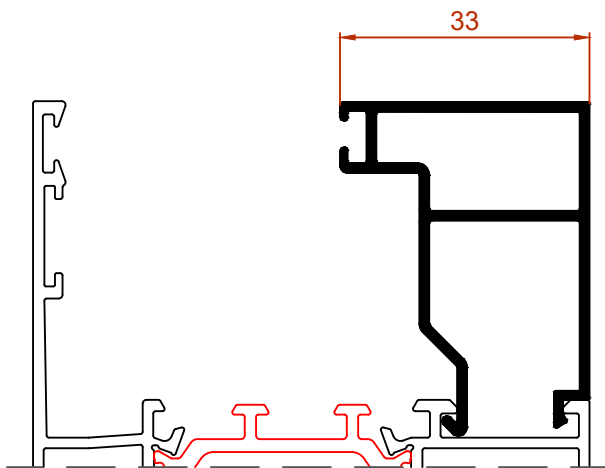

74020

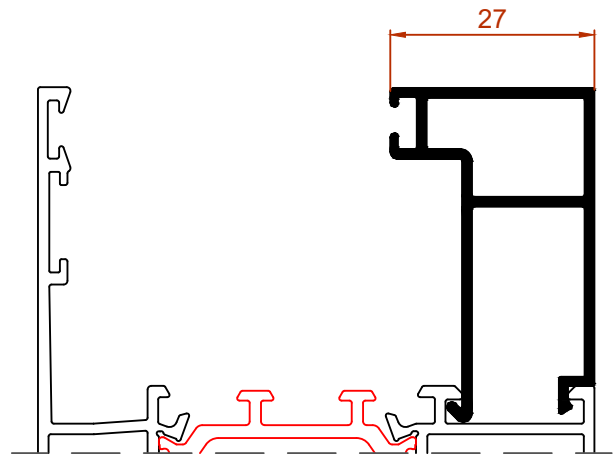

74023

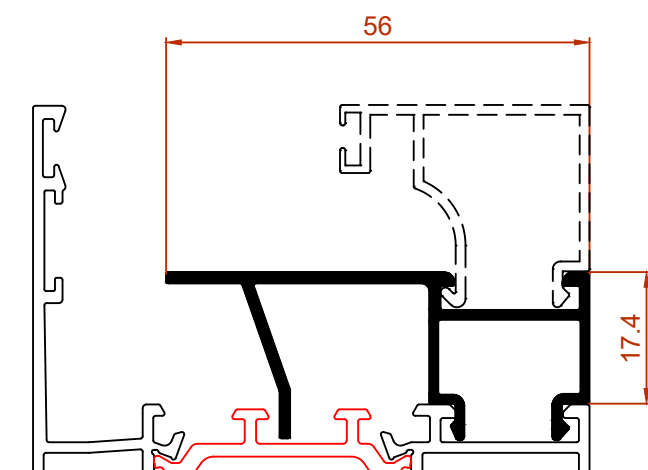

GALI-1148

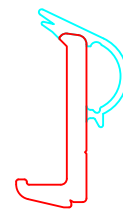

0803050009  
(Perfil en PVC)

## Perfiles escala 1:1

RT74 H.O. C16 - D7

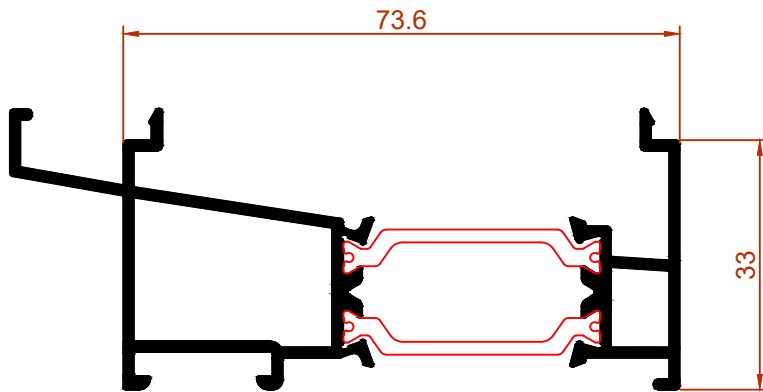

74024

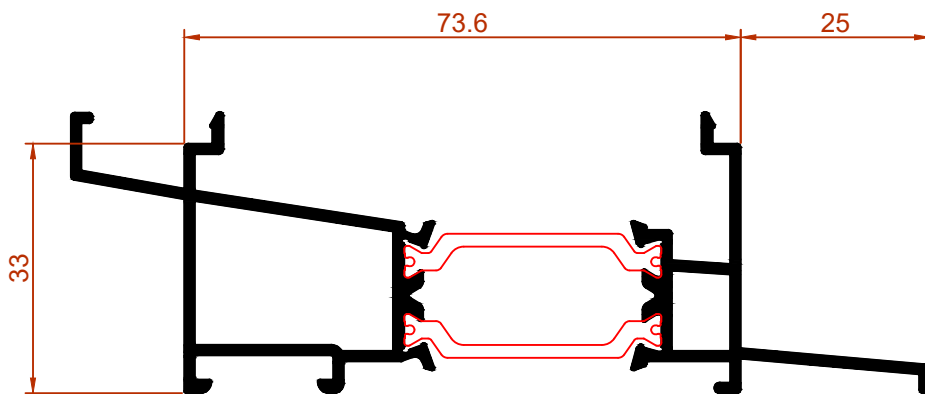

74005

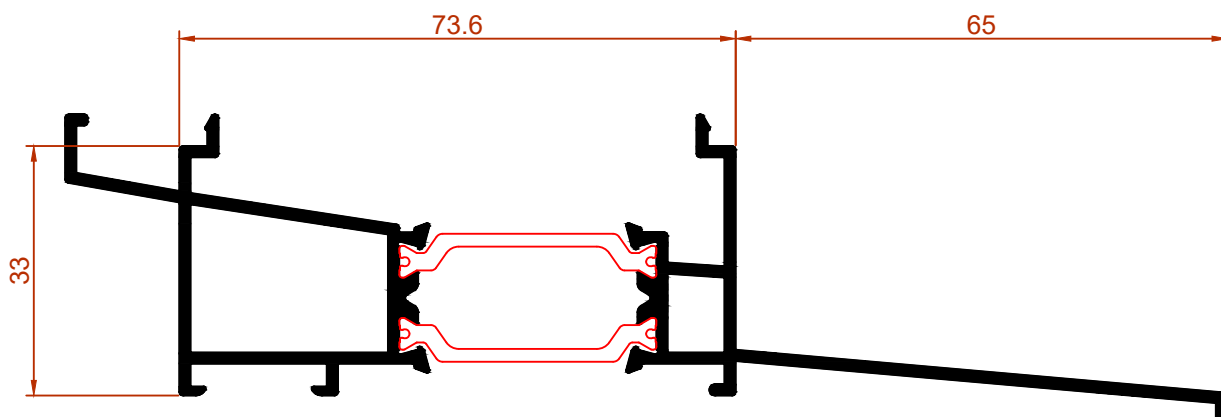

74006



## Perfiles escala 1:1

RT74 H.O. C16 - D8

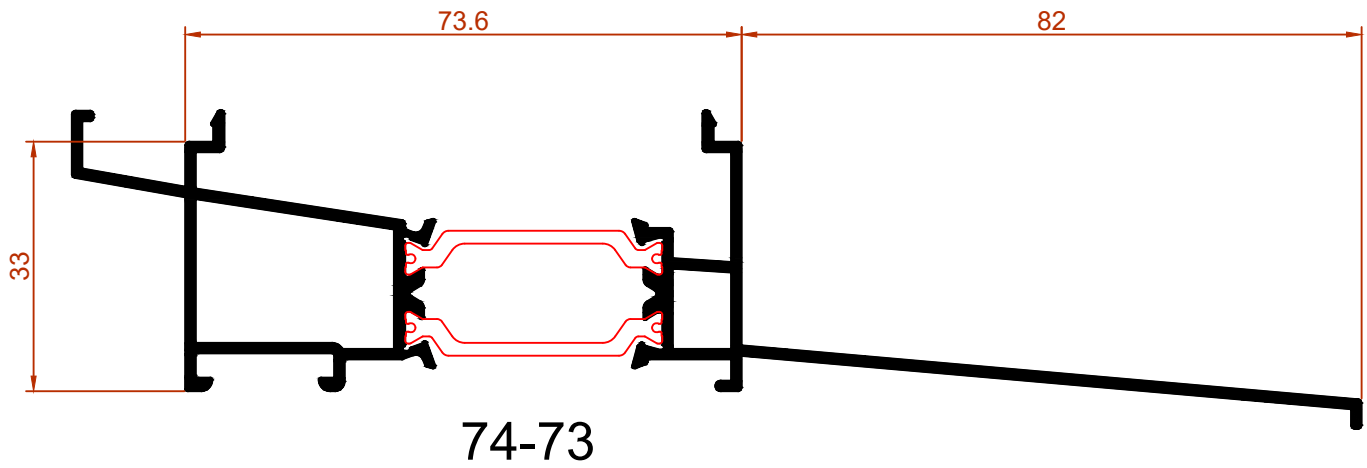

## Perfiles escala 1:1

RT74 H.O. C16 - D9

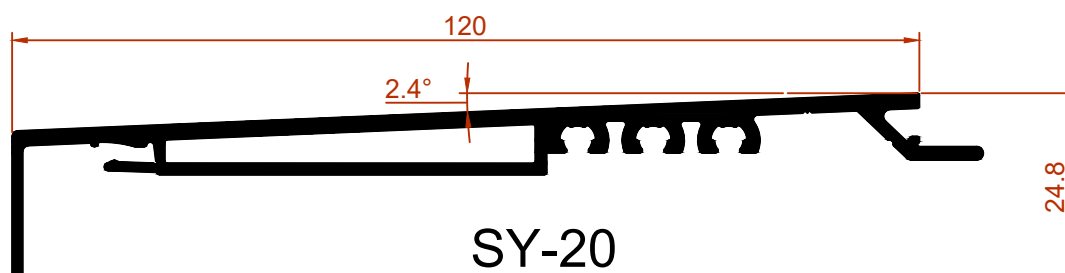
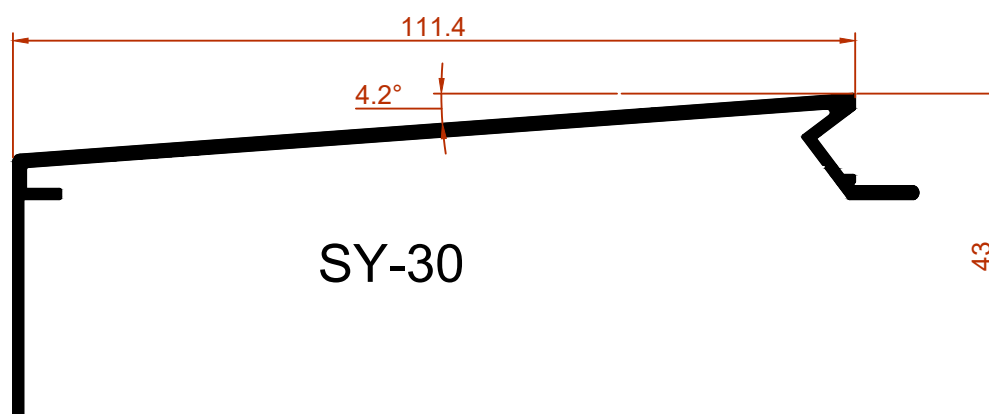
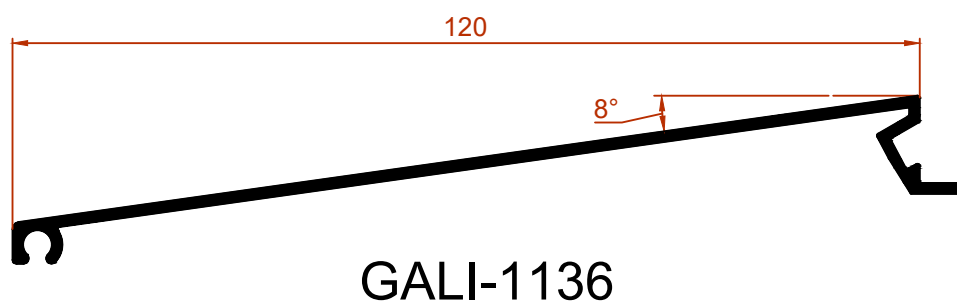
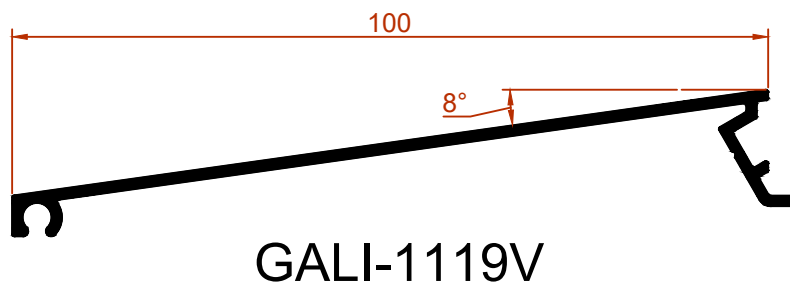
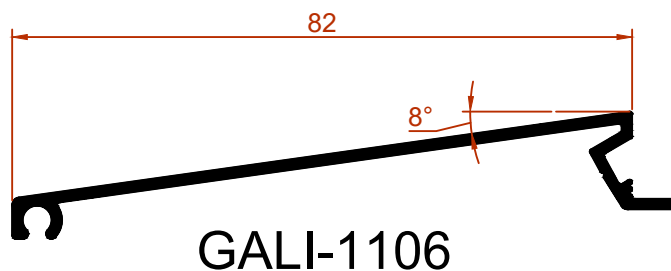

## Perfiles escala 1:1

RT74 H.O. C16 - D10

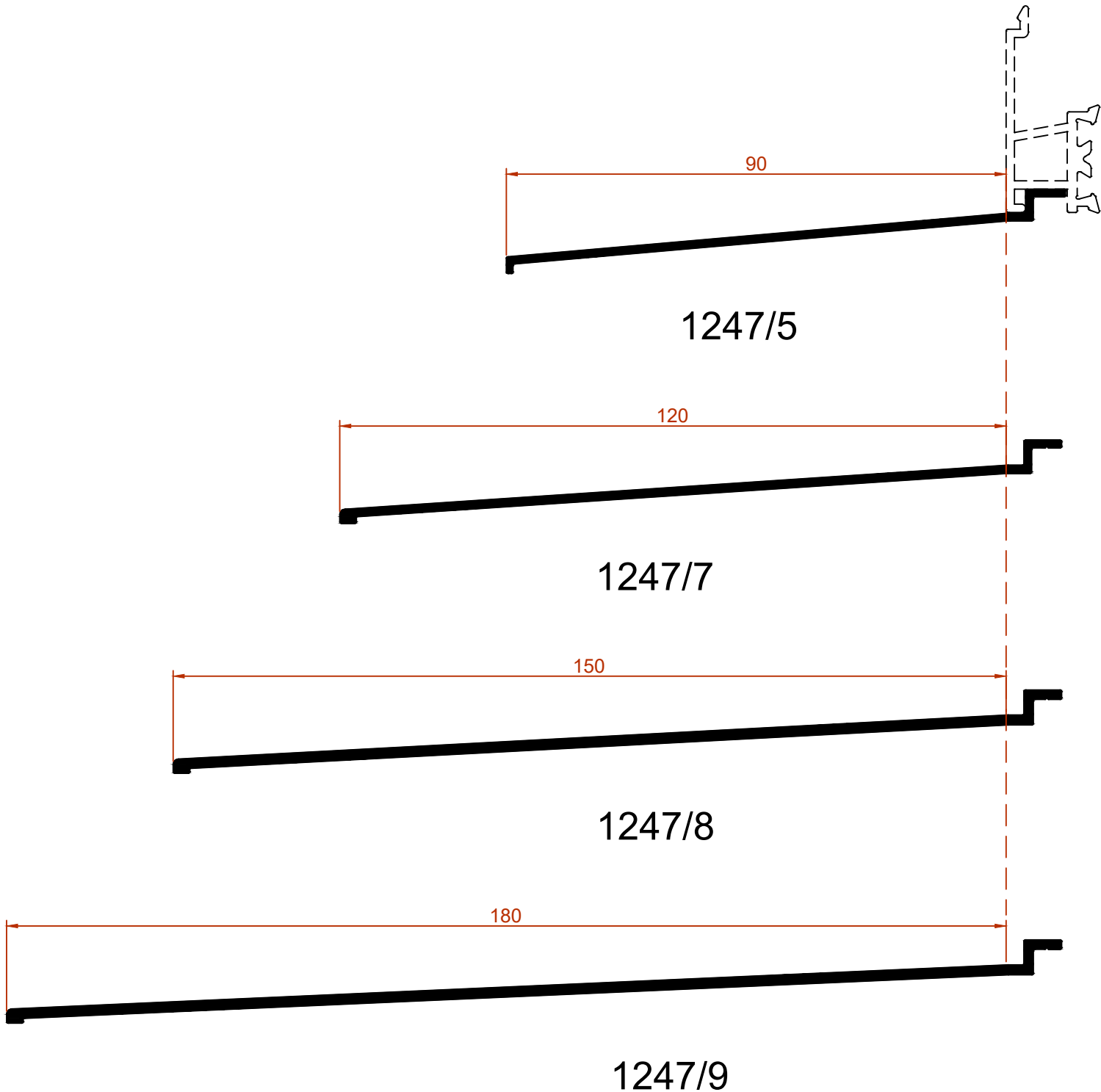

## Perfiles escala 1:1

RT74 H.O. C16 - D11

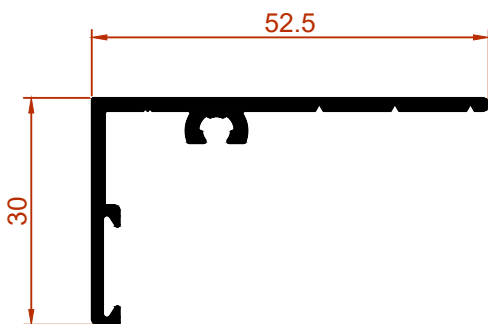
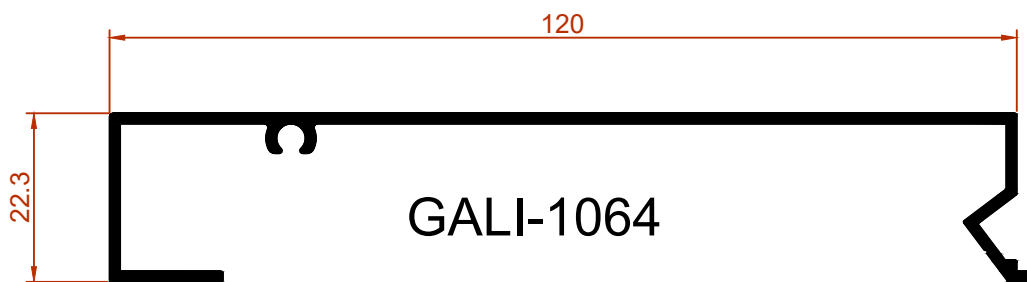
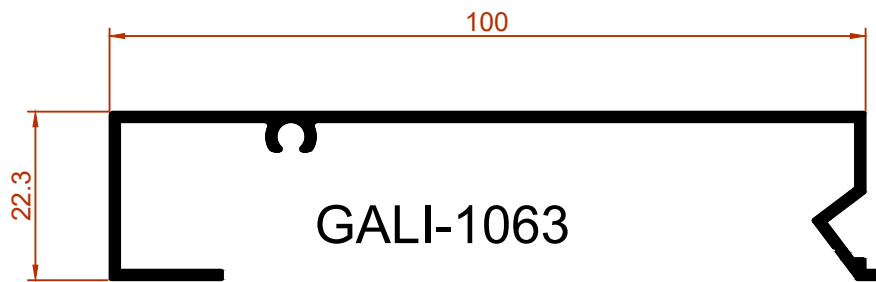

SY-11

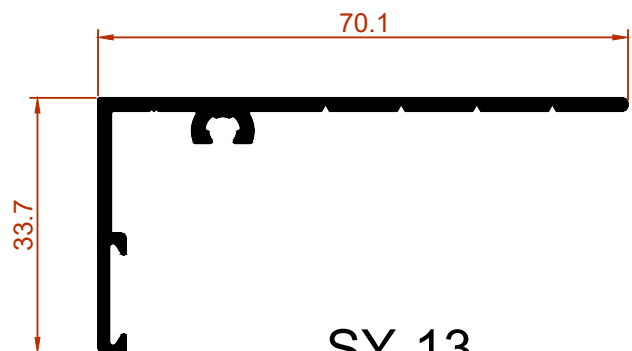

SY-13

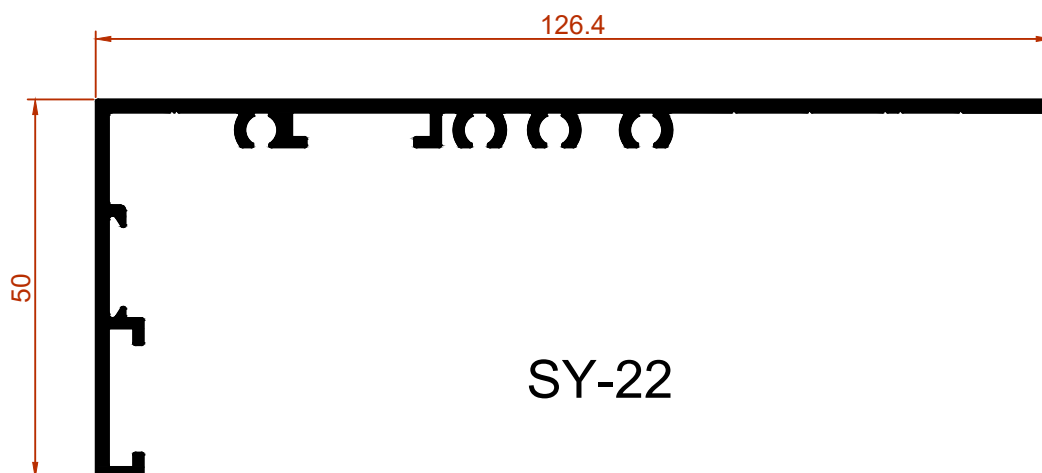

SY-22

## Perfiles escala 1:1

RT74 H.O. C16 - D12

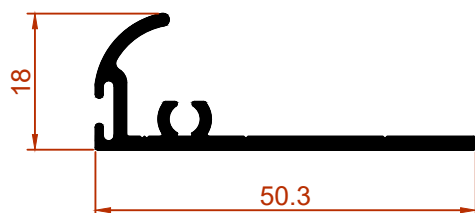

SY-21

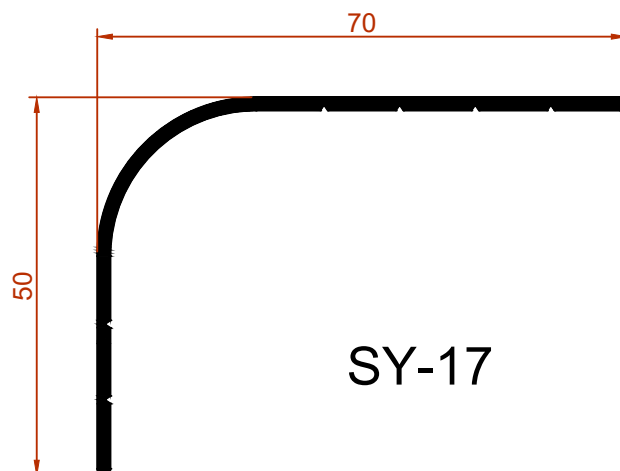

SY-17

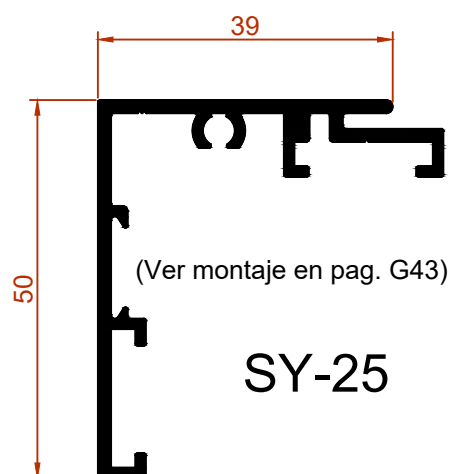

SY-25

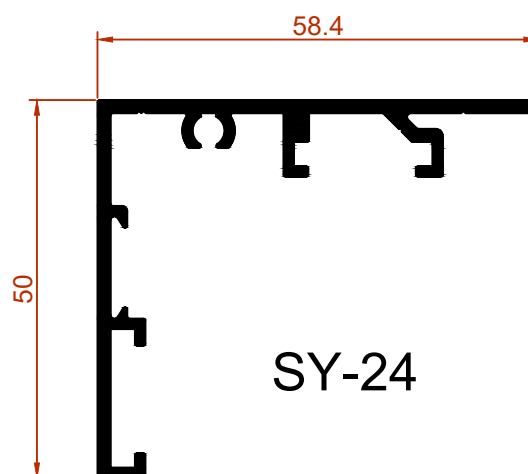

SY-24

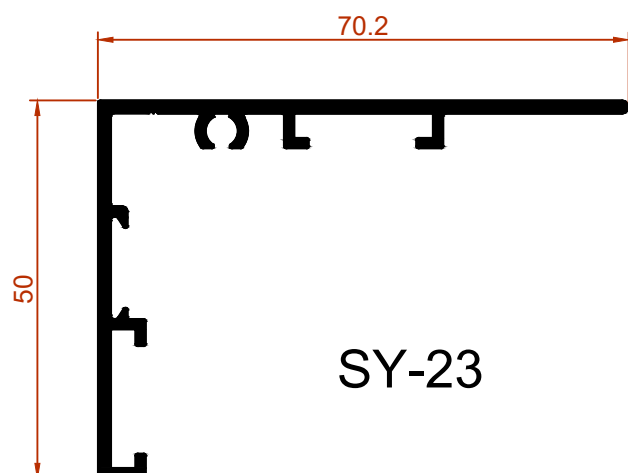

SY-23

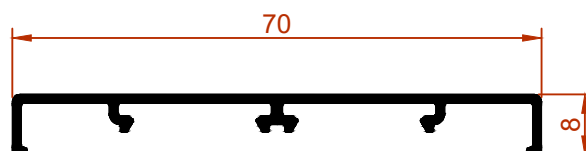

GALI-1124

## Perfiles escala 1:1

RT74 H.O. C16 - D13

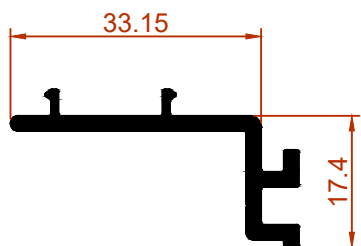

Gali-1006

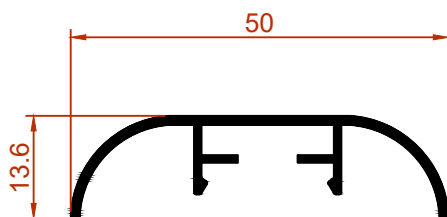

GALI-1007

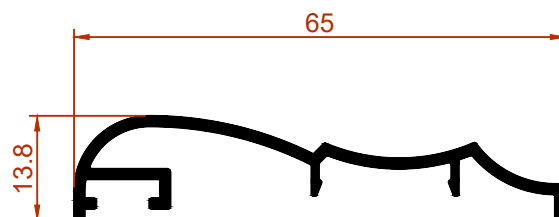

GALI-1078

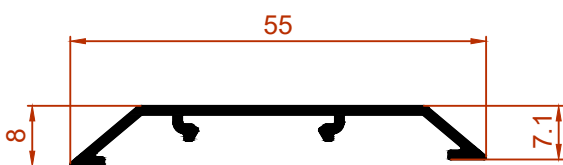

GALI-1134

(Ver montaje en pag. G15 y G23)

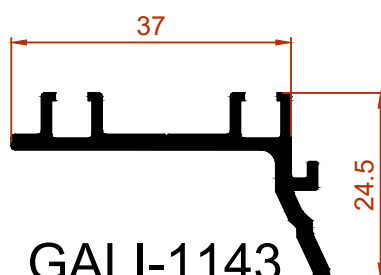

GALI-1143

(Ver montaje en pag. G22)



GALI-1144

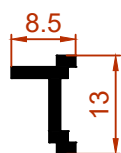

GALI-1135

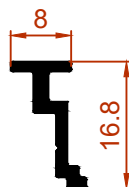

GALI-1145

(Ver montaje en pag. G26)

## Perfiles escala 1:1

RT74 H.O. C16 - D14

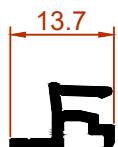

SY-26

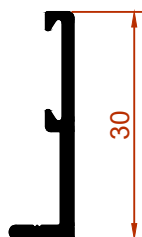

SY-01

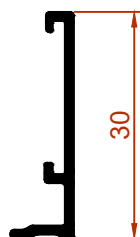

GALI-1116V

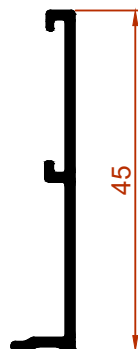

GALI-1118V

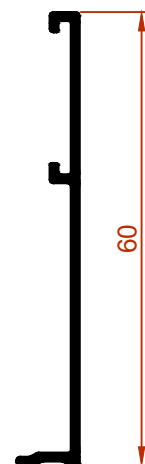

GALI-1126

(Ver montaje en pag. G13 y siguientes)

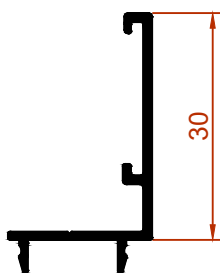

GALI-1115V

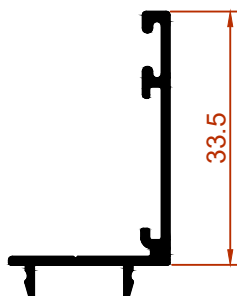

GALI-1085M

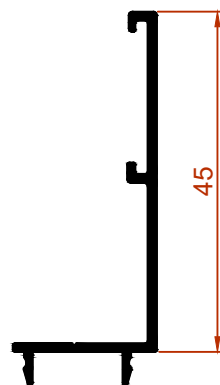

GALI-1117V

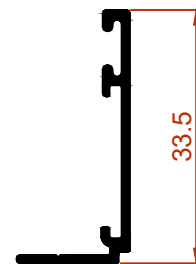

GALI-1086M

(Ver montaje en pag. G18)

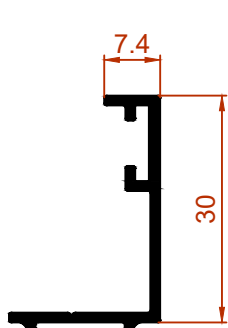

GALI-1142

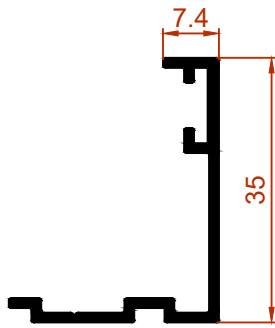

GALI-1140

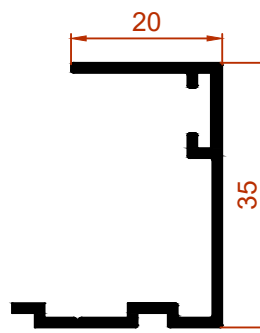

GALI-1141

(Ver montaje en pag. G19, G20 y G21)

## Perfiles escala 1:1

RT74 H.O. C16 - D15

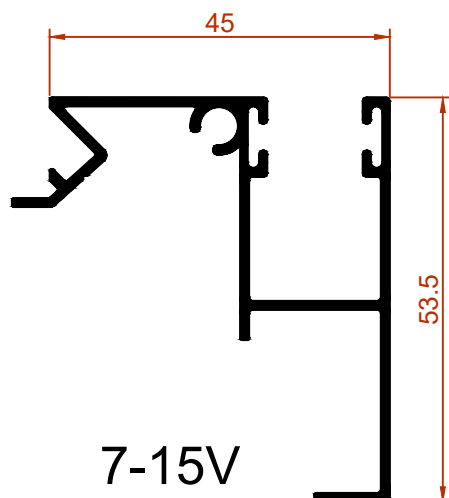

7-15V

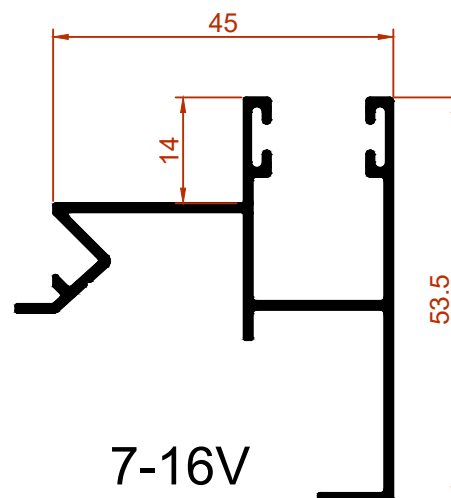

7-16V

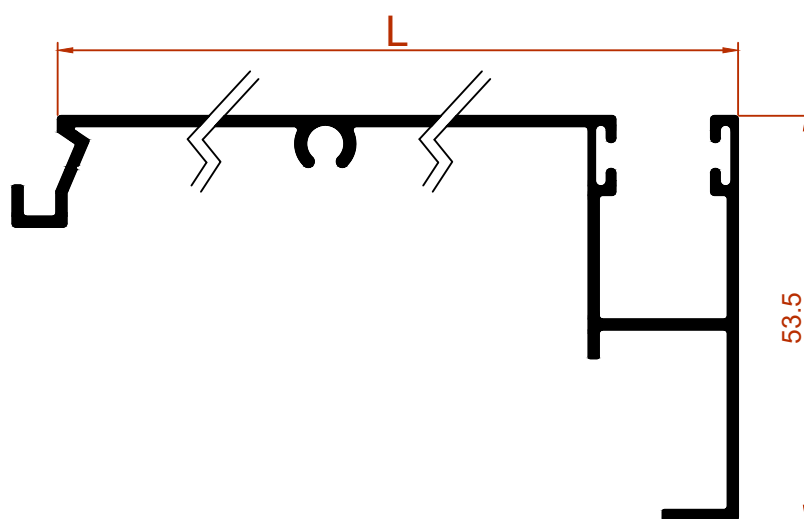

Referencia	Cota L
7-06	60
7-14	64,3
7-13	70
7-08	75
7-11	80

Referencia	Cota L
7-10	90
7-09	95
7-05	104
7-12	120



## Perfiles escala 1:1

RT74 H.O. C16 - D16

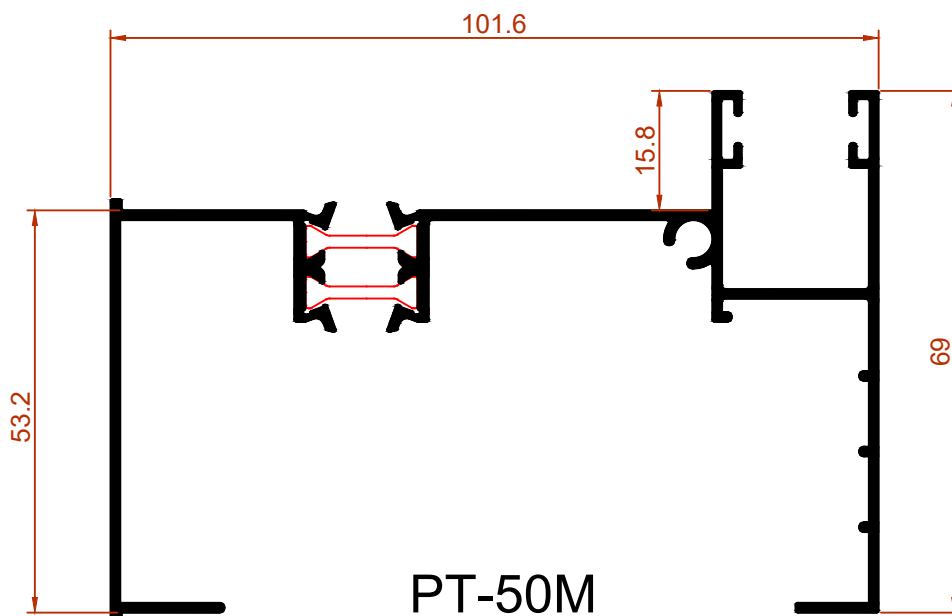
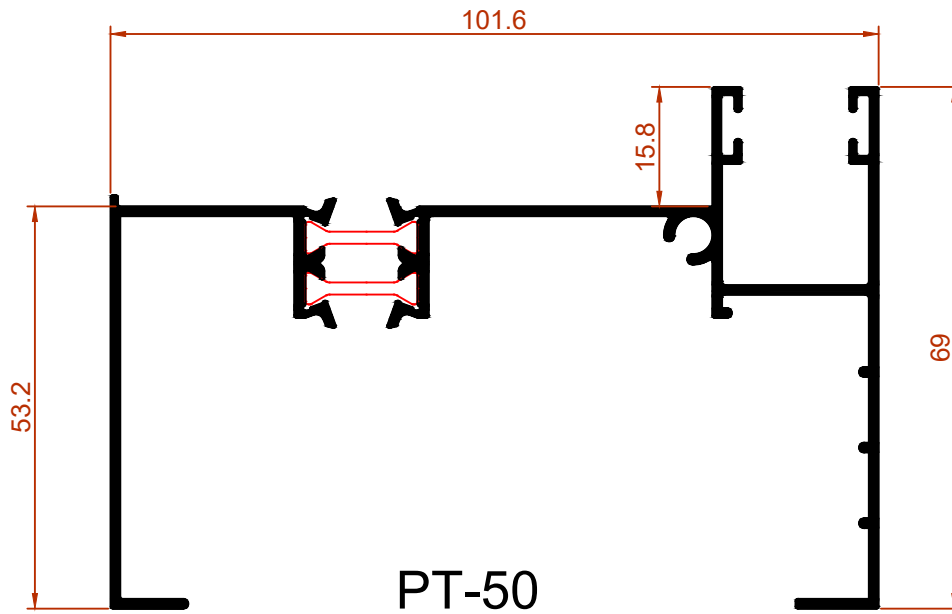

## Perfiles escala 1:1

RT74 H.O. C16 - D17

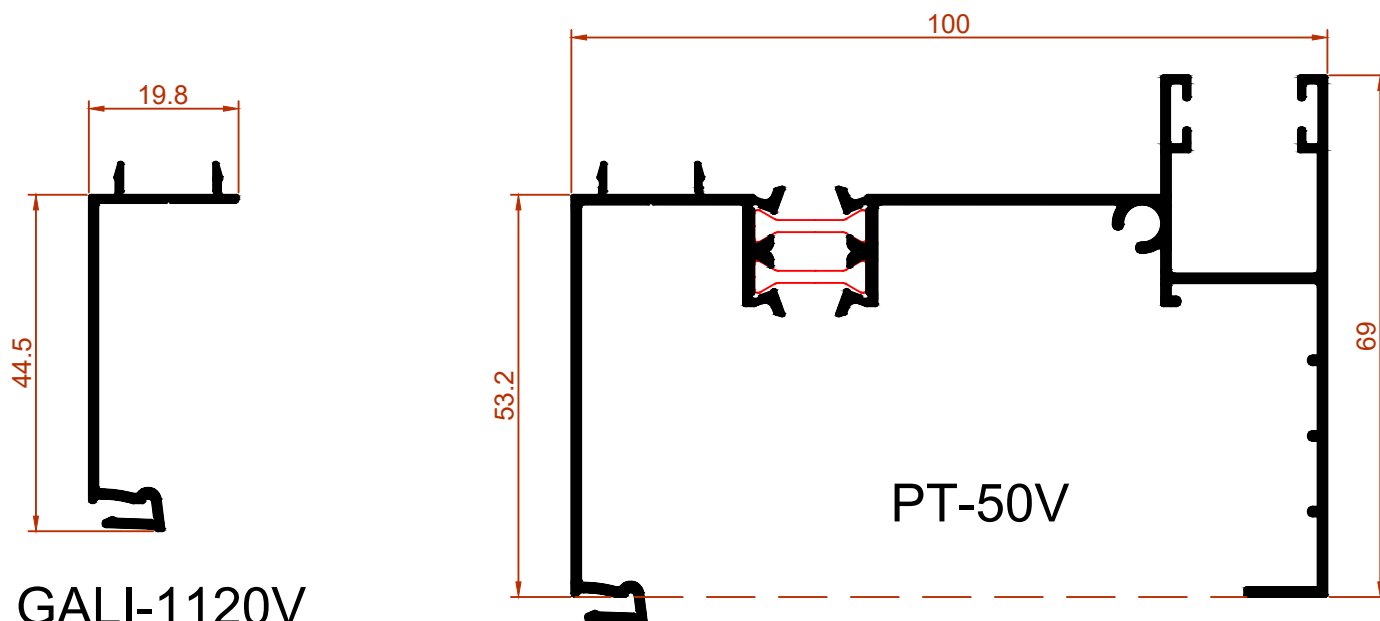

GALI-1120V

(Ver montaje en pag. G40 y siguientes)

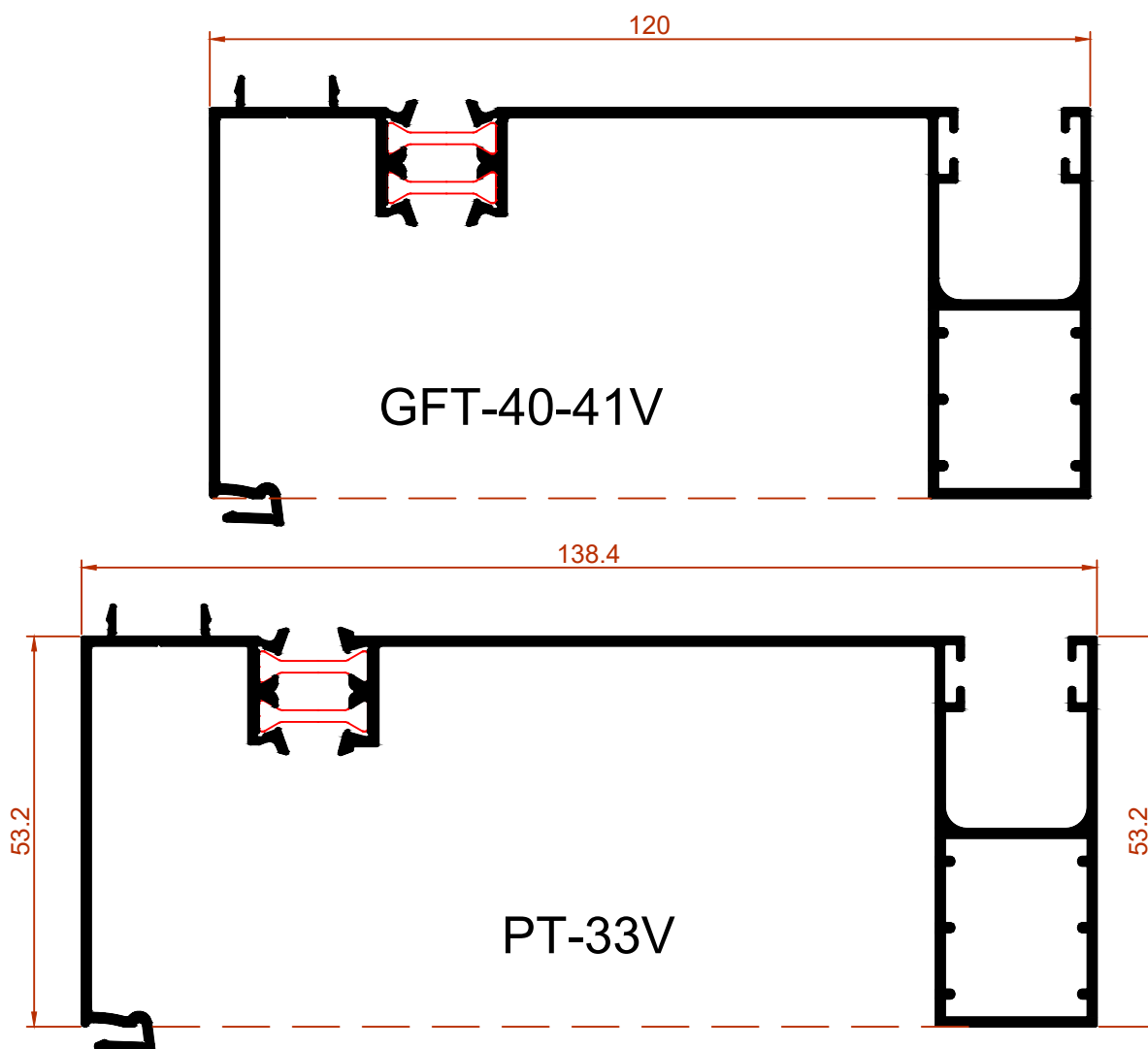

GFT-40-41V

PT-33V

## Perfiles escala 1:1

RT74 H.O. C16 - D18

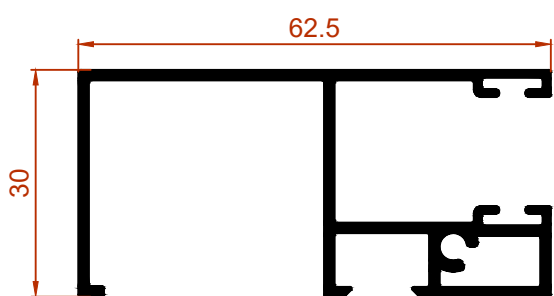
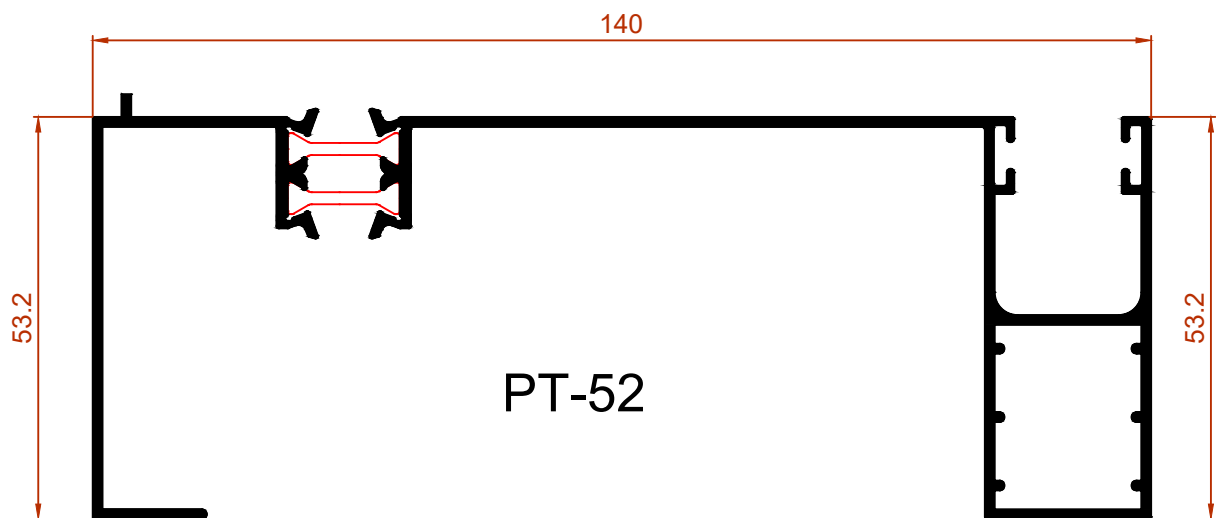
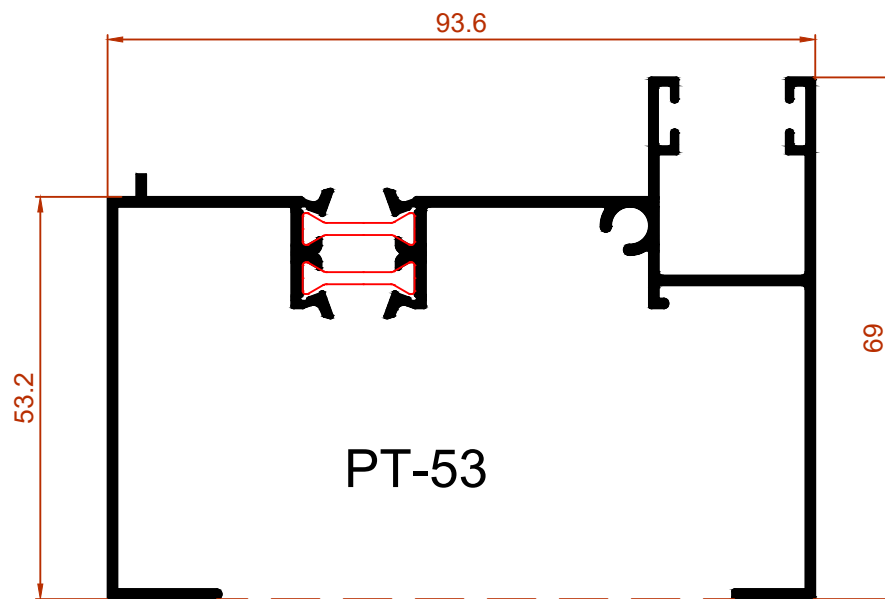

GALI-1132

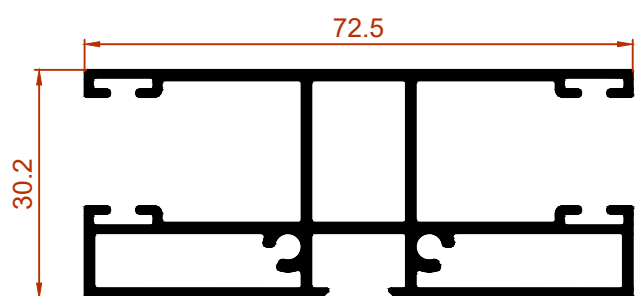

GALI-1133

## Perfiles escala 1:1

RT74 H.O. C16 - D19

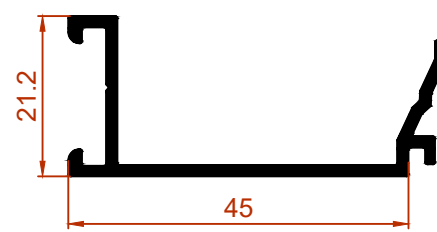
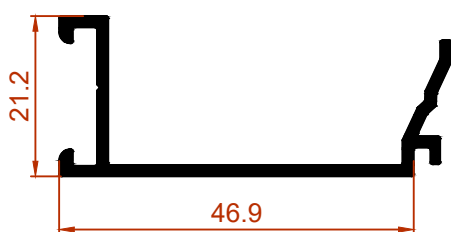
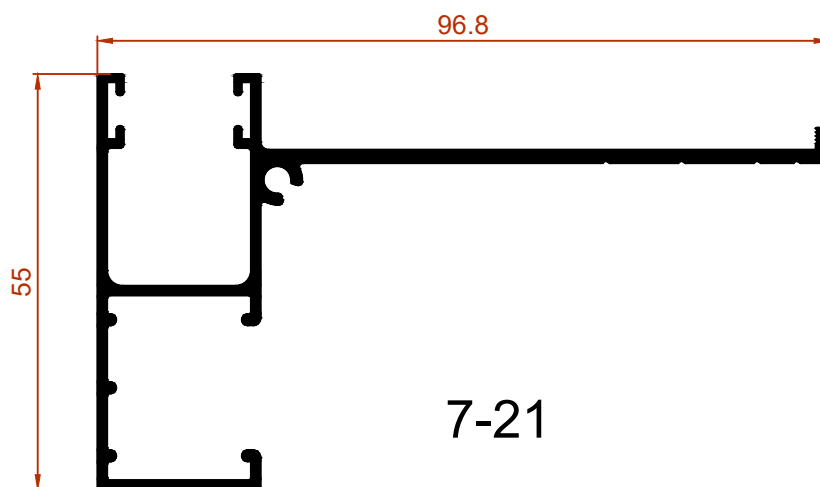
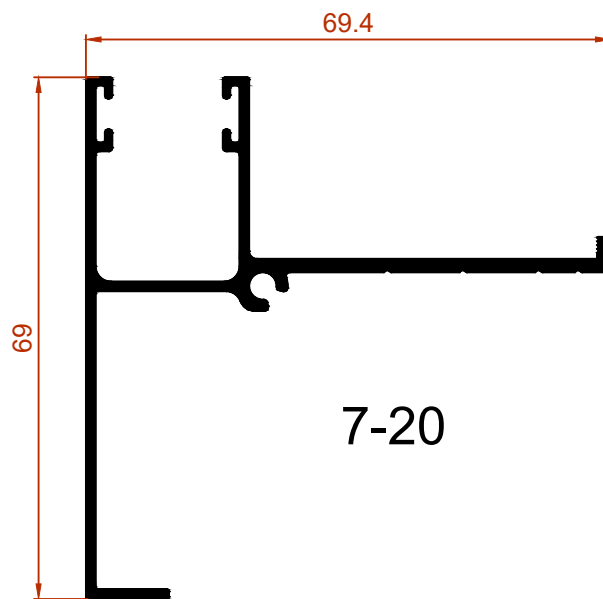

## Perfiles escala 1:1

RT74 C16 - D20

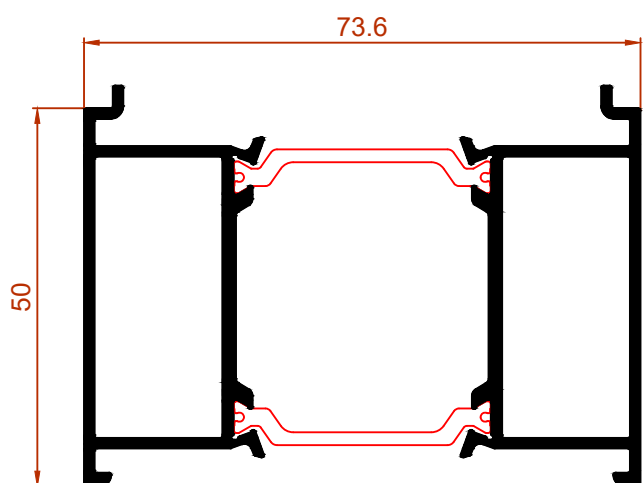

**74-30**  $I_{xx} = 11,00 \text{ cm}^4$   
 $I_{yy} = 33,46 \text{ cm}^4$

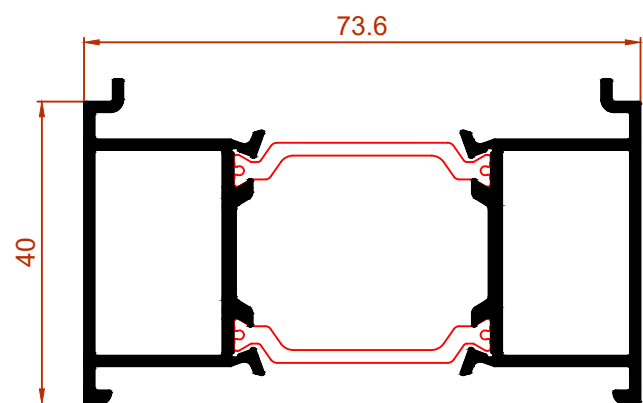

**74-29**  $I_{xx} = 5,77 \text{ cm}^4$   
 $I_{yy} = 28,69 \text{ cm}^4$

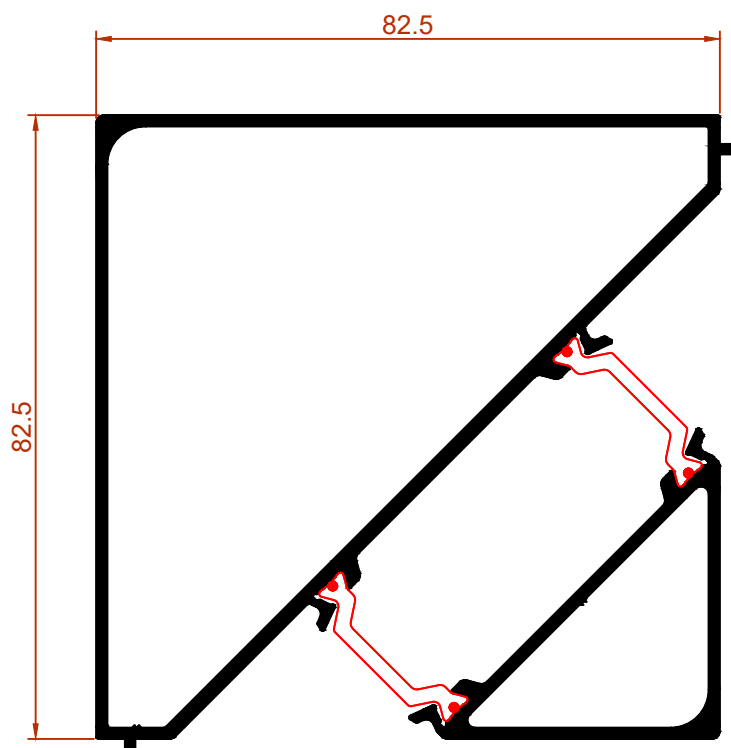

**RTA72-08**  $I_{xx} = 60,20 \text{ cm}^4$   
 $I_{yy} = 60,20 \text{ cm}^4$

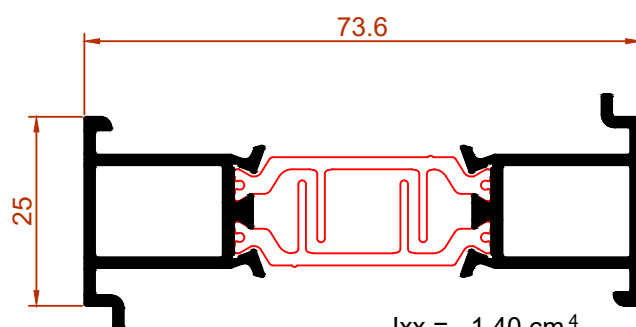

**74-07**  $I_{xx} = 1,40 \text{ cm}^4$   
 $I_{yy} = 21,39 \text{ cm}^4$

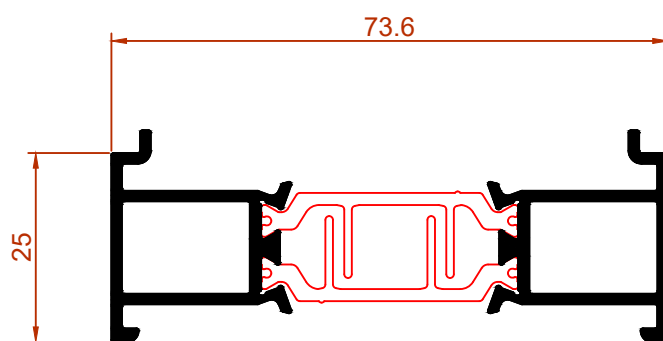

**74-28**  $I_{xx} = 1,39 \text{ cm}^4$   
 $I_{yy} = 21,38 \text{ cm}^4$

## Perfiles escala 1:1

RT74 C16 - D21

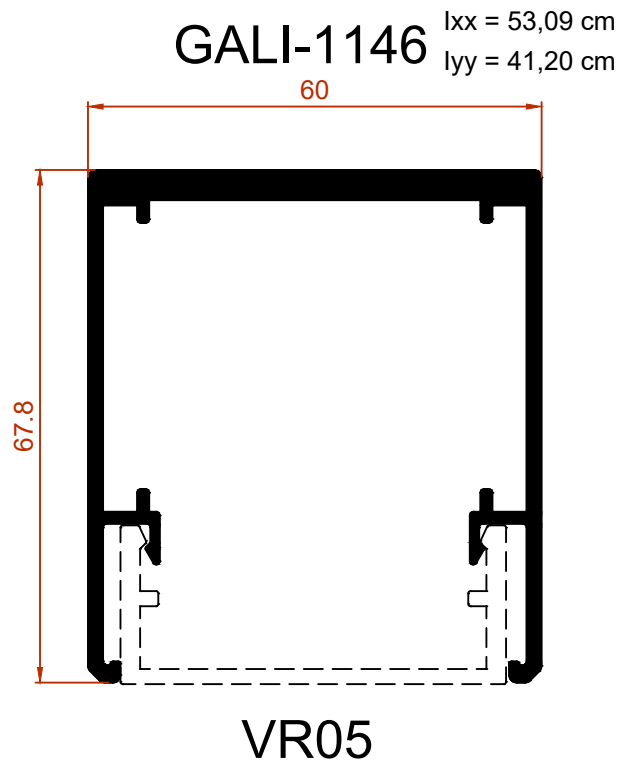

### APERTURA INTERIOR

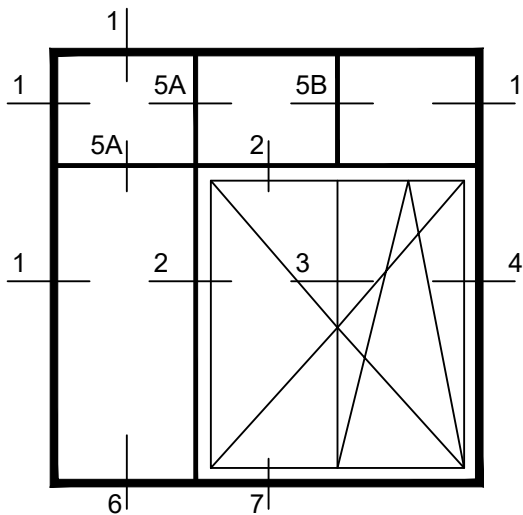

Ventanas

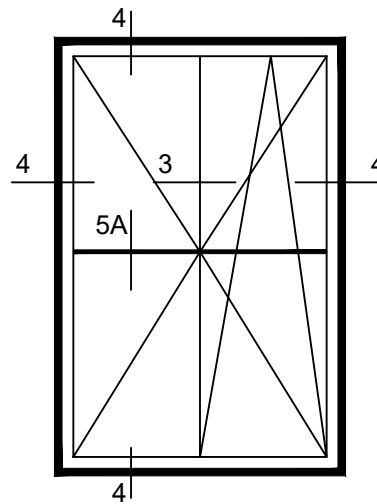

Balconera

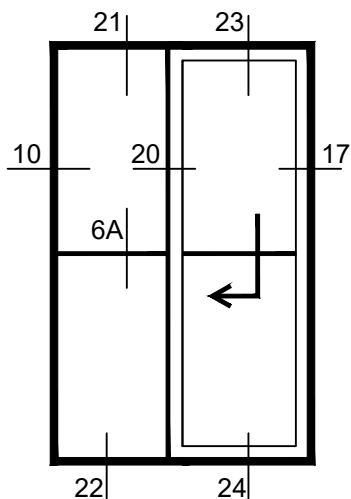

Osciloparalela

## Secciones tipo

RT74 H.O. C16 - G2

0803050015

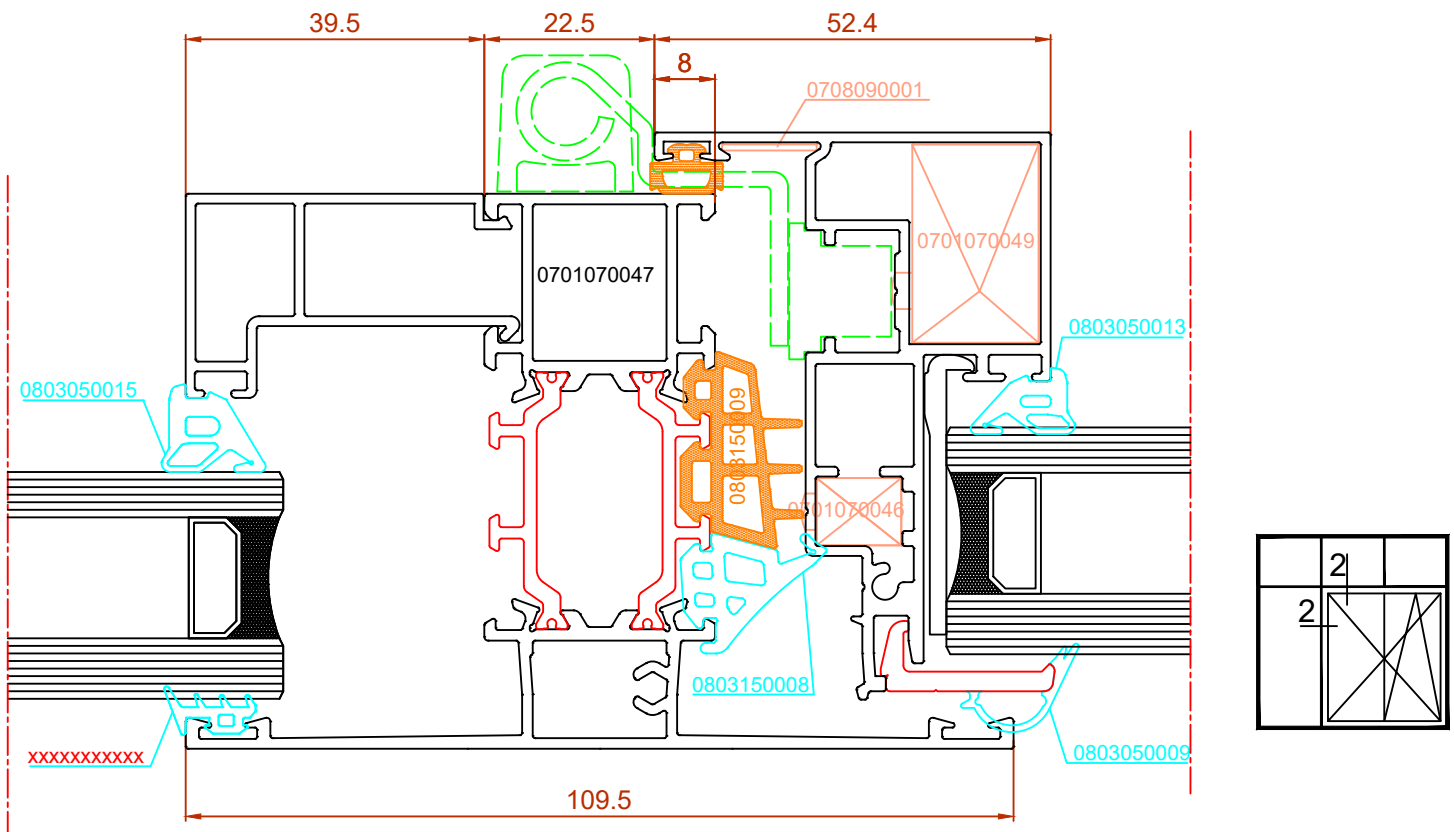
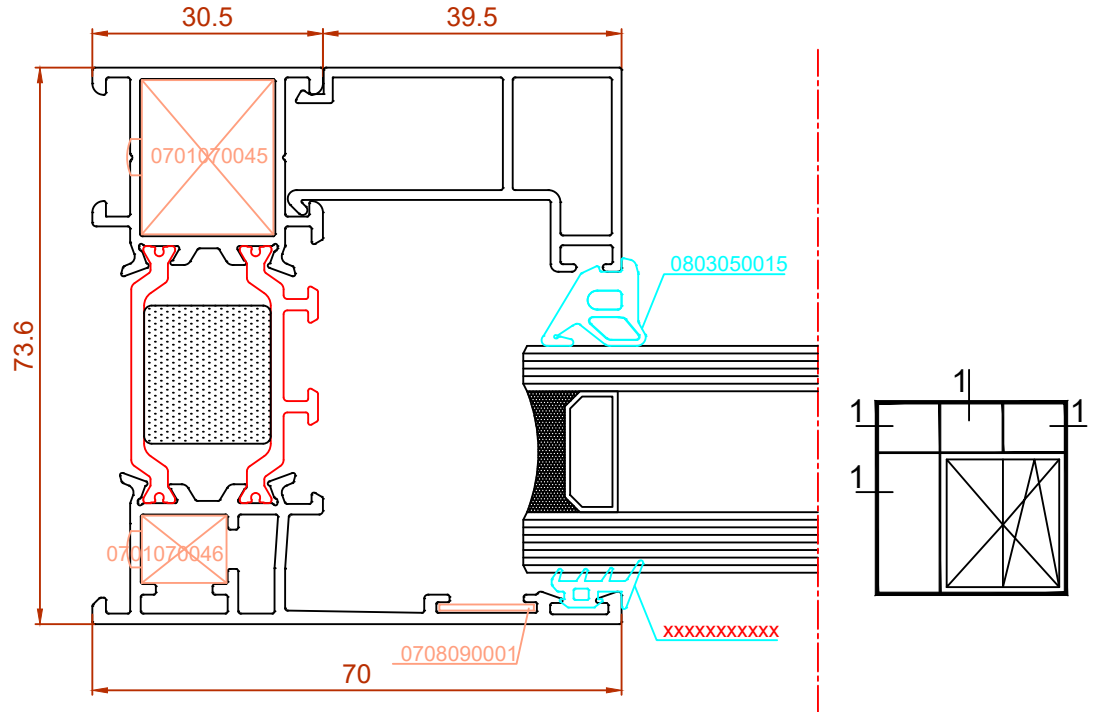



## Secciones tipo

RT74 H.O. C16 - G3

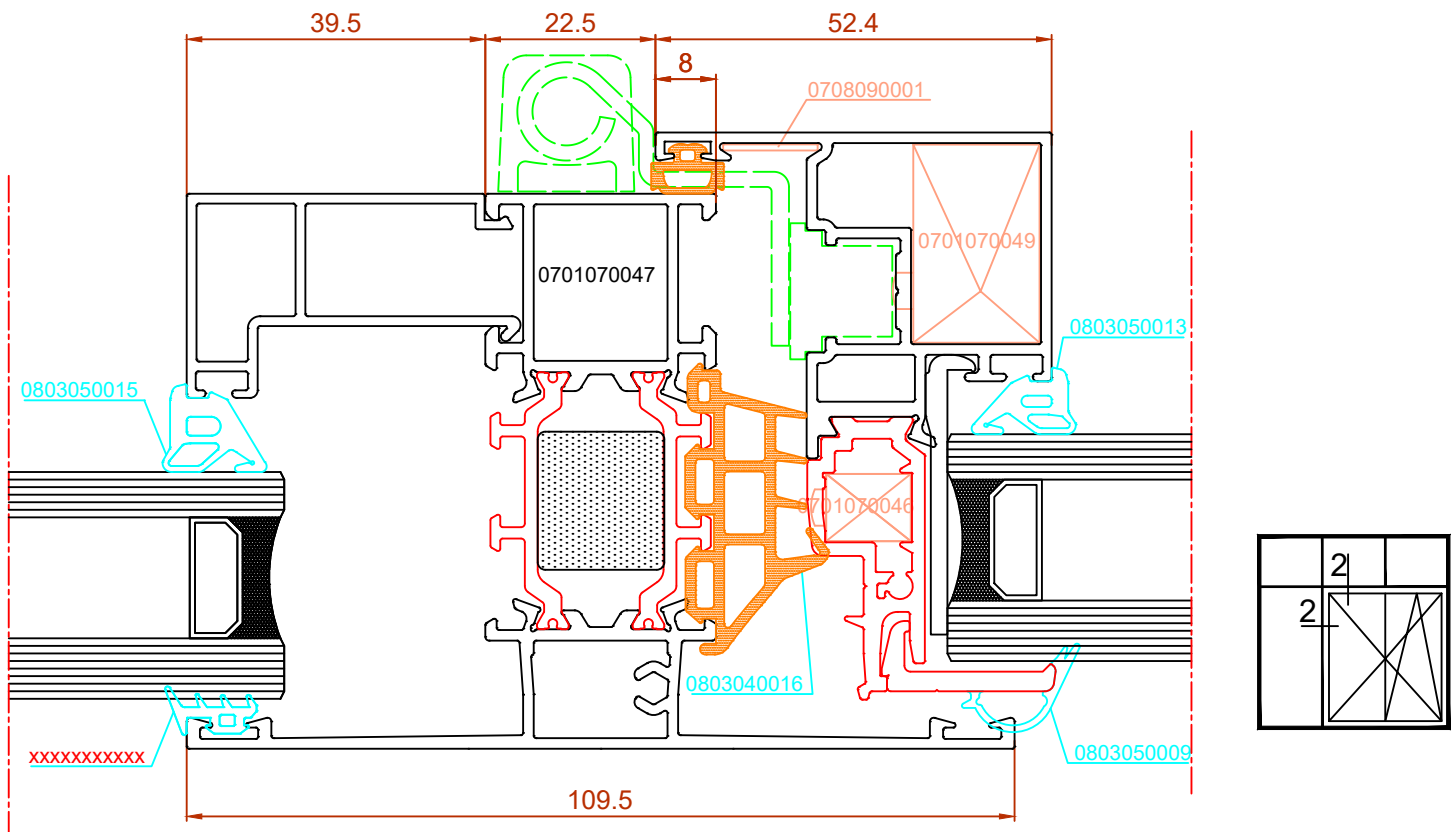
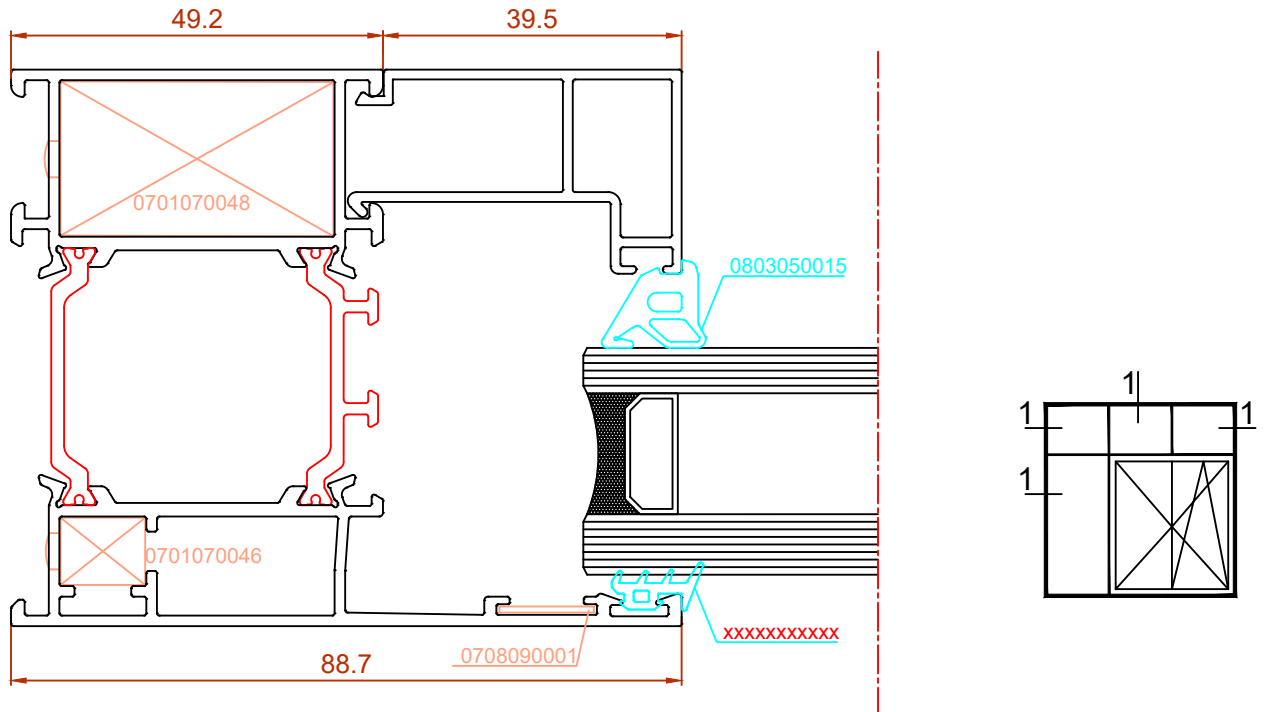

## Secciones tipo

RT74 H.O. C16 - G4

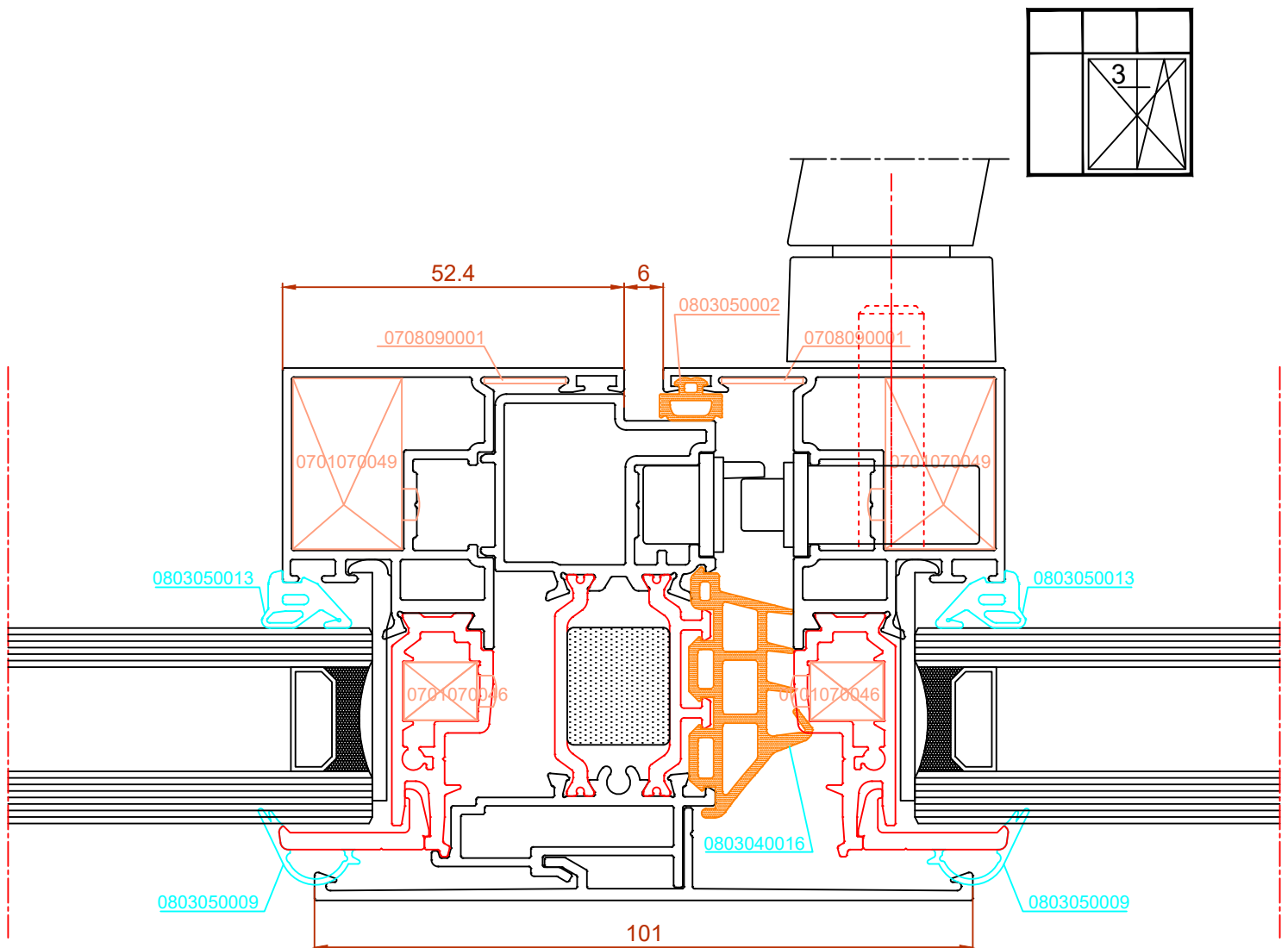

## Secciones tipo

RT74 H.O. C16 - G5

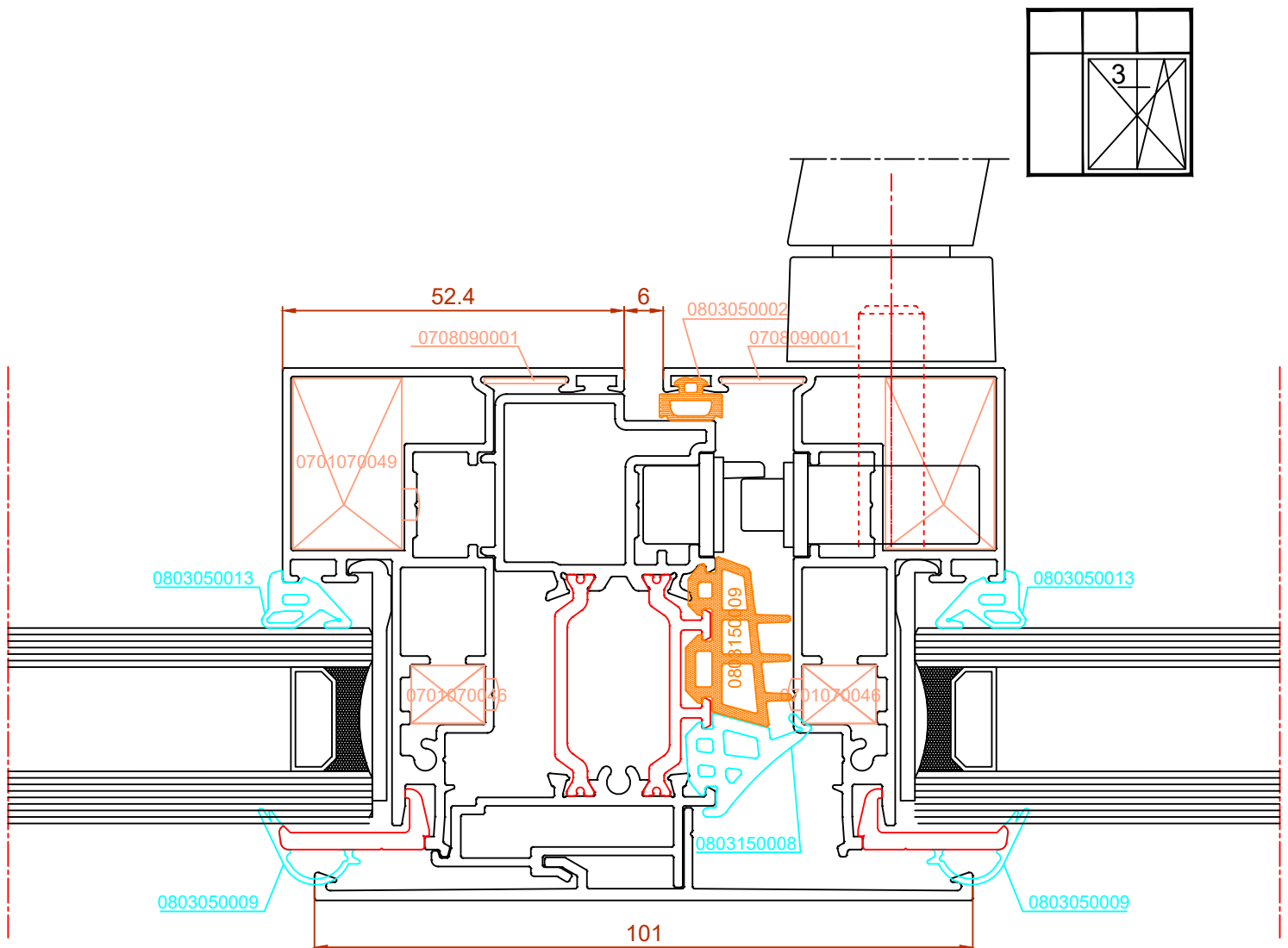

## Secciones tipo

RT74 H.O. C16 - G6

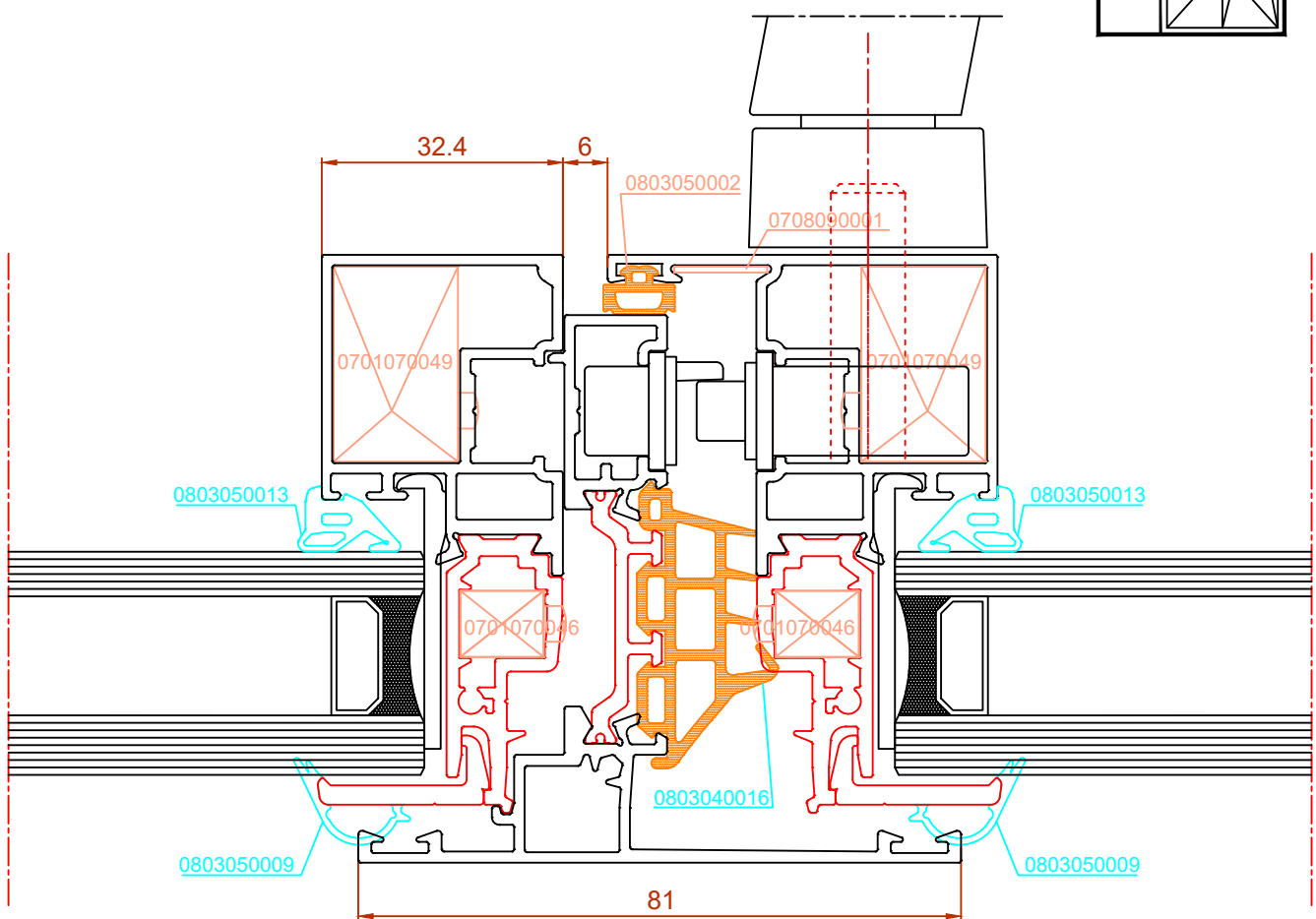
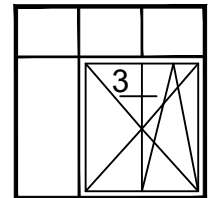

## Secciones tipo

vRT74 H.O. C16 - G7

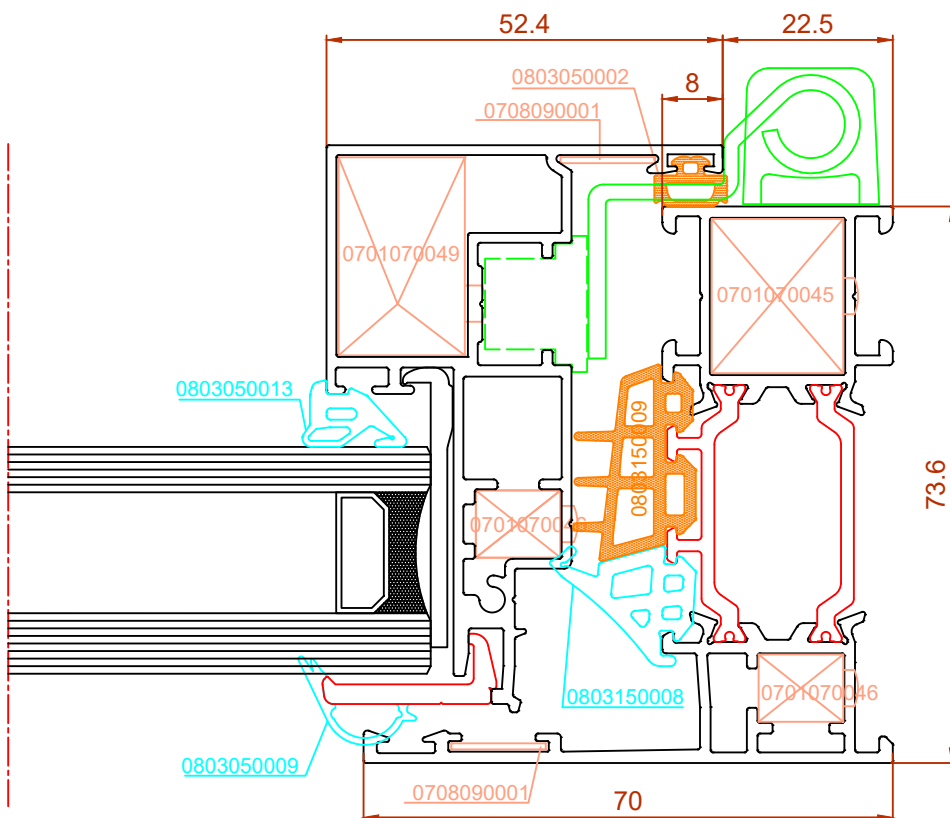
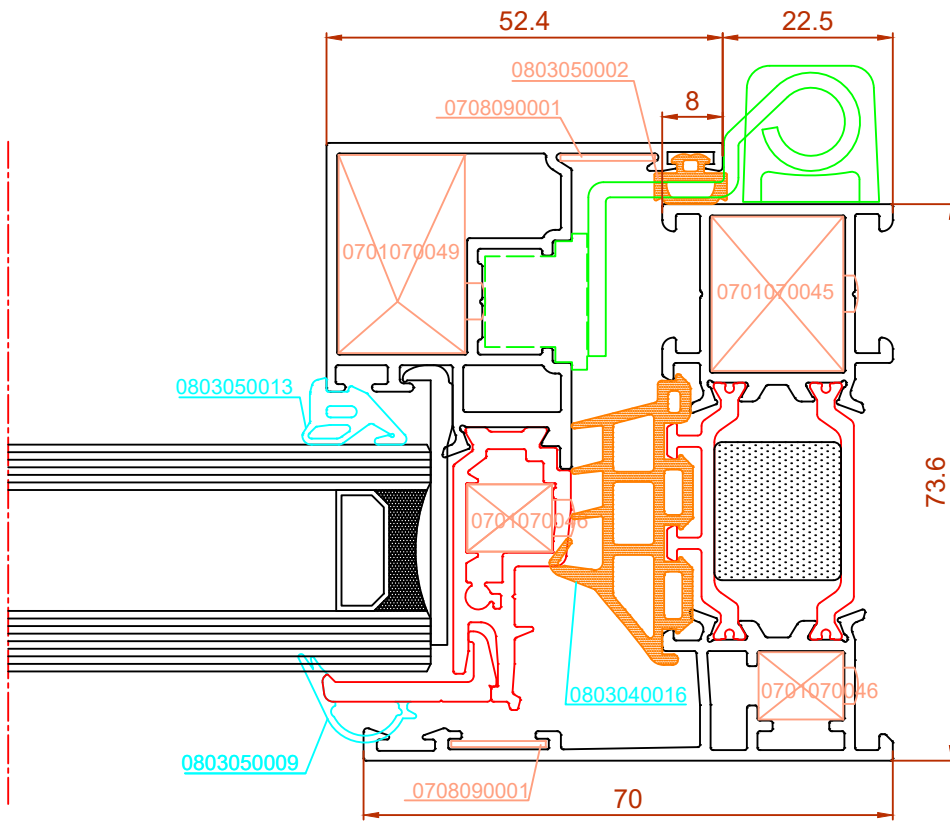

## Secciones tipo

RT74 H.O. C16 - G8

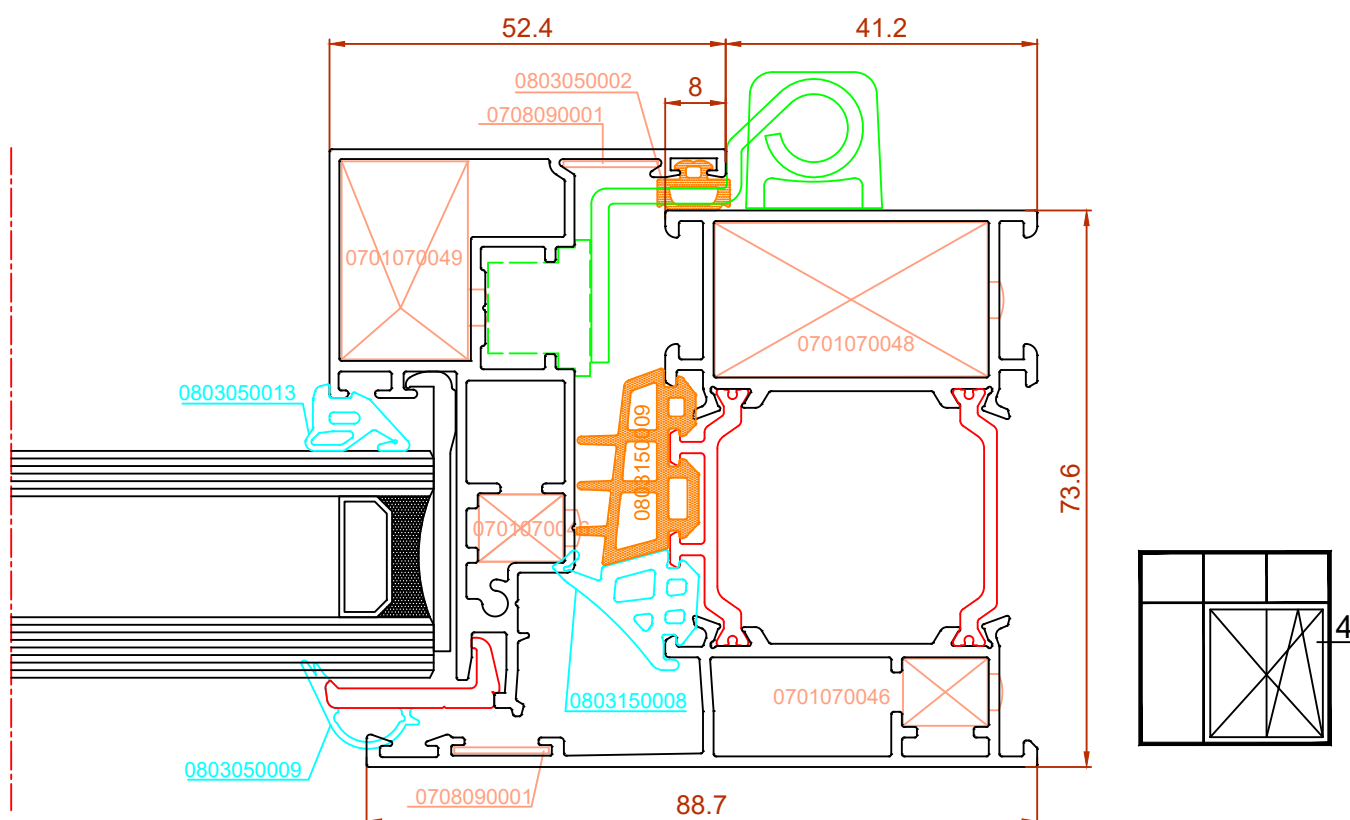
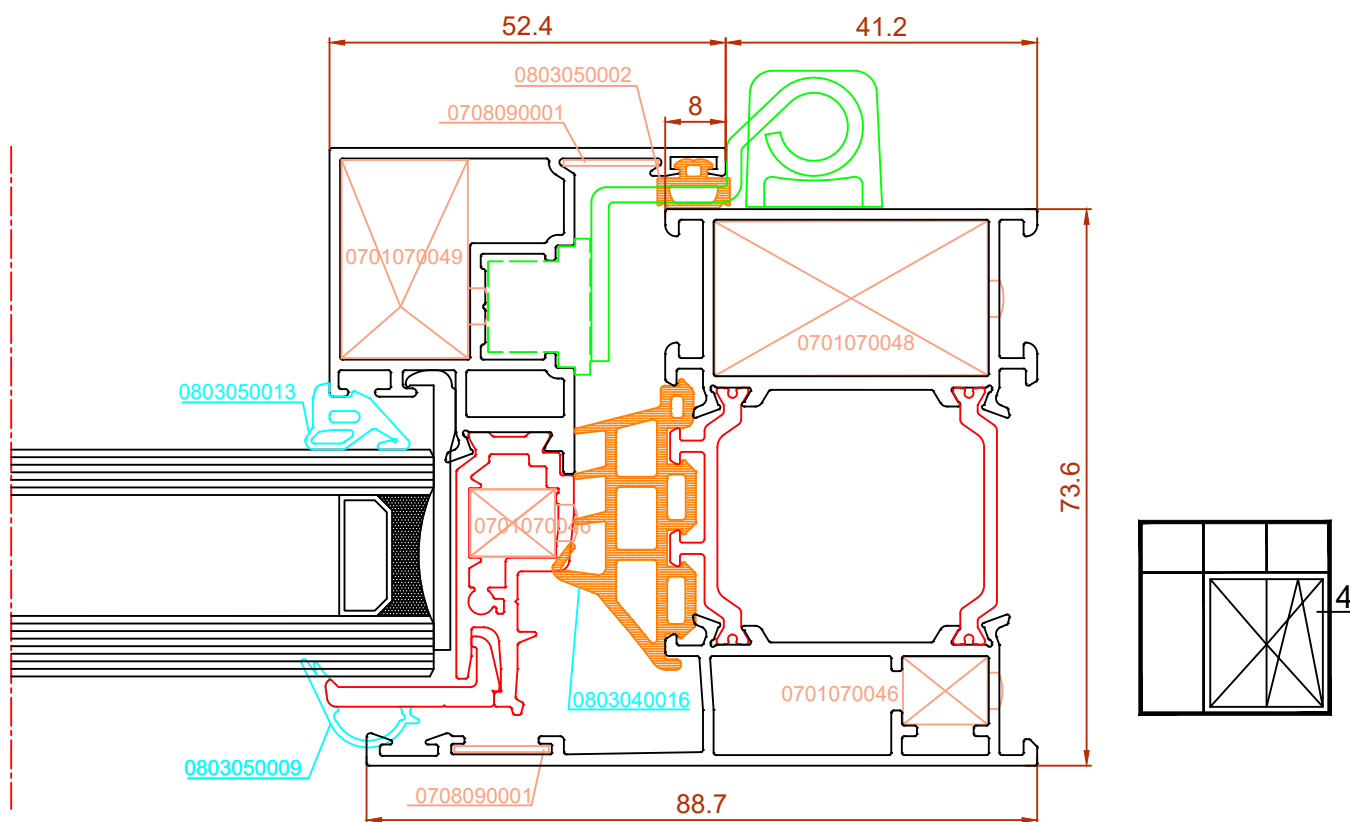

## Secciones tipo

RT74 H.O. C16 - G9

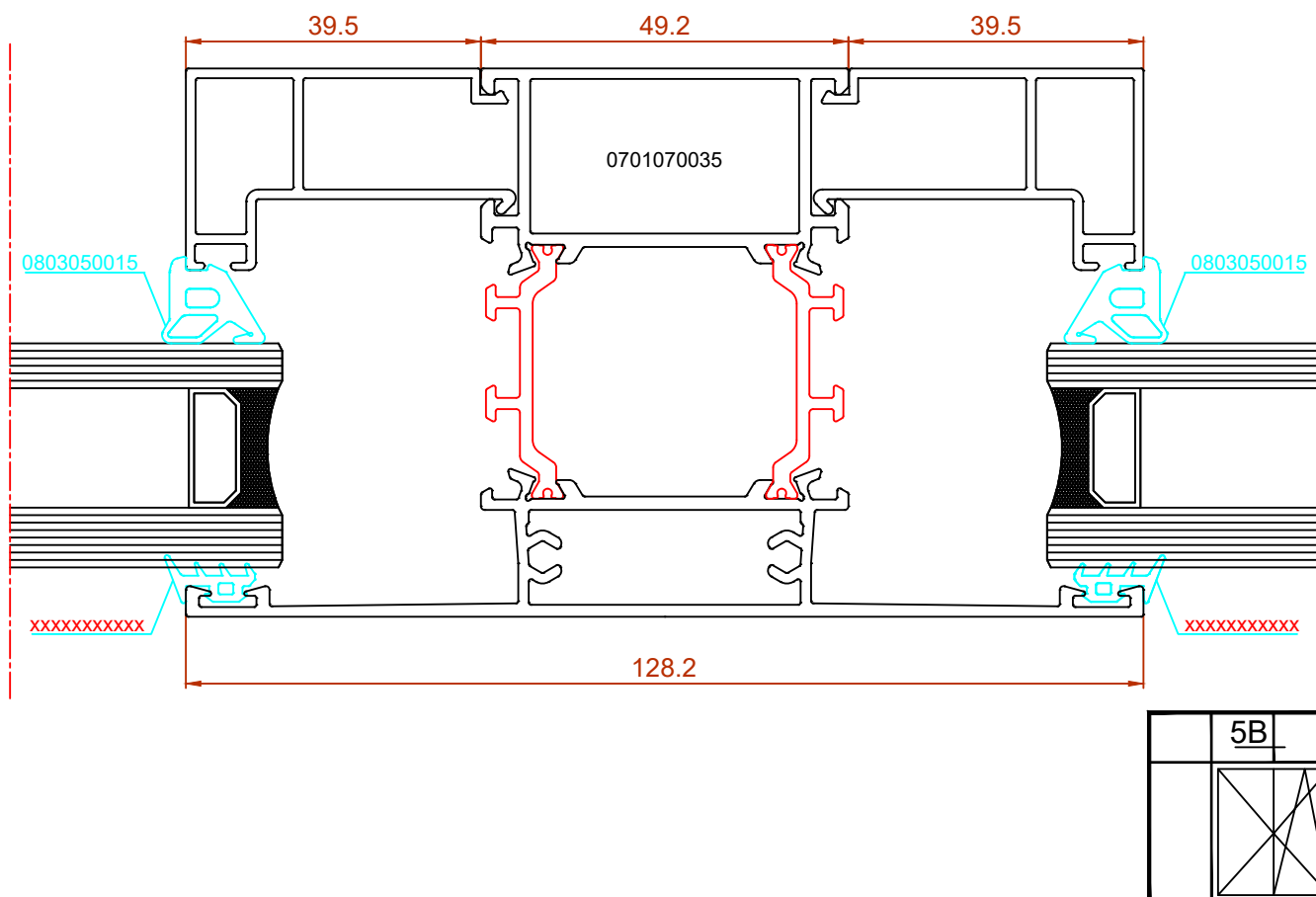
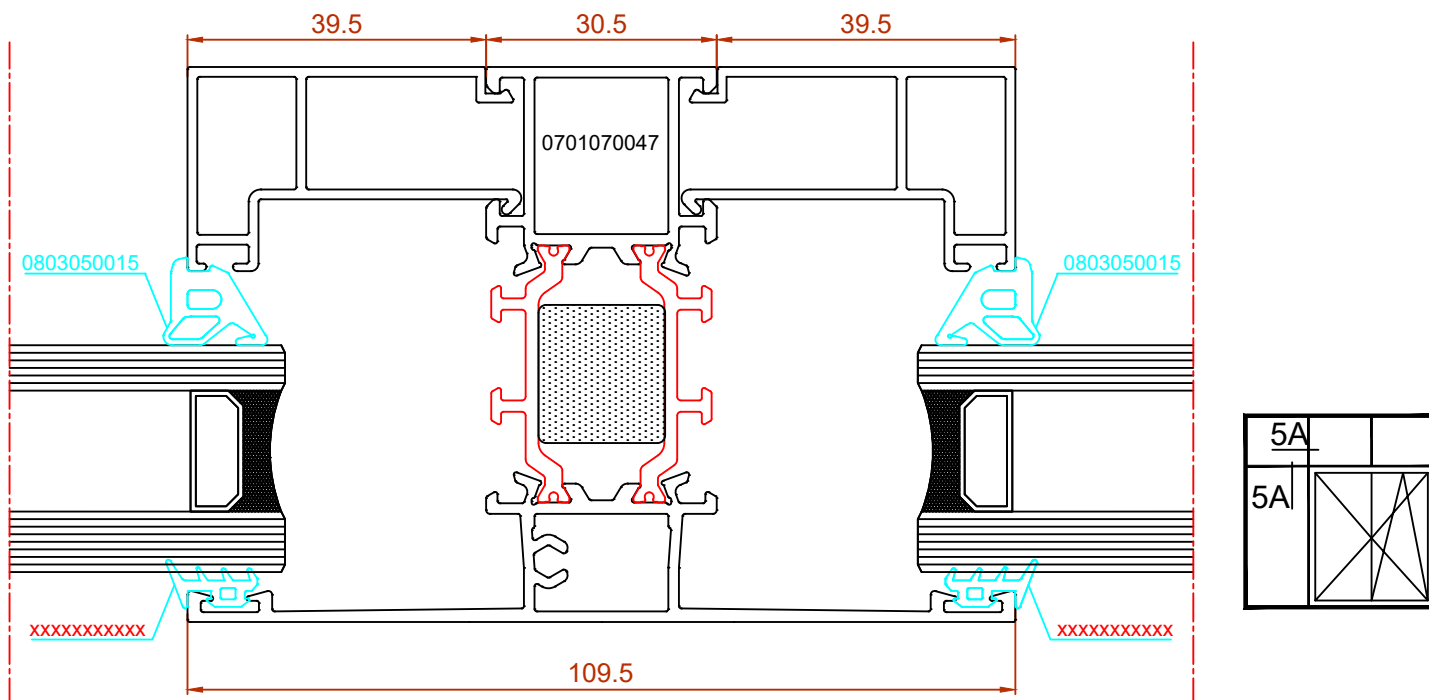

## Secciones tipo

RT74 H.O. C16 - G10

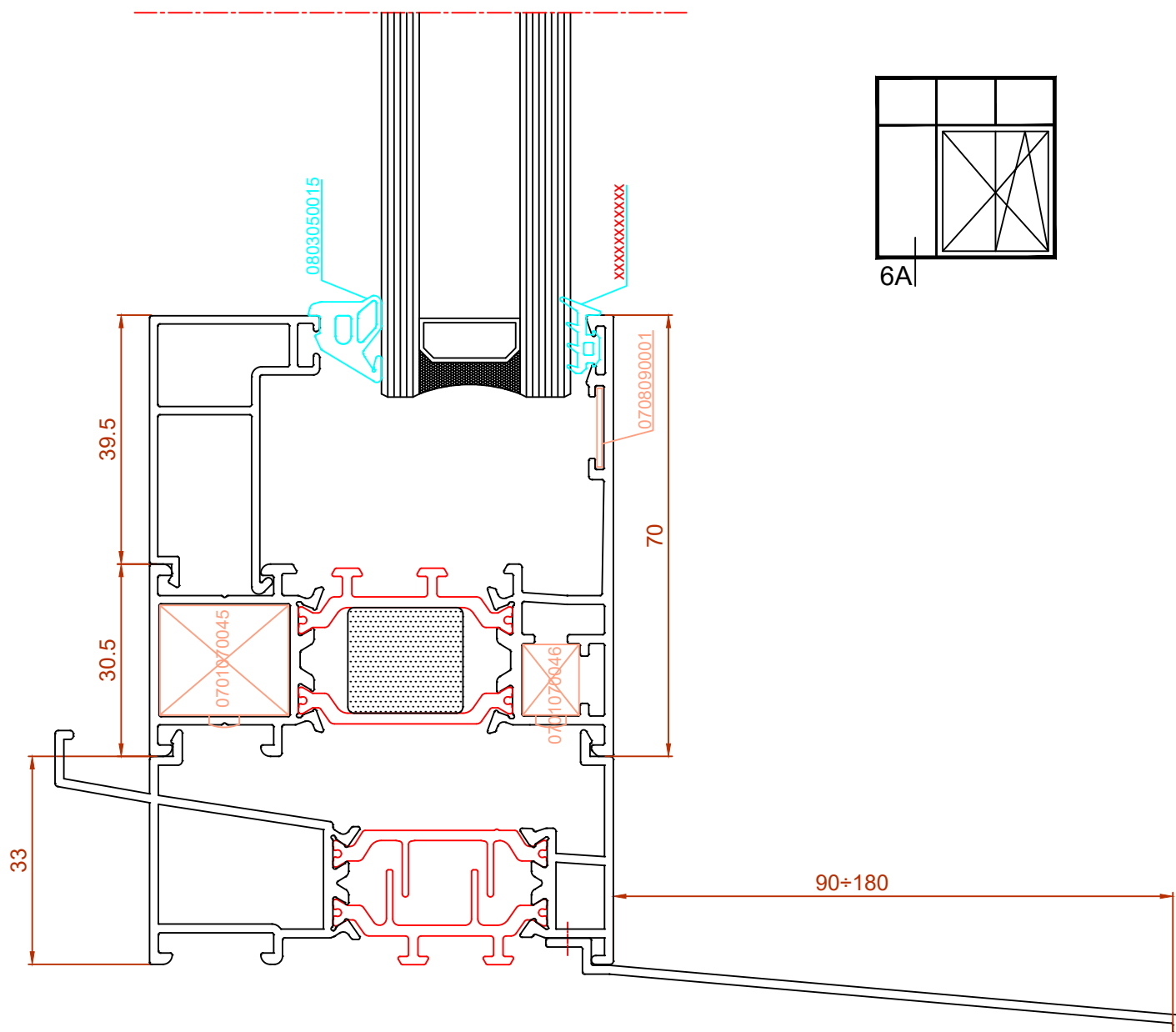



## Secciones tipo

RT74 H.O. C16 - G11

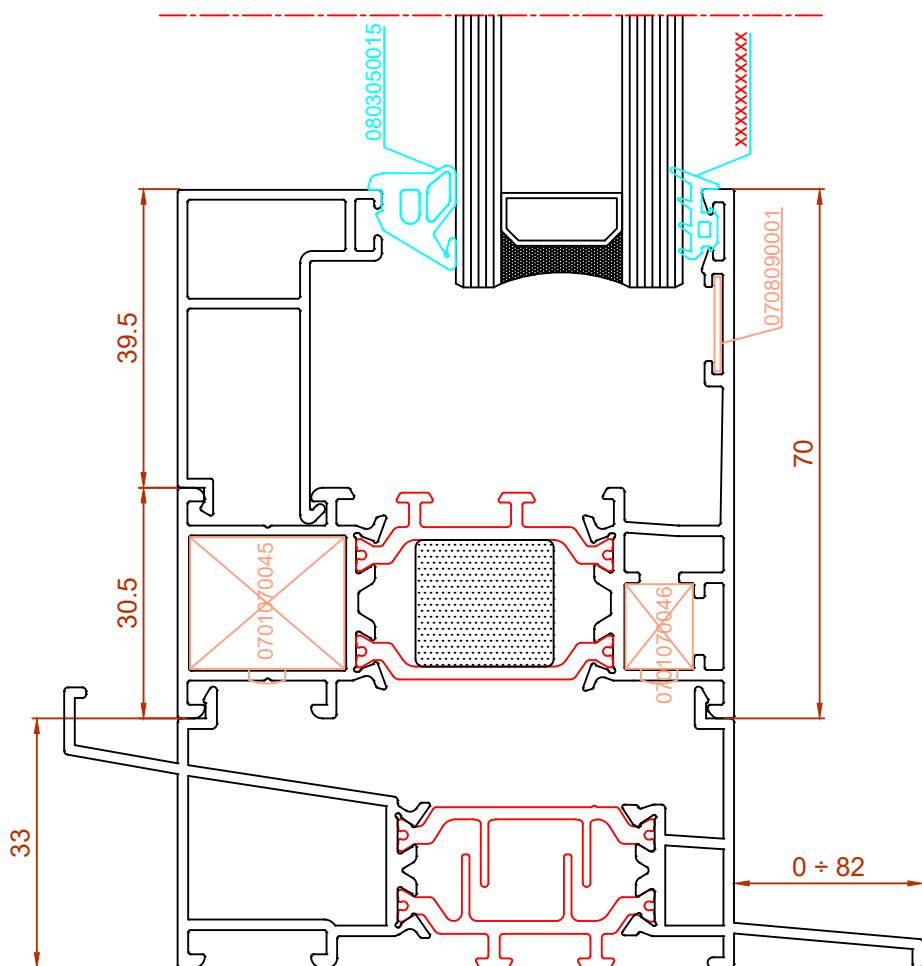
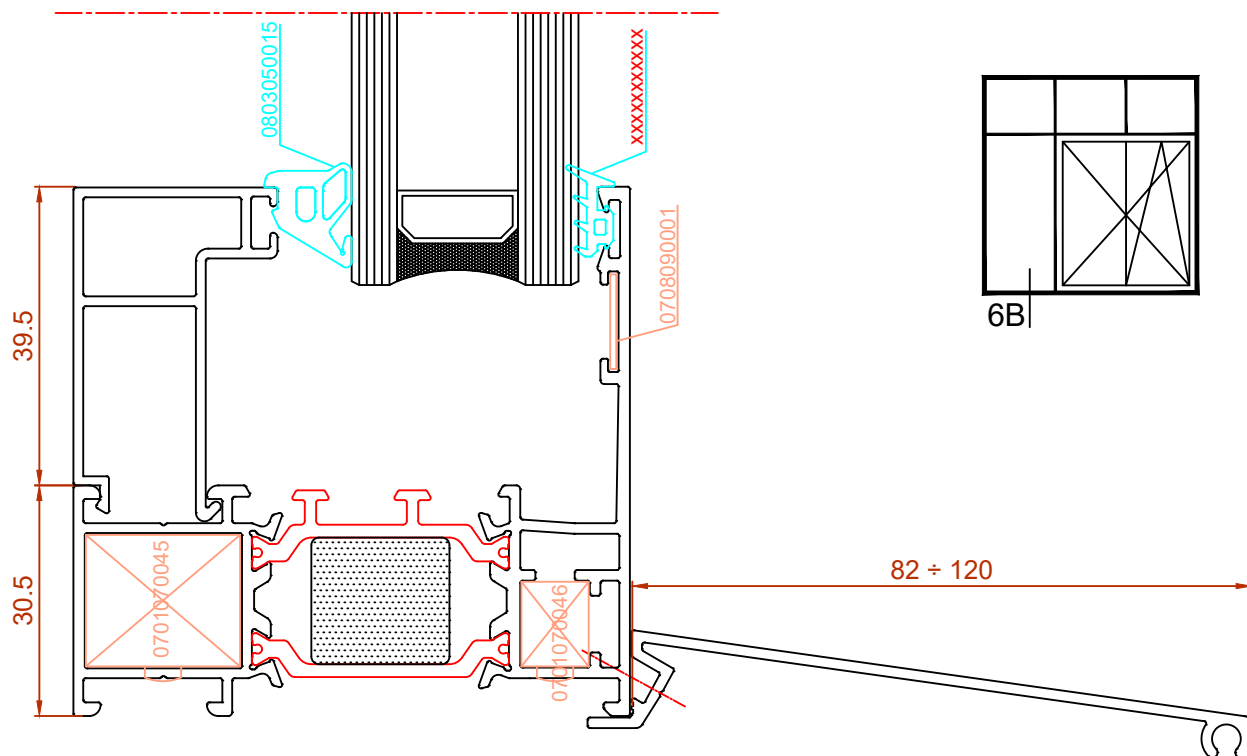

## Secciones tipo

RT74 H.O. C16 - G12

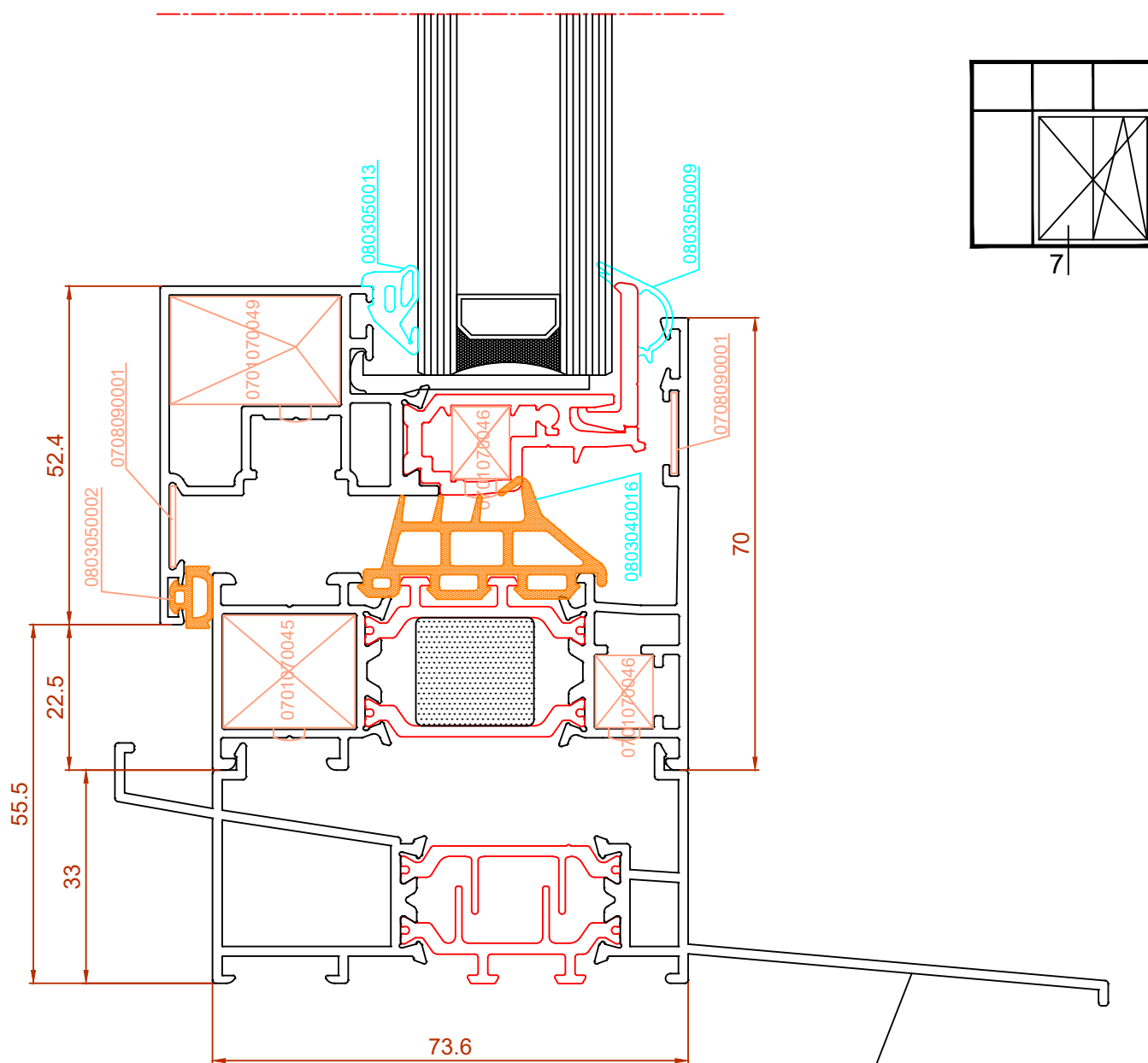

Ver alternativas en Secciones 6A, 6B, 6C

## Secciones tipo

RT74 H.O. C16 - G13

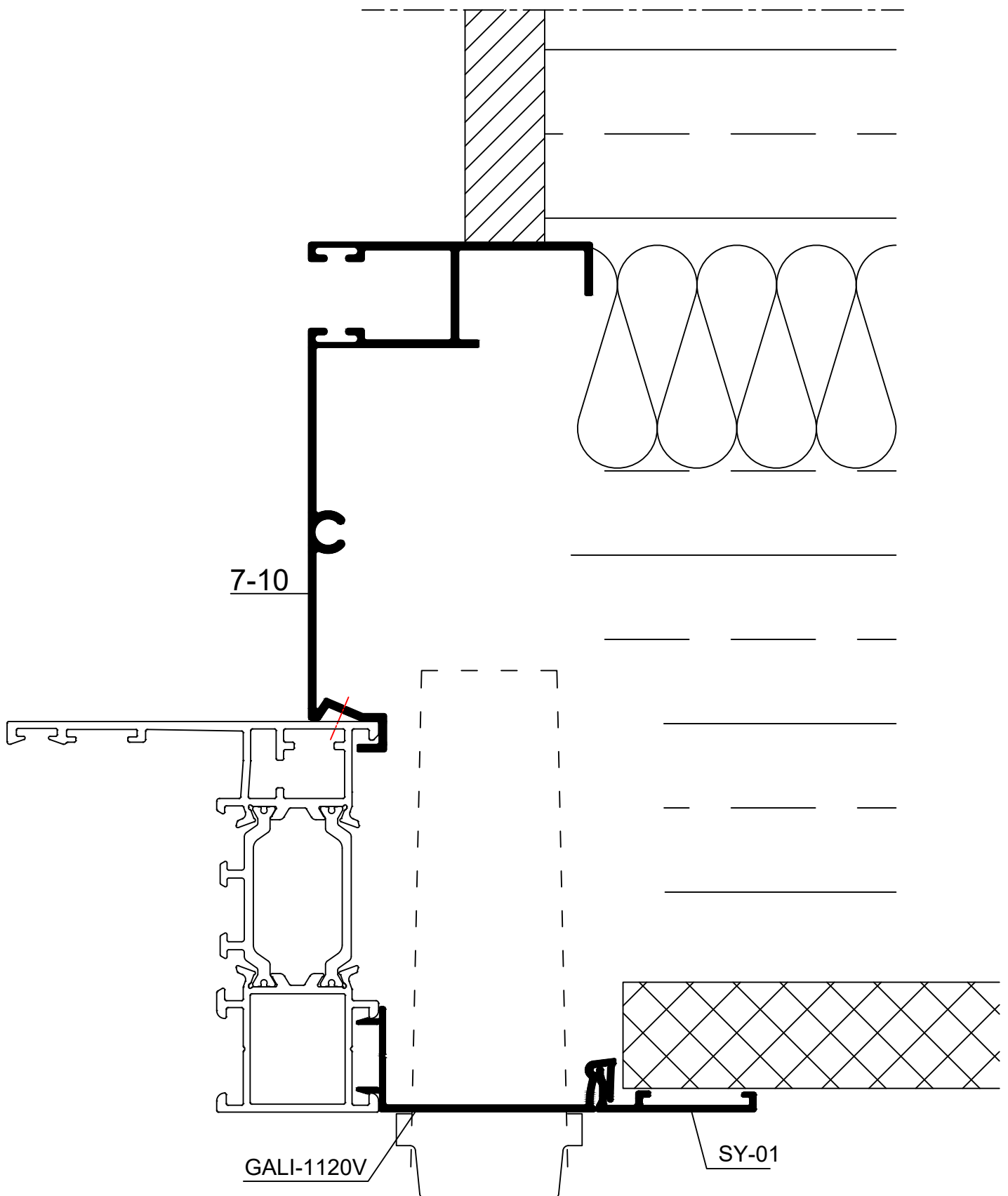

## Secciones tipo

RT74 H.O. C16 - G14

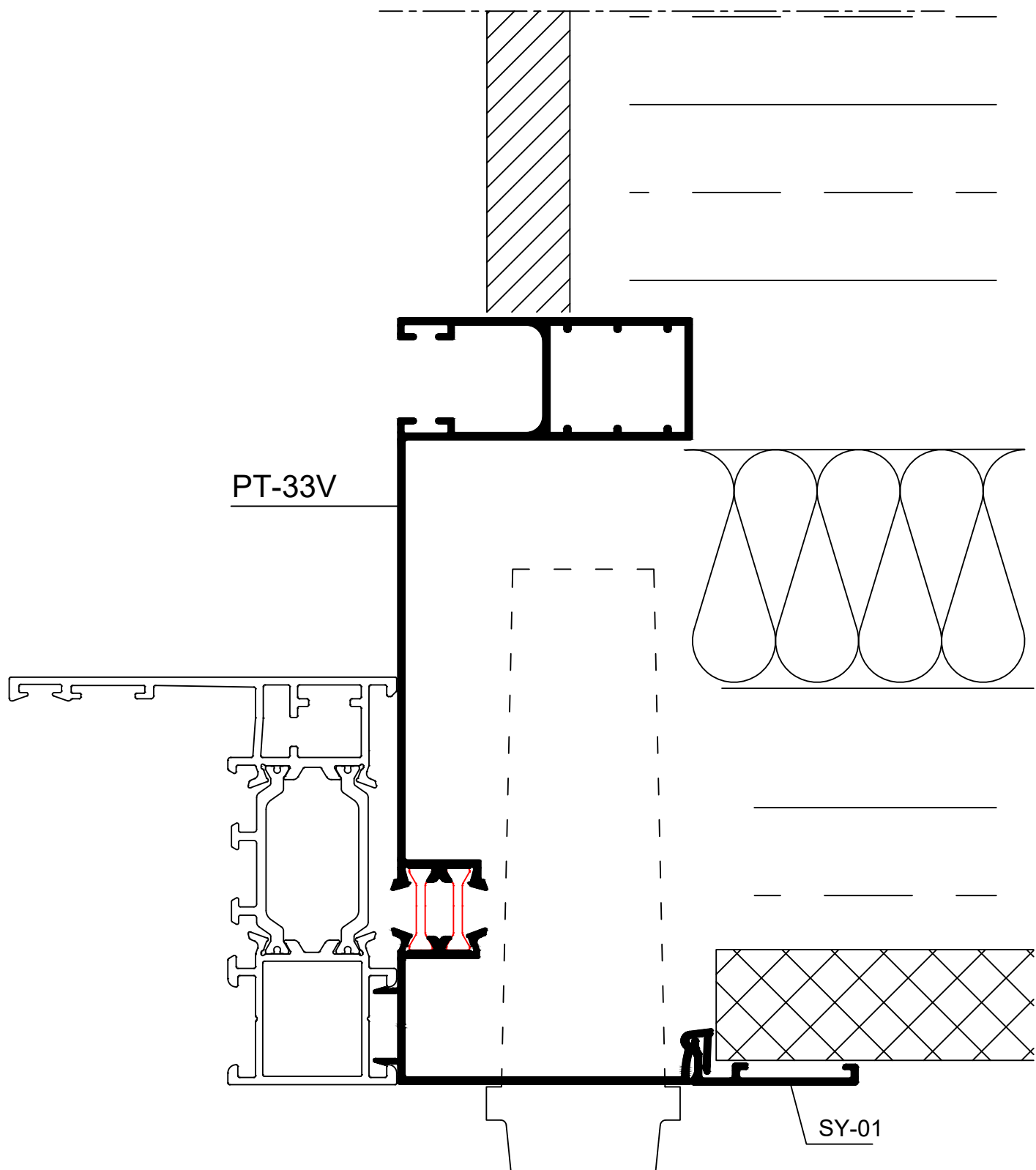

## Secciones tipo

RT74 H.O. C16 - G15

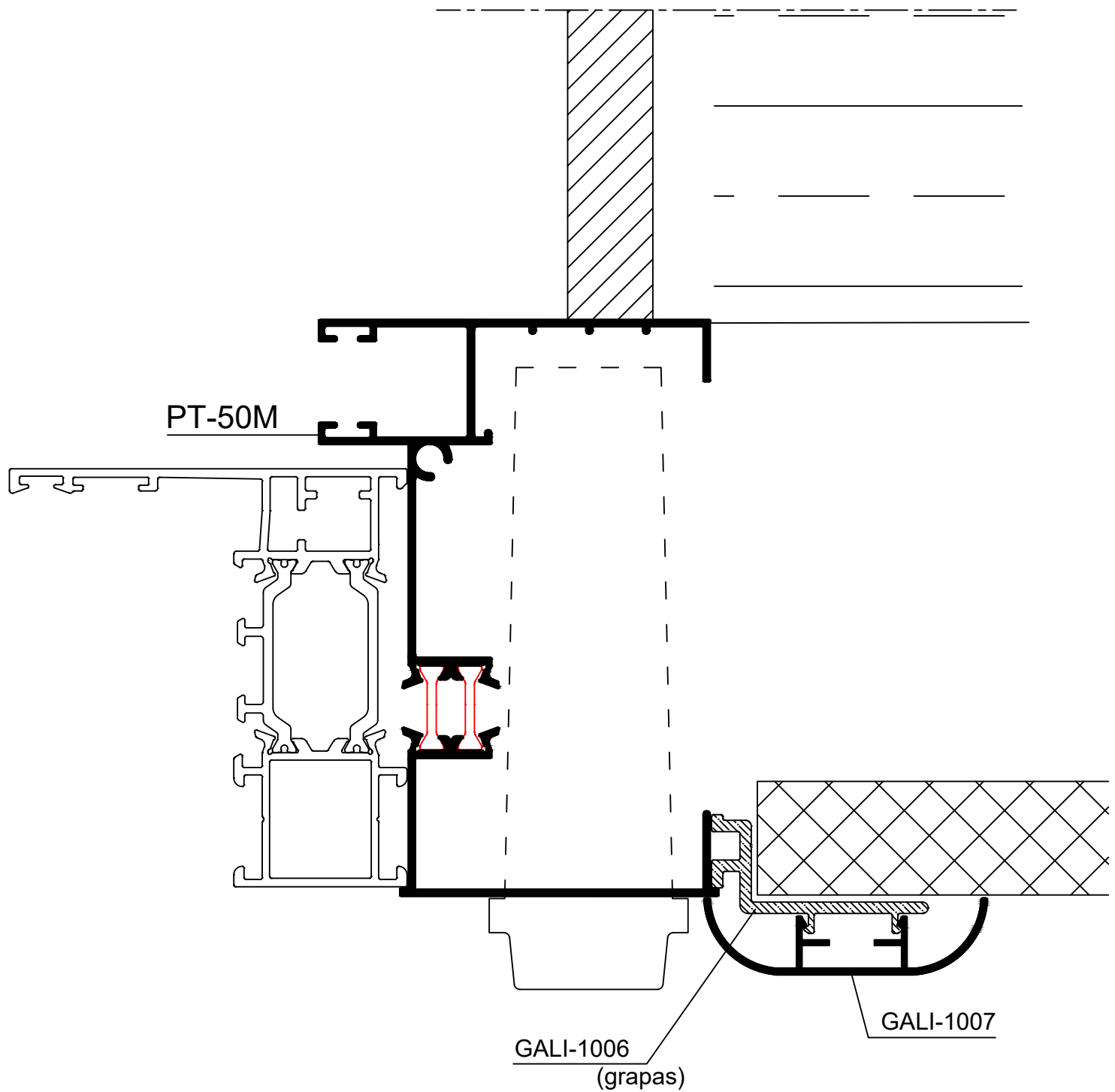

## Secciones tipo

RT74 H.O. C16 - G16

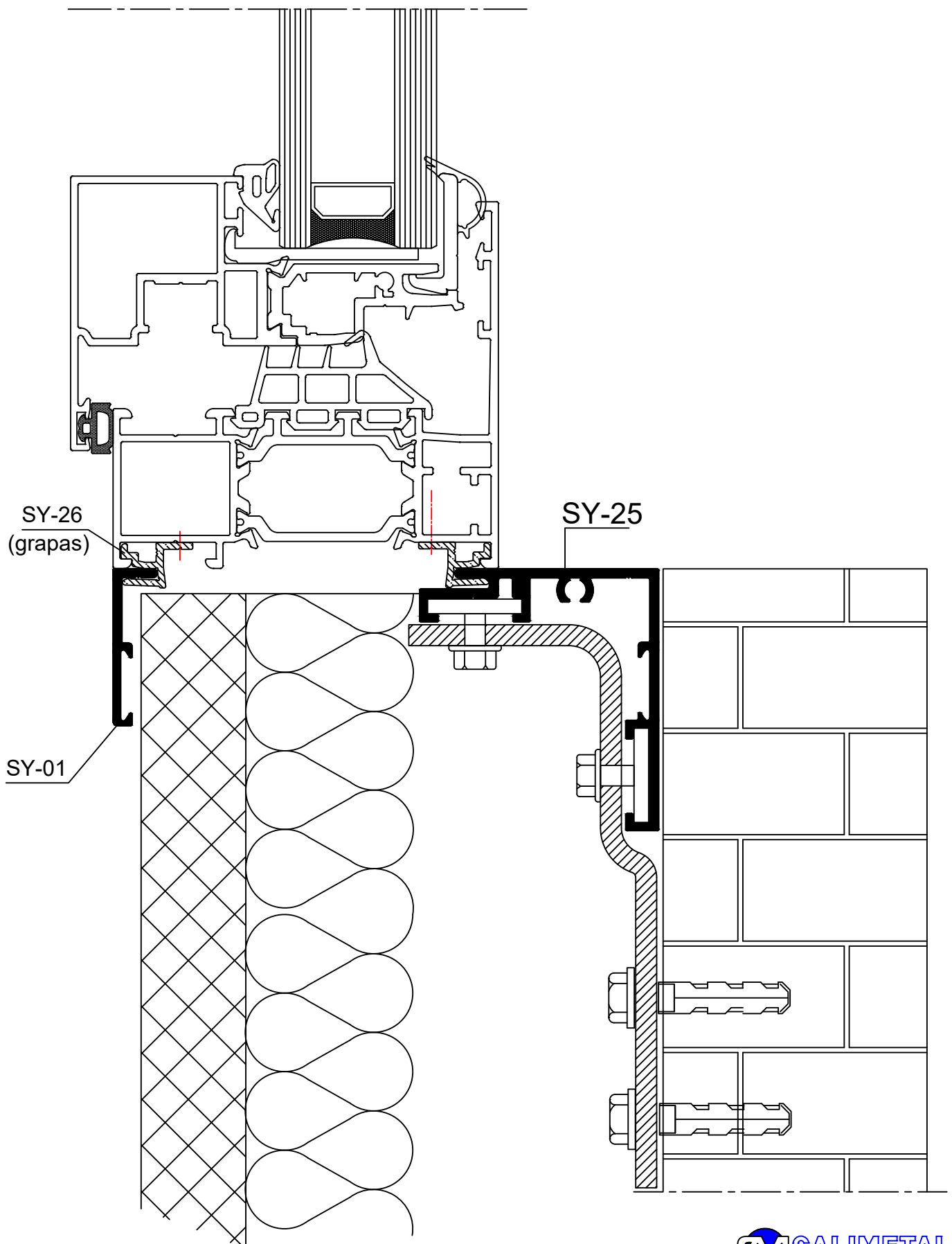

## Secciones tipo

RT74 H.O. C16 - G17

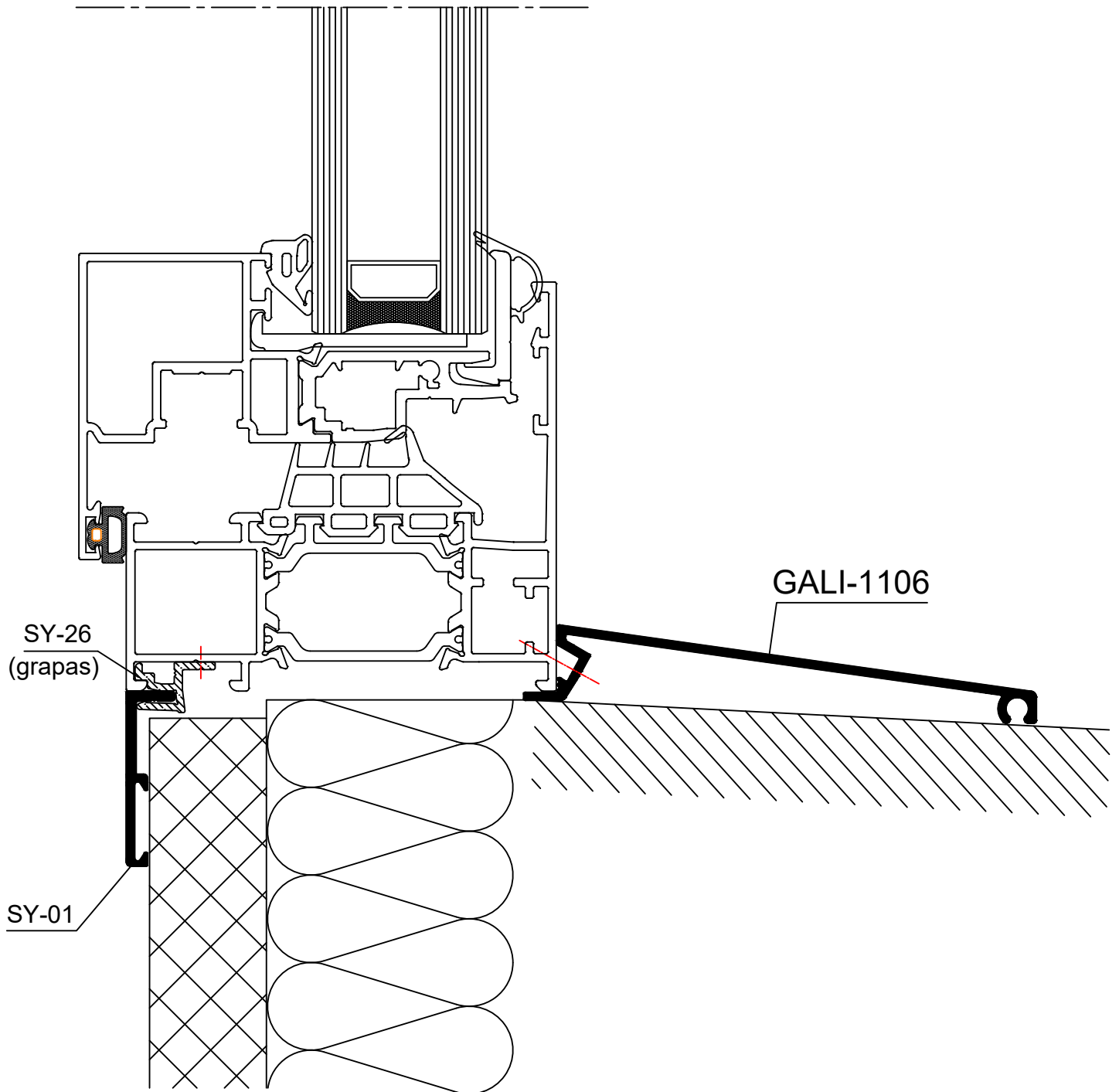

## Secciones tipo

RT74 H.O. C16 - G18

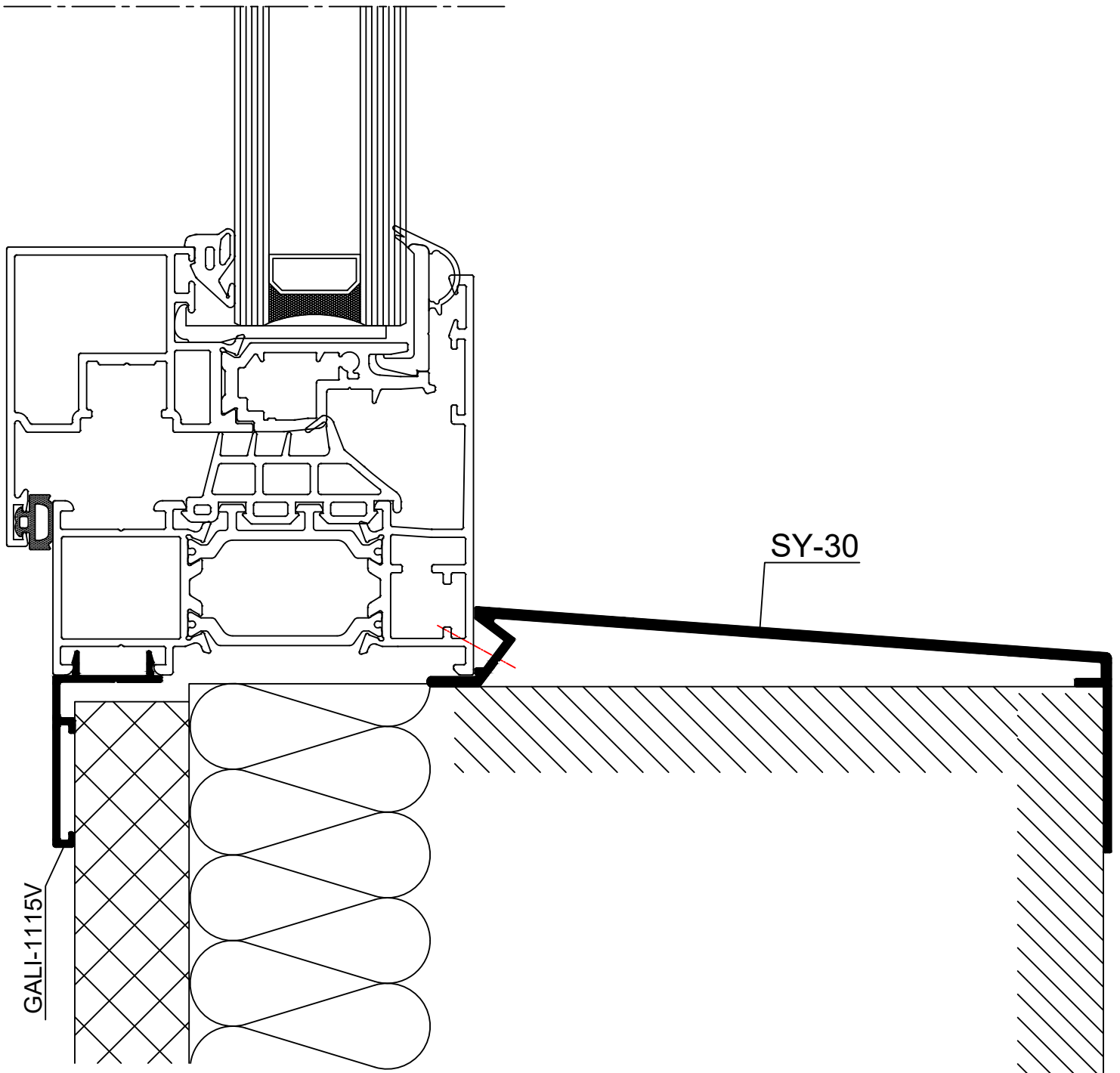



## Secciones tipo

RT74 H.O. C16 - G19

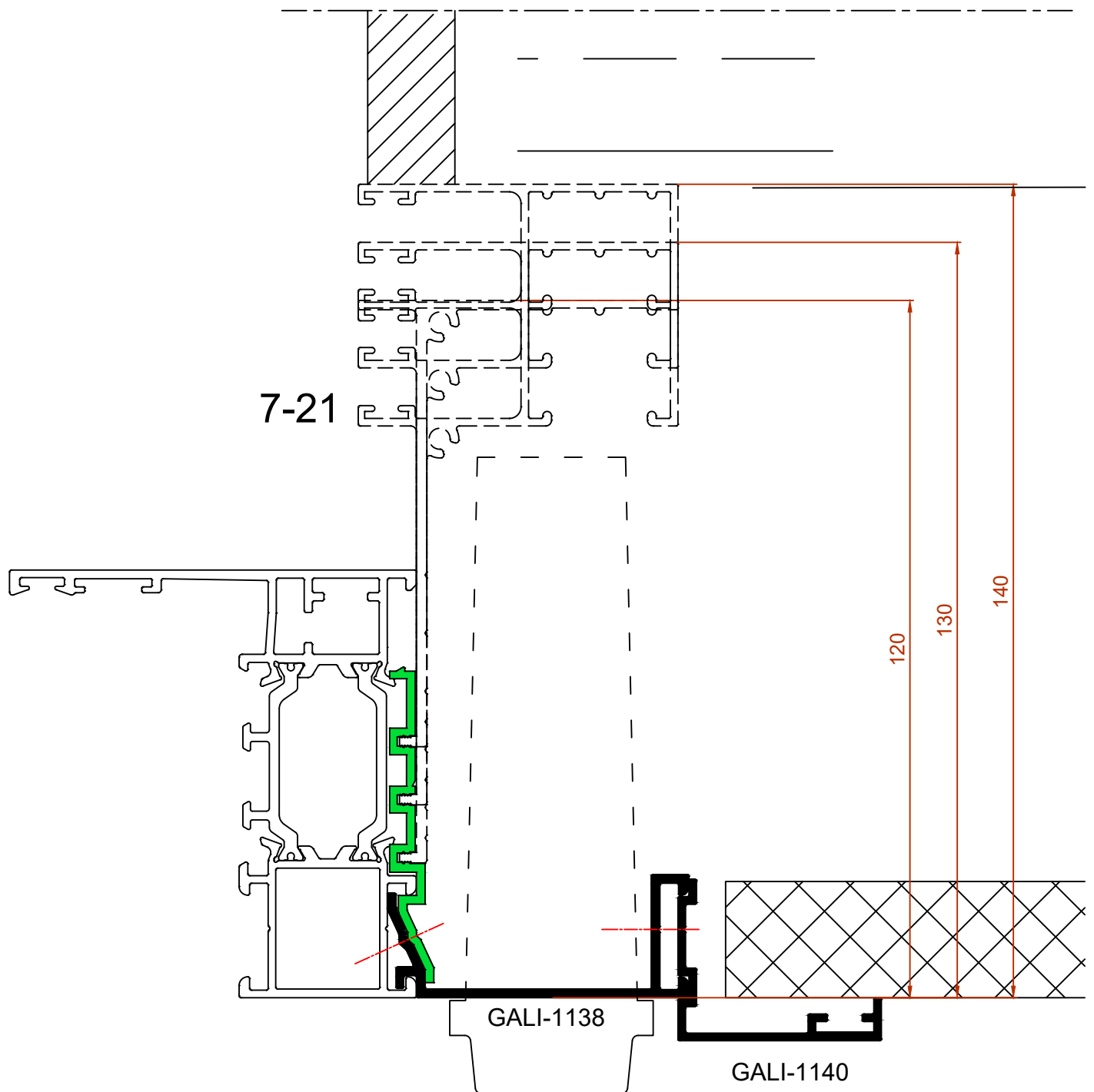

## Secciones tipo

RT74 H.O. C16 - G20

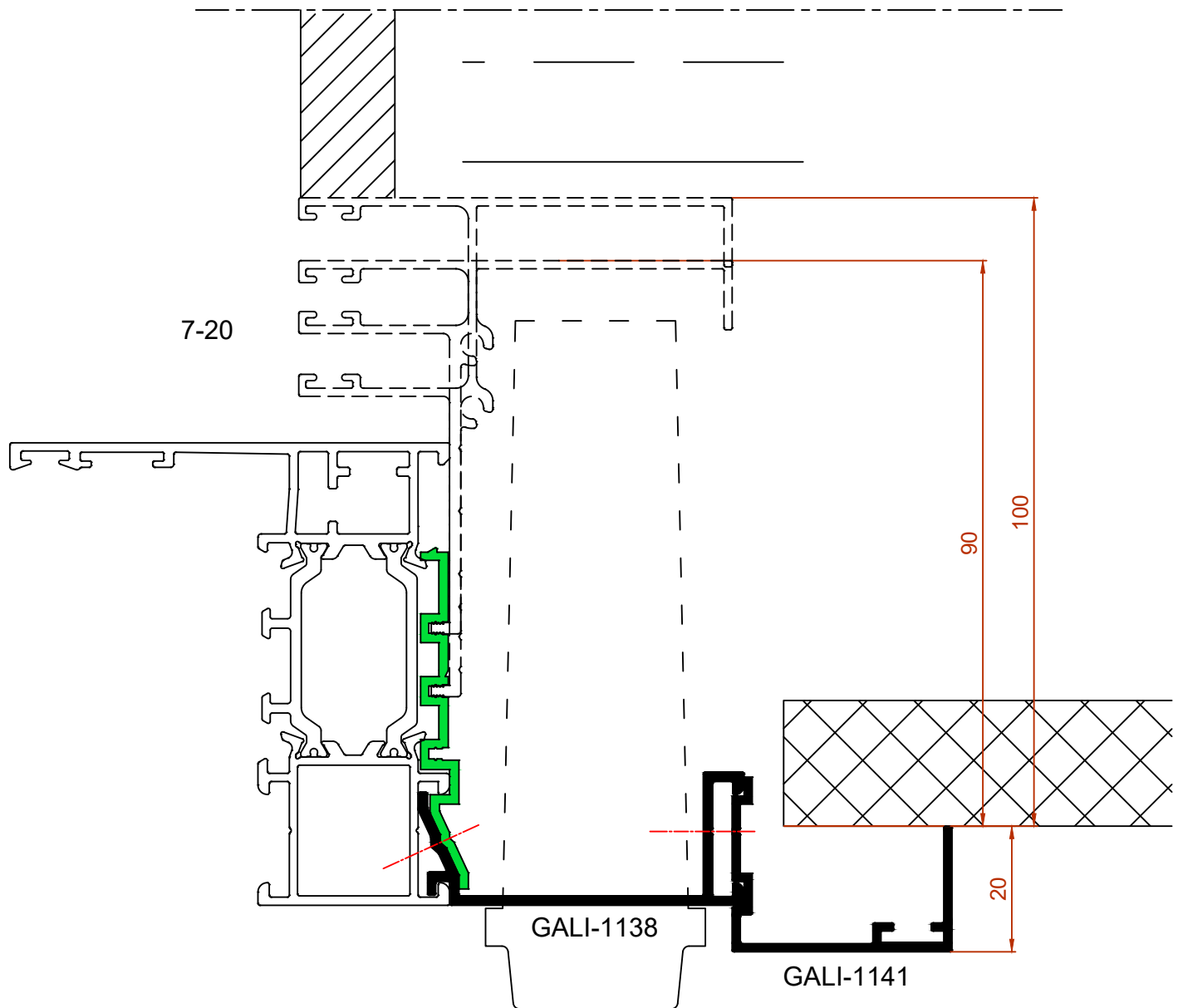

## Secciones tipo

RT74 H.O. C16 -G21

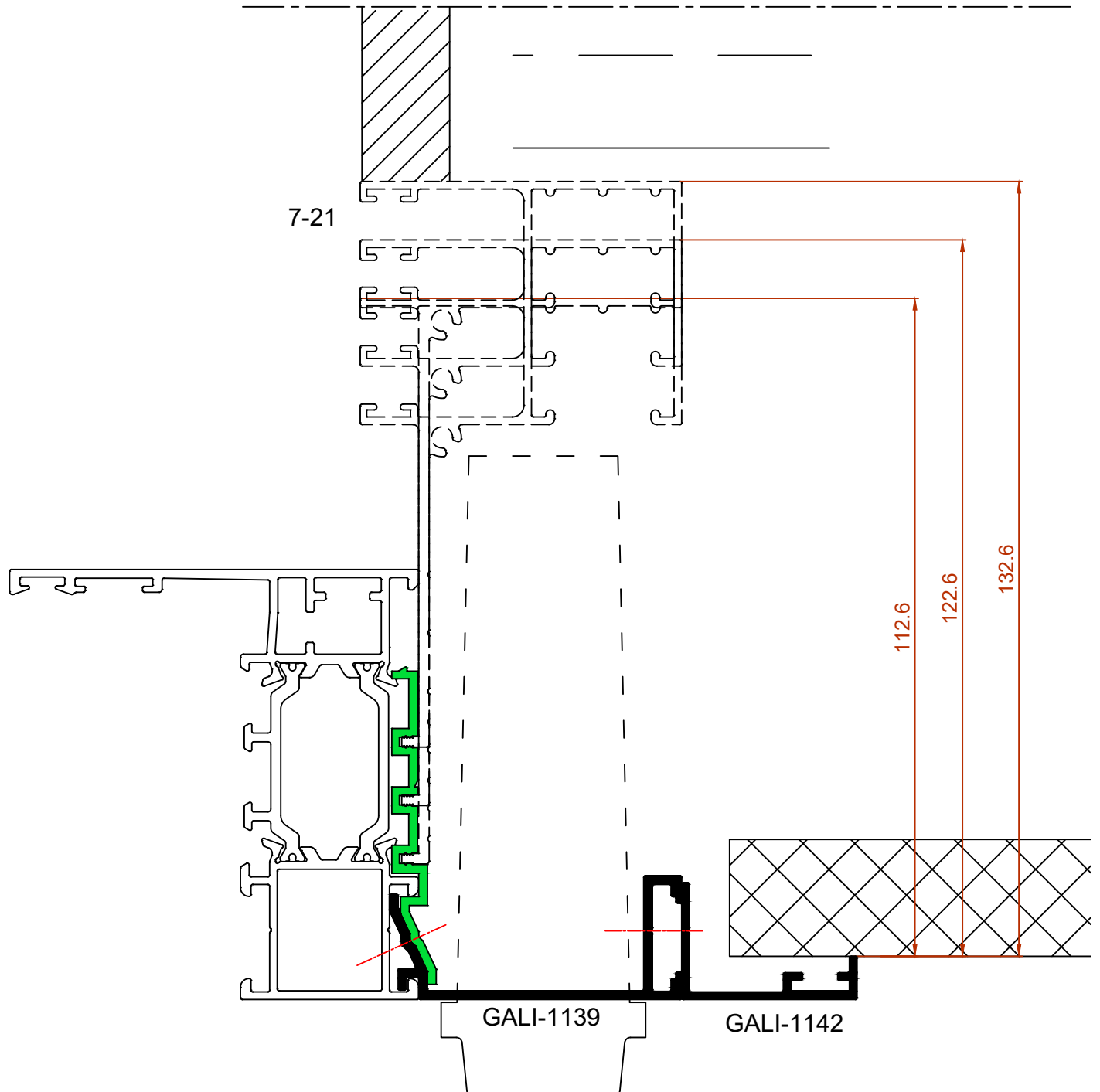

## Secciones tipo

RT74 H.O. C16 - G22

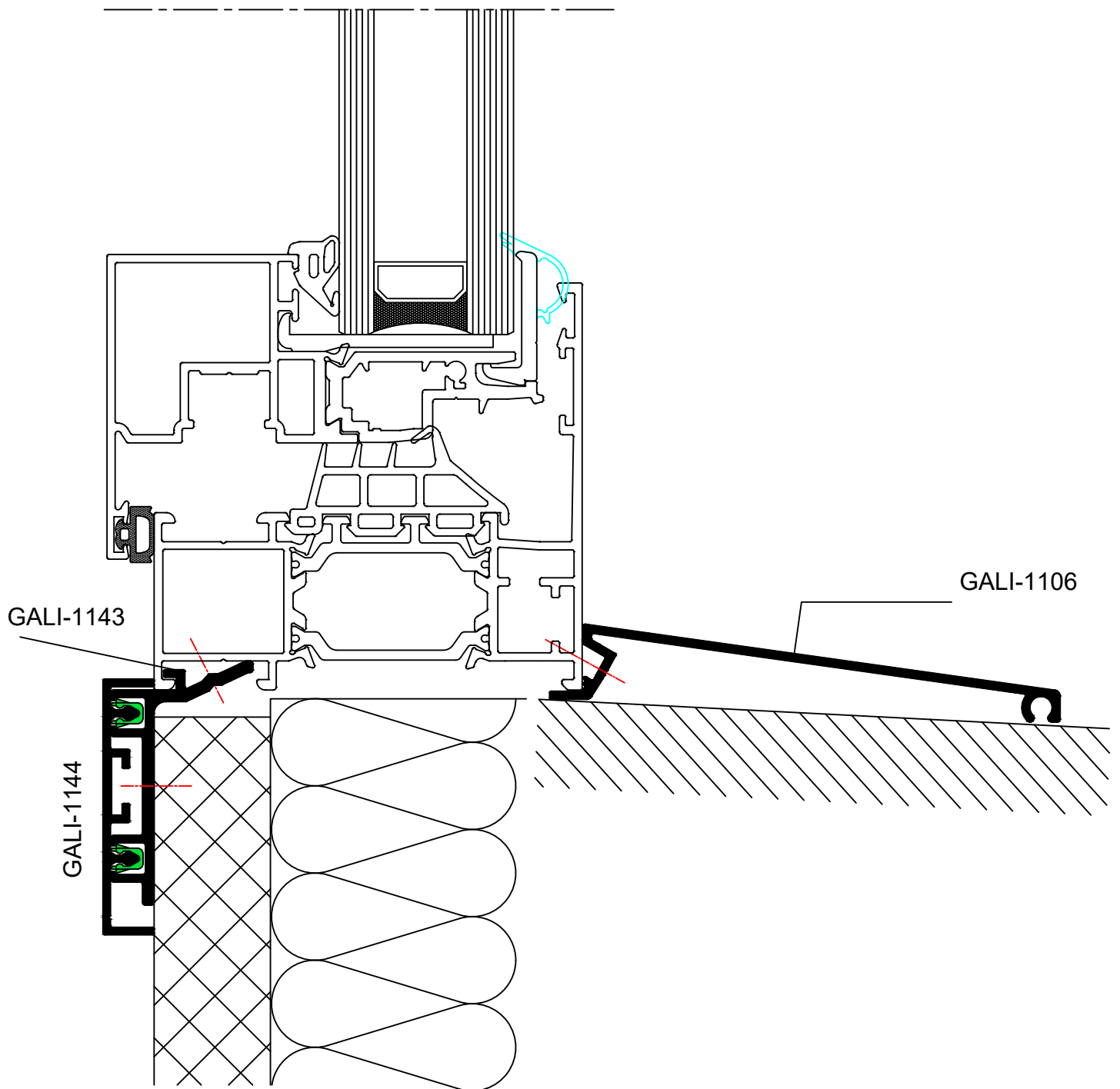

## Secciones tipo

RT74 H.O. C16 - G23

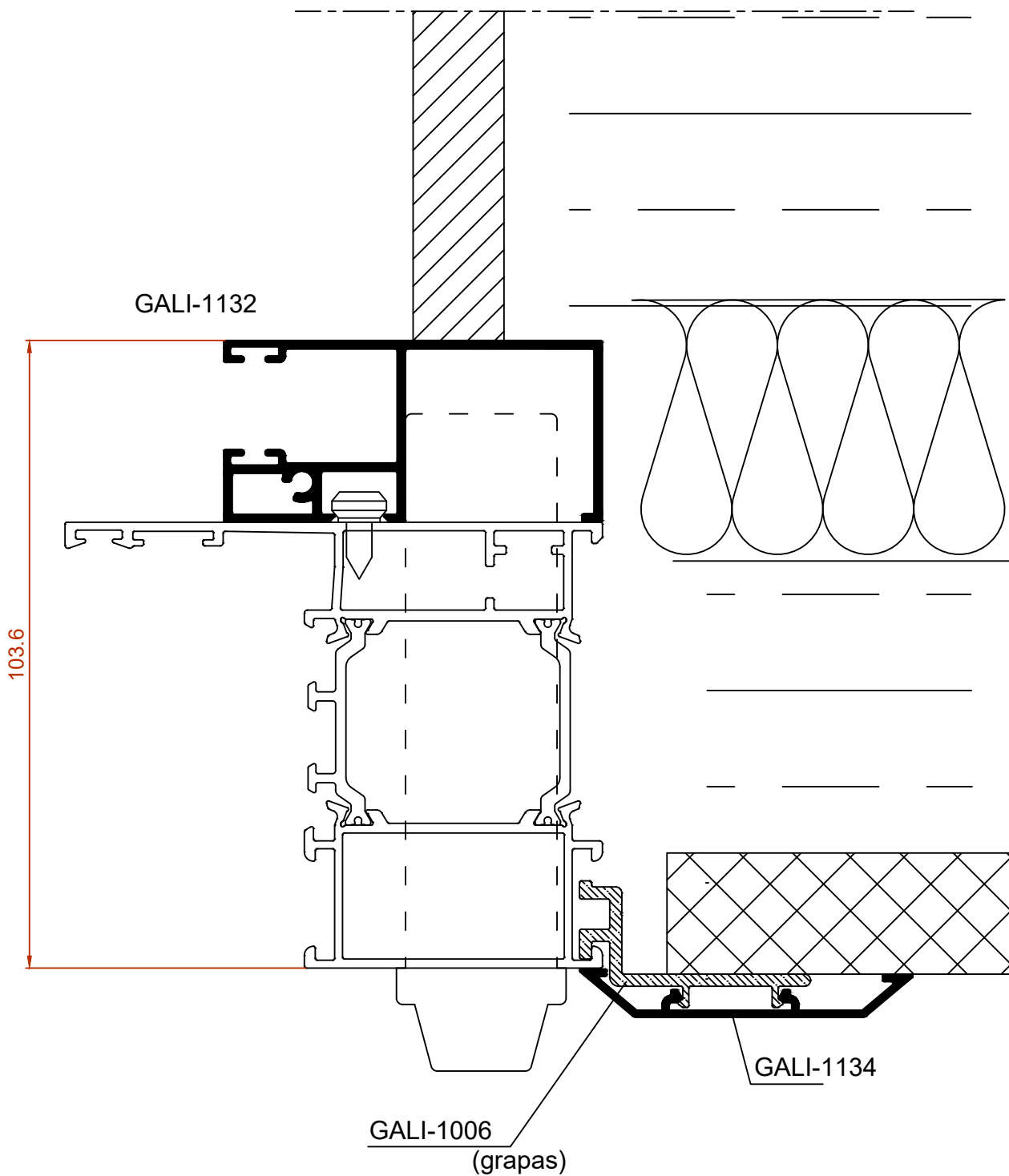

## Secciones tipo

RT74 H.O. C16 - G24

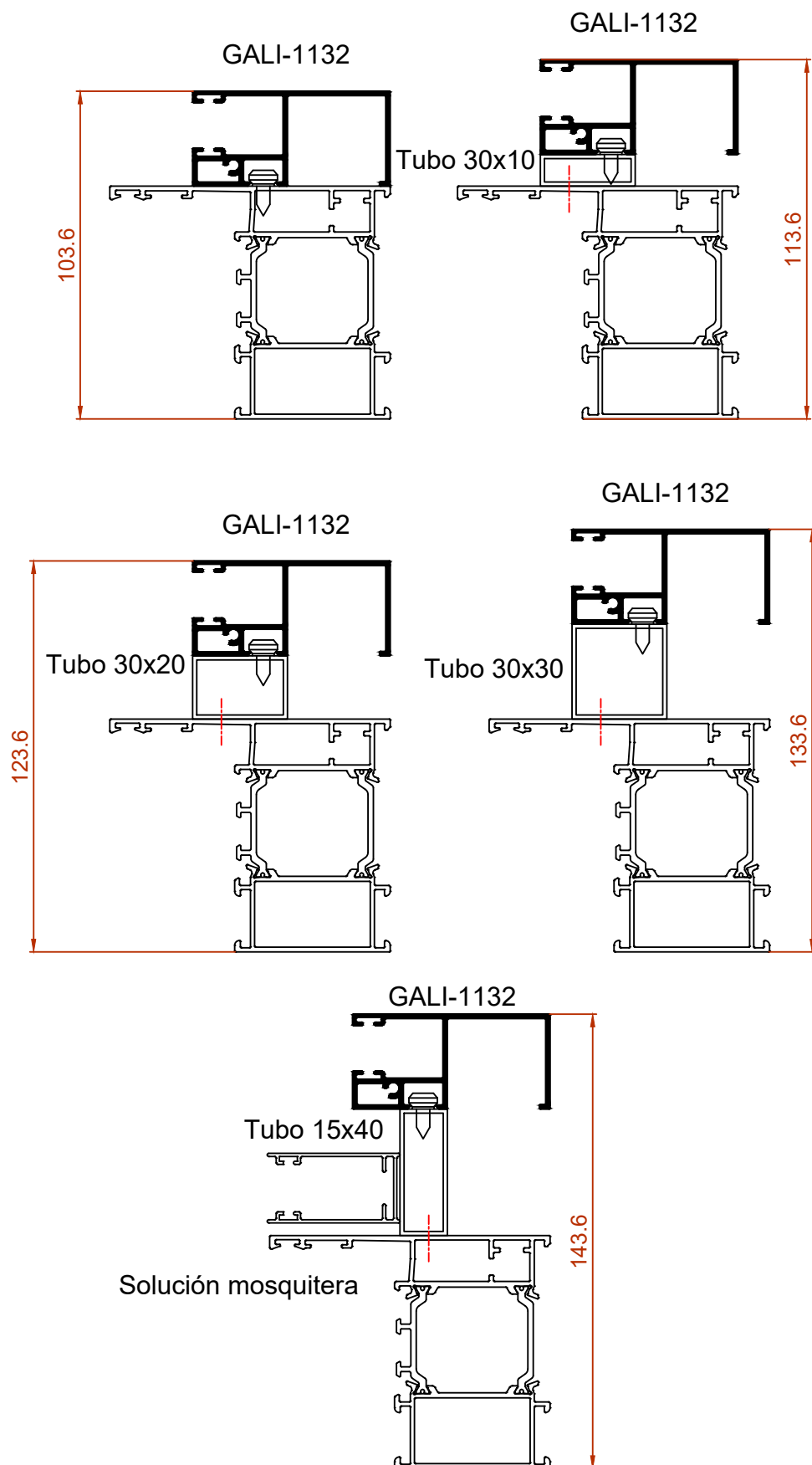

## Secciones tipo

RT74 H.O. C16 - G25

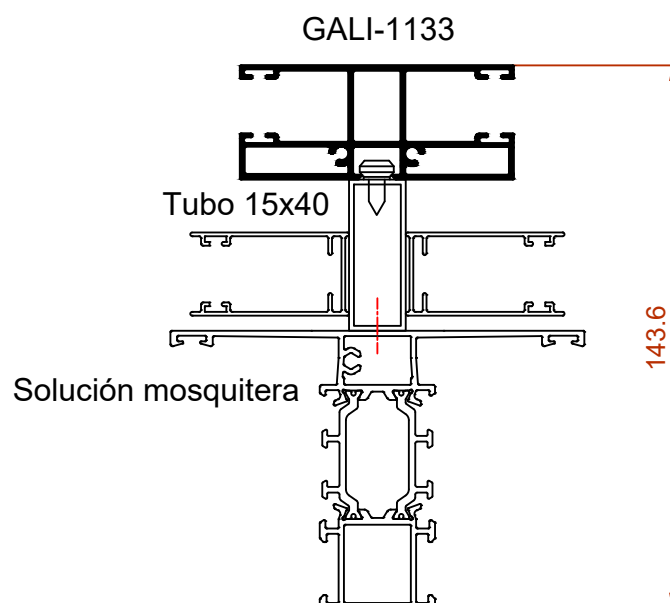
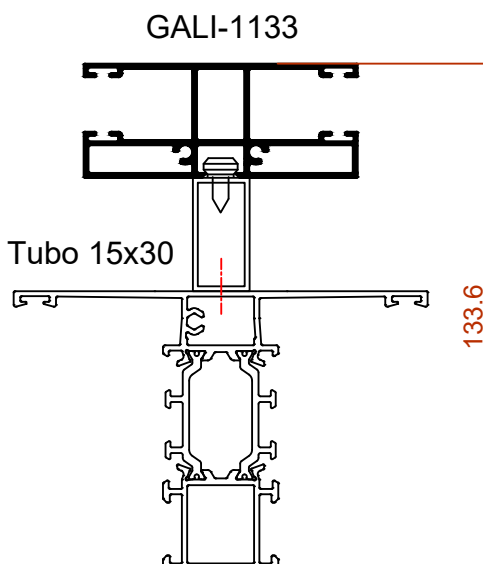
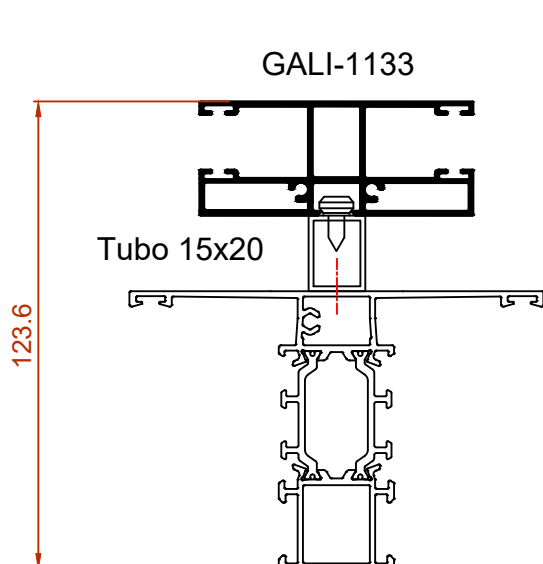
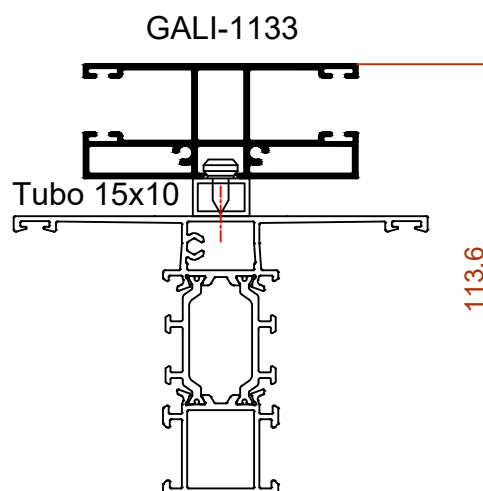
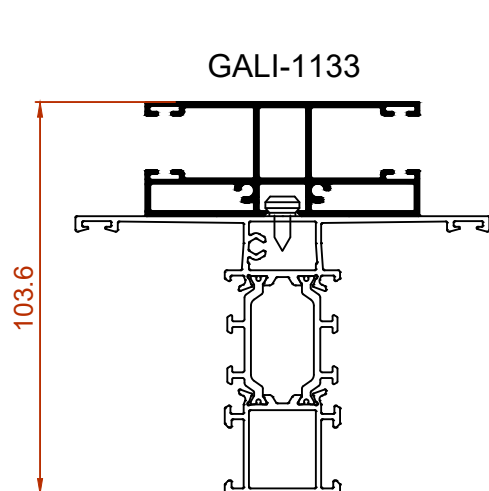

## Secciones tipo

RT74 H.O. C16 - G26

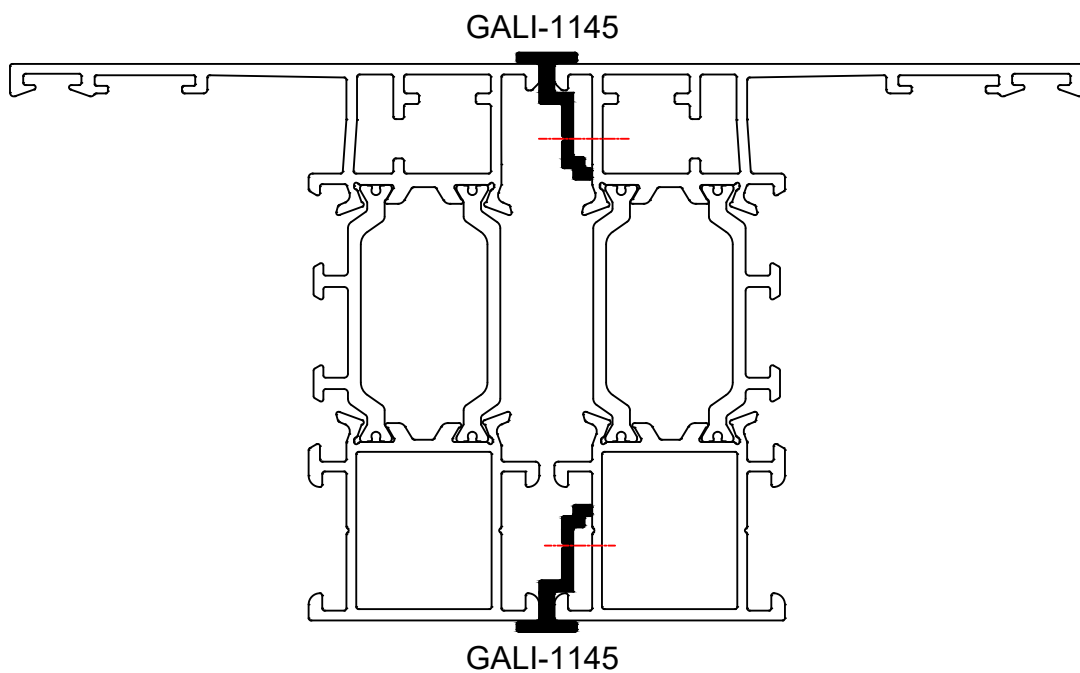
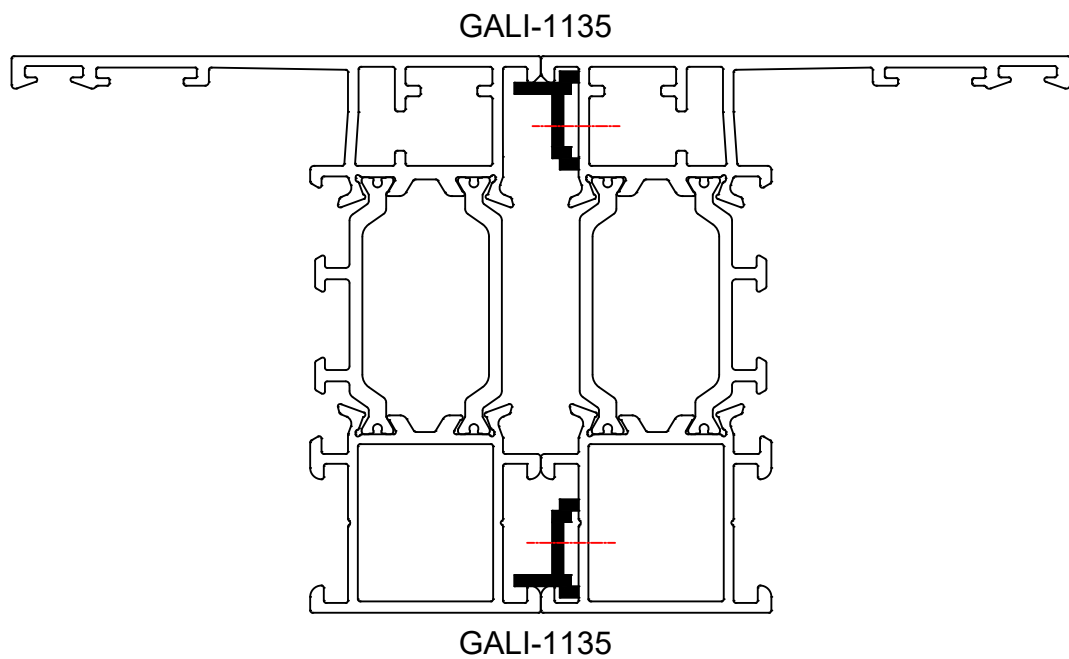



## Secciones tipo



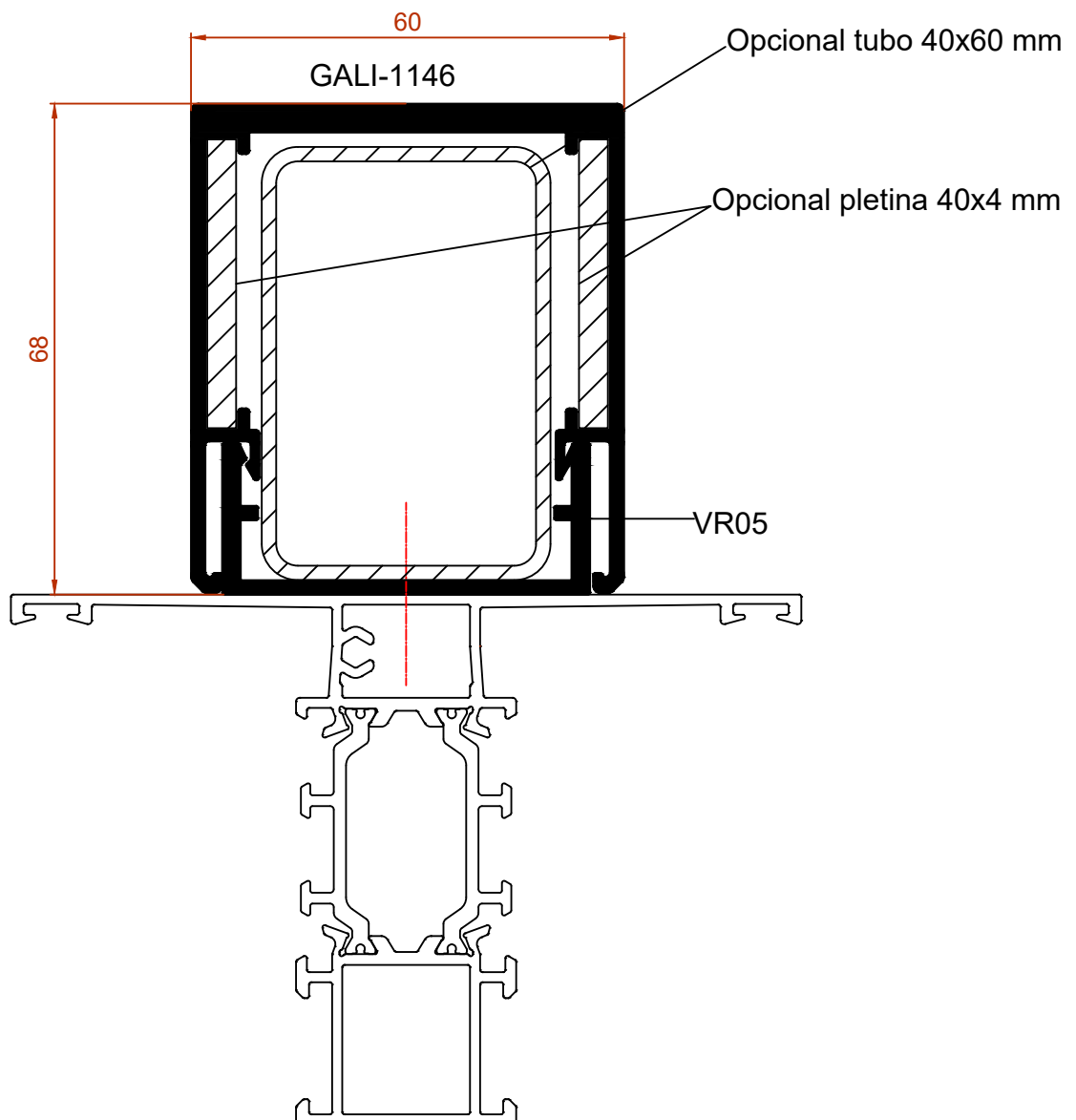





RT74 H.O. C16 - G27



## Hojas de corte Ventana 1 hoja apertura interior

RT74 H.O. C16 - Fi1

### PERFILES

Croquis	Referencia	Corte	Medida	Cant.
	74018		L	2
	74088		H	2
	74021		L-45	2
	74076 74102		H-45*	2
	0803050009		L-104,8	2
			H-104,8*	2
	Alternativa*		L	1
	74-05			

\*Medida sin condensador; caso de llevarlo reduce la altura 33 mm

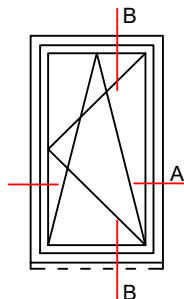
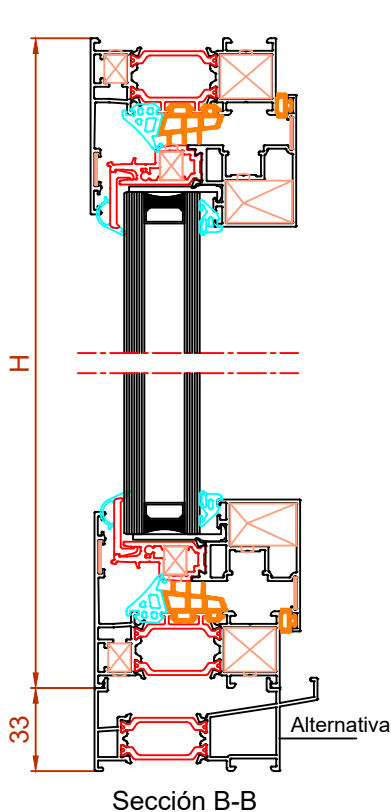

### Juntas

Ref.	Croquis	Cant.
0803150008		2xL+2xH
0803150009		2xL+2xH
0803040016		2xL+2xH
0803050002		2xL+2xH
Según acristalamiento		2xL+2xH

### VIDRIOS

Ancho	Alto	Cant.
L-125,8	H-125,8	1

### ACCESORIOS\*\*



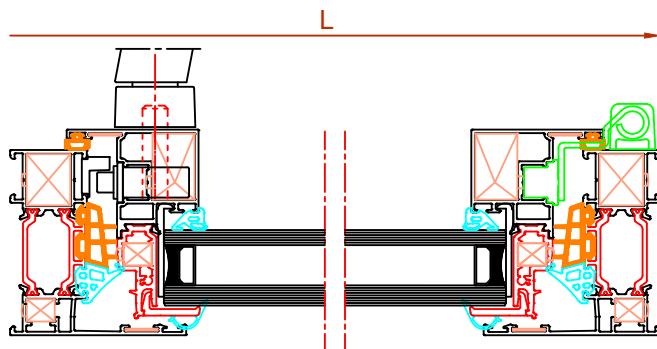





Ref.	Descripción	Cant.
1103170002	Tapa salida agua	2* (4)
0701070045	Escu. int. extru. marco	4
0701070049	Escua. int. extru. hoja	4
0701070046	Escuadras 11x9	8
0708090001	Escuadras alineami.	8



## Hojas de corte Ventana 2 hojas apertura interior

RT74 H.O. C16 - Fi2

### PERFILES

Croquis	Referencia	Corte	Medida	Cant.
	74018		L	2
	74088		H	2
	74021		L/2-25,5	4
	74076		H-45*	4
	74102			
	0803050009		L/2-85,3	4
			H-104,8*	4
	74103 + 74104		H-156*	1
	Alternativa* 74-05			L

\*Medida sin condensador; caso de llevarlo reduce la altura 33 mm

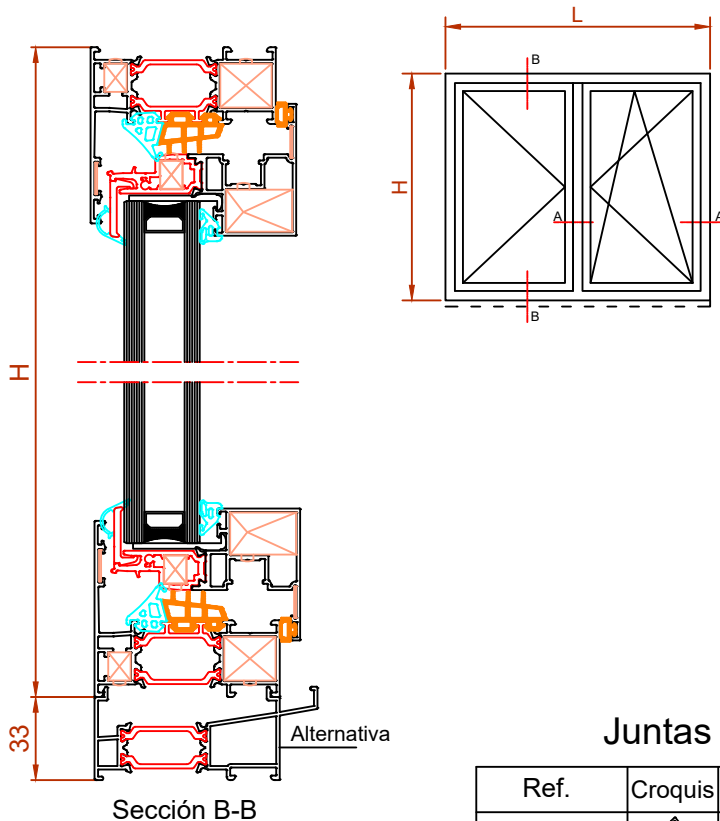

### Juntas

Ref.	Croquis	Cant.
0803150008		2xL+3xH
0803150009		2xL+3xH
0803040016		2xL+3xH
0803050002		2xL+3xH
Según acristalamiento		2xL+4xH

### VIDRIOS

Ancho	Alto	Cant.
L/2-106,3	H-125,8	2

### ACCESORIOS\*\*

Ref.	Descripción	Cant.
0701170004	Juego tapa inversora	1
1103170002	Tapa salida agua	2* (4)
0701070045	Escu. int. extru. marco	4
0701070049	Escua. int. extru. hoja	8
0701070046	Escuadras 11x9	12
0708090001	Escuadras alineami.	12

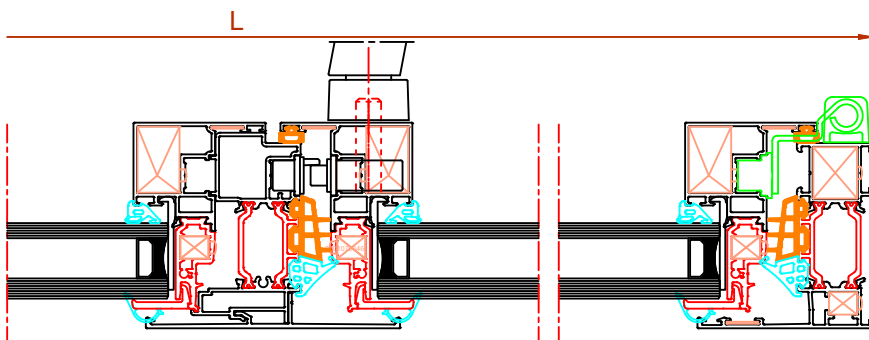





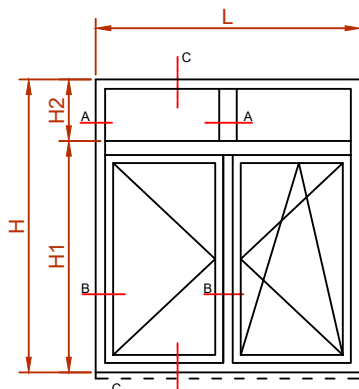
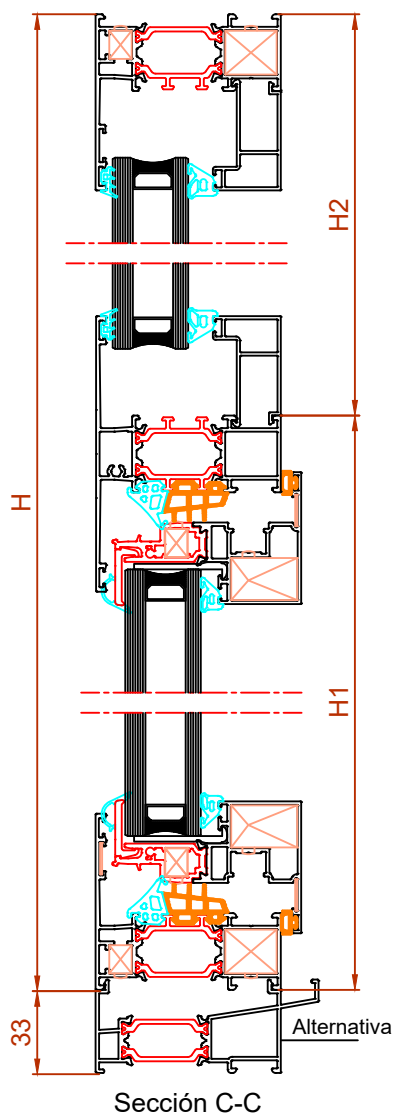











## Hojas de corte Ventana apertura interior

RT74 H.O. C16 - Fi3



### PERFILES

Croquis	Referencia	Corte	Medida	Cant.
	74018		L	2
	74088		H	2
	74021		L/2-25,5	4
	74076		H1-45*	4
	74102			
	0803050009		L/2-85,3	4
			H1-104,8*	4
	74103 + 74104		H1-156*	1
	74044		L-51	1
	74044		H2-20,5	1
	Según acristalamiento		L/2-45,75	4
			H2-109,5	4
	Alternativa*		L	1
	74-05			

\*Medida sin condensador; caso de llevarlo reduce la altura 33 mm

### Juntas

Ref.	Croquis	Cant.
0803150008		2xL+3xH
0803150009		2xL+3xH
0803040016		2xL+3xH
0803050002		2xL+3xH
Según acristalamiento		4xL+4xH

### VIDRIOS

Ancho	Alto	Cant.
L/2-106,3	H1-125,8	2
L/2-100,75	H2-85,5	2

### ACCESORIOS \*\*



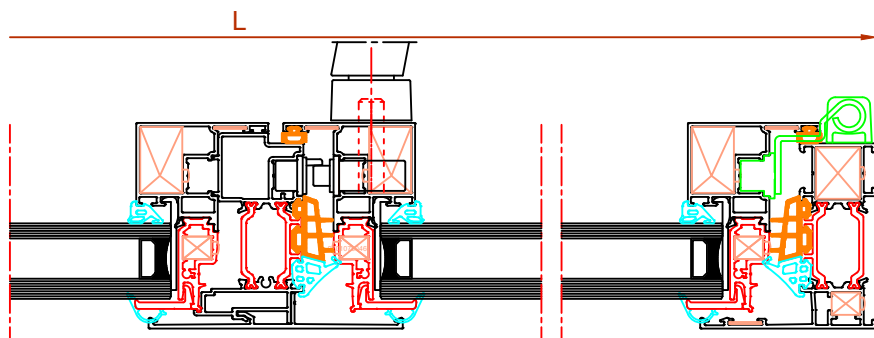
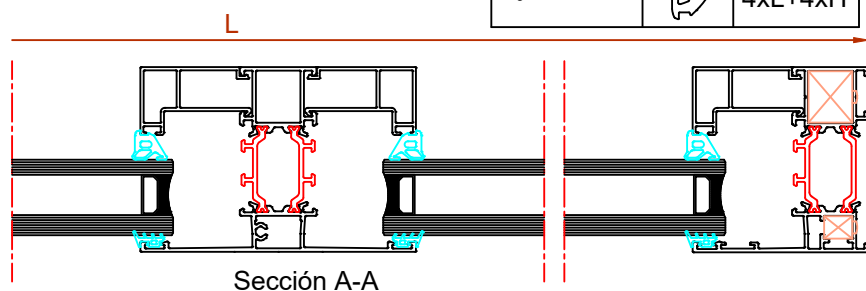









Ref.	Descripción	Cant.
0701170004	Juego tapa inversora	1
1103170002	Tapa salida agua	2* (4)
0701070045	Escua. int. extr. marco	4
0701070049	Escua. int. extru. hoja	8
0701070046	Escuadras 11x9	12
0708090001	Escuadras alineami.	12
0701070047	Tope travesaño 17	4



## Hojas de corte Ventana apertura interior

RT74 H.O. C16 - Fi4

### PERFILES

Croquis	Referencia	Corte	Medida	Cant.
	74018		L	2
	74088		H	2
	74021		L1-45	4
	74076		H-45	4
	74102			
	0803050009		L1-104,8	4
			H-104,8	4
	74044		H-51	2
	Según acristalamiento		L2	2
			H-140	2
	Alternativa*		L	1
	74-05			

\*Medida sin condensador; caso de llevarlo reduce la altura 33 mm

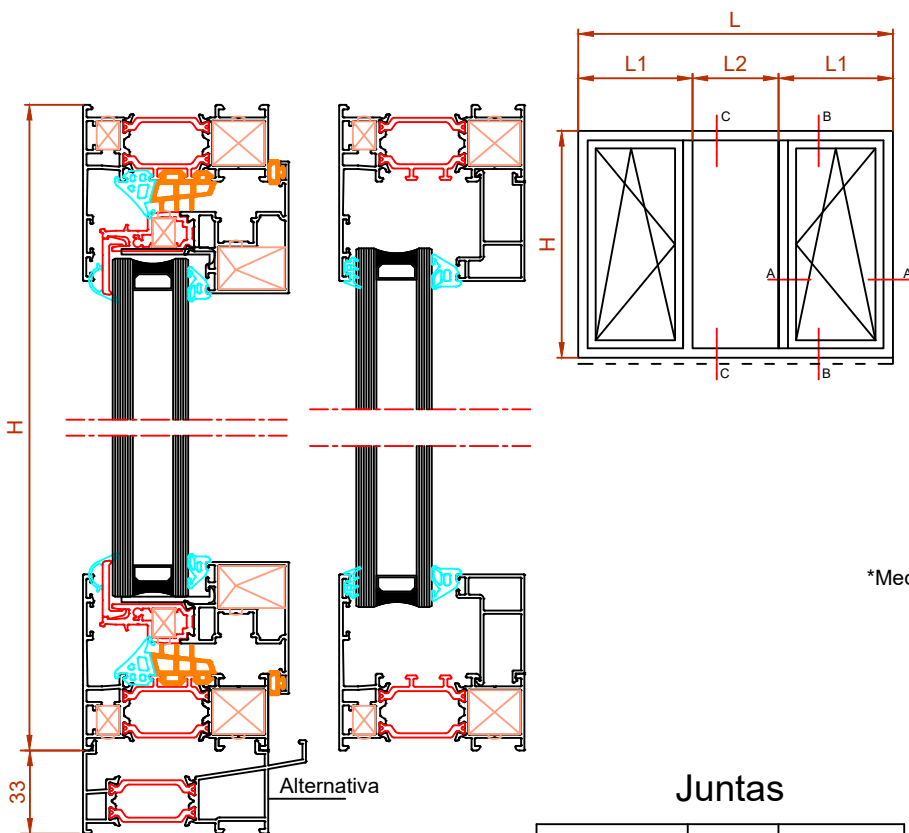

### Juntas

Ref.	Croquis	Cant.
0803150008		4xL1+4xH
0803150009		4xL1+4xH
0803040016		4xL1+4xH
0803050002		4xL1+4xH
Según acristalamiento		2xL+6xH

### VIDRIOS

Ancho	Alto	Cant.
L1-125,8	H-125,8	2
L2-55	H-116	1

### ACCESORIOS\*\*

Ref.	Descripción	Cant.
1103170002	Tapa salida agua	2* (4)
0701070045	Escua. int. extr. marco	4
0701070049	Escua. int. extru. hoja	8
0701070046	Escuadras 11x9	12
0708090001	Escuadras alineami.	12
0701070047	Tope travesaño 17	4

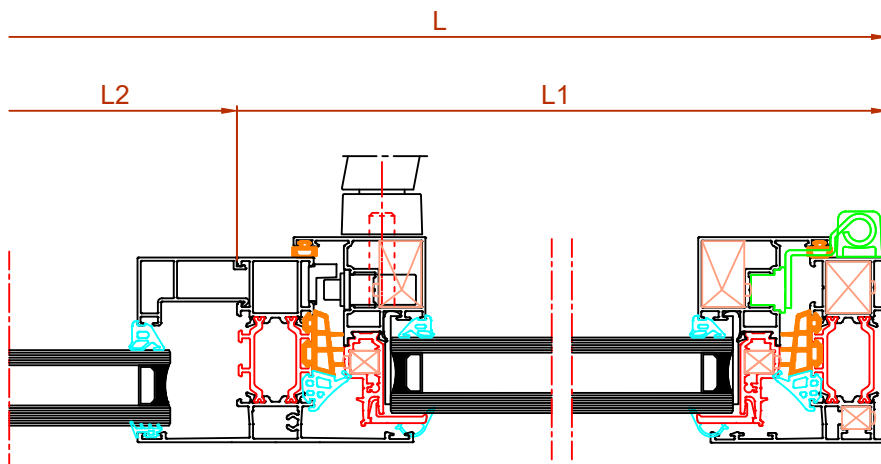















Sección A-A

## Hojas de corte Ventana apertura interior





RT74 H.O. C16 - Fi5

### PERFILES

Croquis	Referencia	Corte	Medida	Cant.
	74018		L	2
	74088		H	2
	74021		L1/2-25,5	4
	74076		H-45*	4
	74102			4
	0803050009		L1/2-85,3	4
			H-104,8*	4
	74103 + 74104		H-156*	1
	74044		H-51*	1
	Según acristalamiento		L2-30,5	4
			H-140*	4
	Alternativa* 74-05		L	1

\*Medida sin condensador; caso de llevarlo reduce la altura 33 mm

### Juntas

Ref.	Croquis	Cant.
0803150008		2xL1+3xH
0803150009		2xL1+3xH
0803040016		2xL1+3xH
0803050002		2xL1+3xH
Según acristalamiento		2xL+8xH

### VIDRIOS

Ancho	Alto	Cant.
L1/2-106,3	H-125,8	2
L2-85,5	H-116	2

### ACCESORIOS \*\*



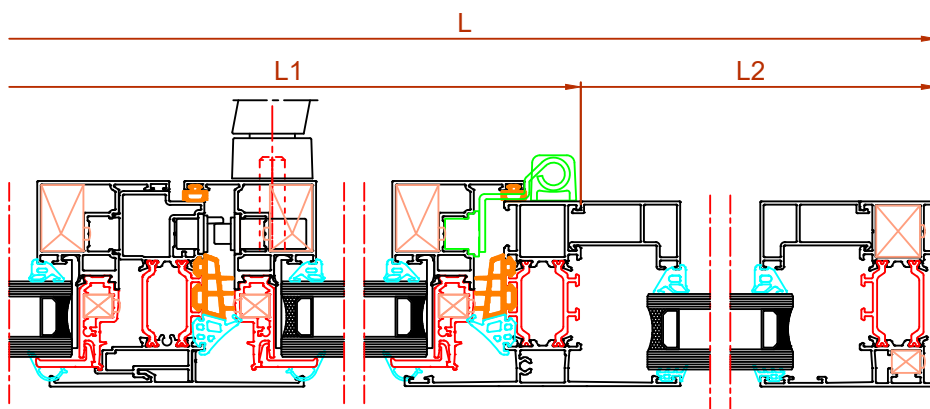
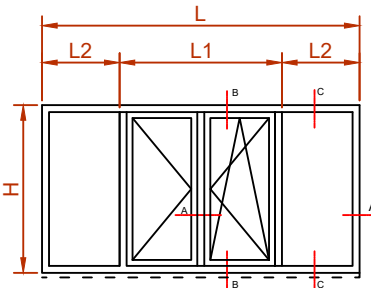
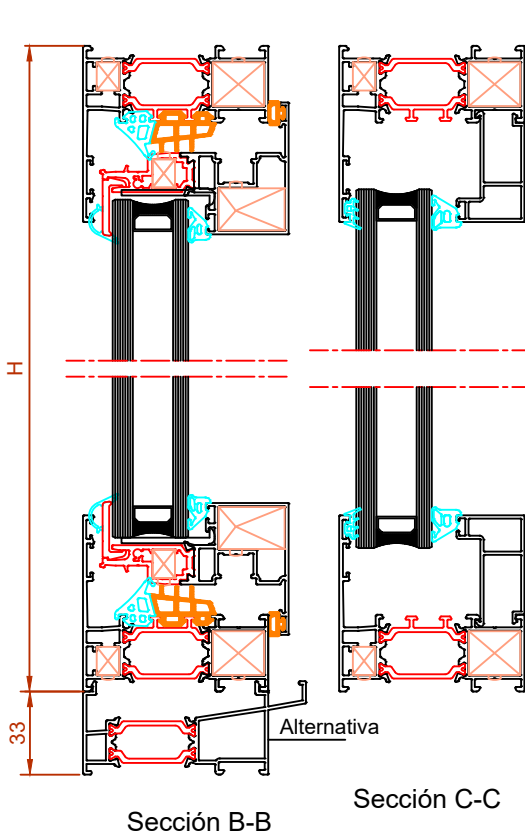





Ref.	Descripción	Cant.
0701170004	Juego tapa inversora	1
1103170002	Tapa salida agua	2* (4)
0701070045	Escua. int. extr. marco	4
0701070049	Escua. int. extru. hoja	8
0701070046	Escuadras 11x9	12
0708090001	Escuadras alineami.	12
0701070047	Tope travesaño 17	4



## Hojas de corte Ventana 1 hoja apertura interior

RT74 H.O. C16 - Fi6

### PERFILES

Croquis	Referencia	Corte	Medida	Cant.
	74014		L	2
	74089		H	2
	74021		L-82,4	2
	74076 74102		H-82,4*	2
	0803050009		L-142,2	2
			H-142,2*	2
	Alternativa*		L	1
	74-05			

\*Medida sin condensador; caso de llevarlo reduce la altura 33 mm

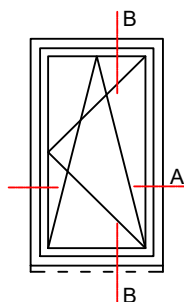
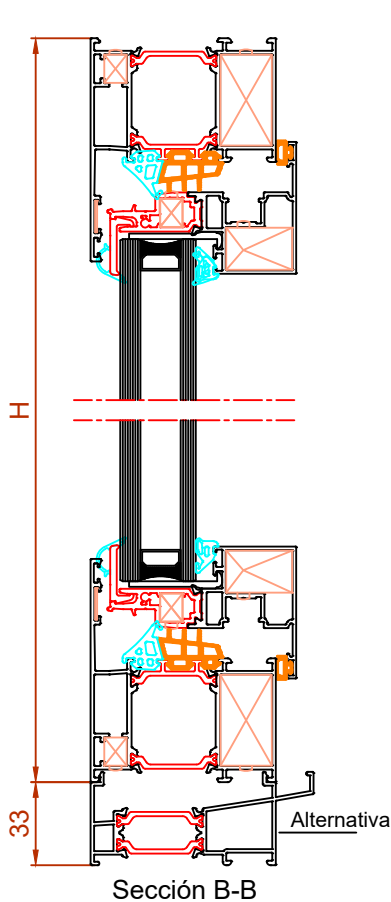

### Juntas

Ref.	Croquis	Cant.
0803150008		2xL+2xH
0803150009		2xL+2xH
0803040016		2xL+2xH
0803050002		2xL+2xH
Según acristalamiento		2xL+2xH

### VIDRIOS

Ancho	Alto	Cant.
L-163,2	H-163,2	1

### ACCESORIOS\*\*



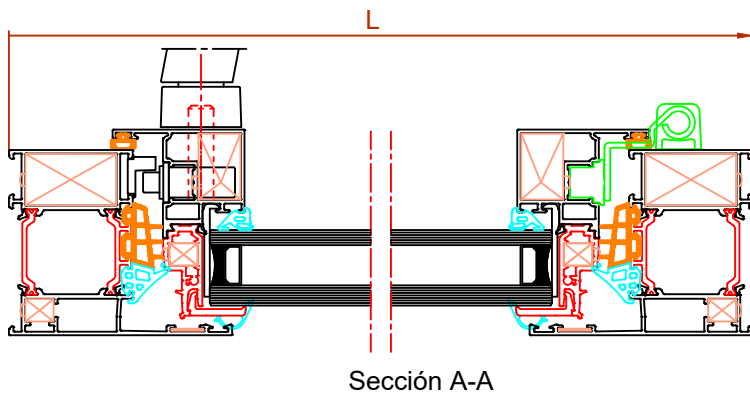





Ref.	Descripción	Cant.
1103170002	Tapa salida agua	2* (4)
0701070048	Escu. int. extru. marco	4
0701070049	Escua. int. extru. hoja	4
0701070046	Escuadras 11x9	8
0708090001	Escuadras alineami.	8



## Hojas de corte Ventana 2 hojas apertura interior

RT74 H.O. C16 - Fi7

### PERFILES

Croquis	Referencia	Corte	Medida	Cant.
	74014		L	2
	74089		H	2
	74021		L/2-44,2	4
	74076		H-82,4*	4
	74102			
	0803050009		L/2-104	4
			H-142,2*	4
	74103 + 74104		H-193,4*	1
	Alternativa* 74-05		L	1

\*Medida sin condensador; caso de llevarlo reduce la altura 33 mm

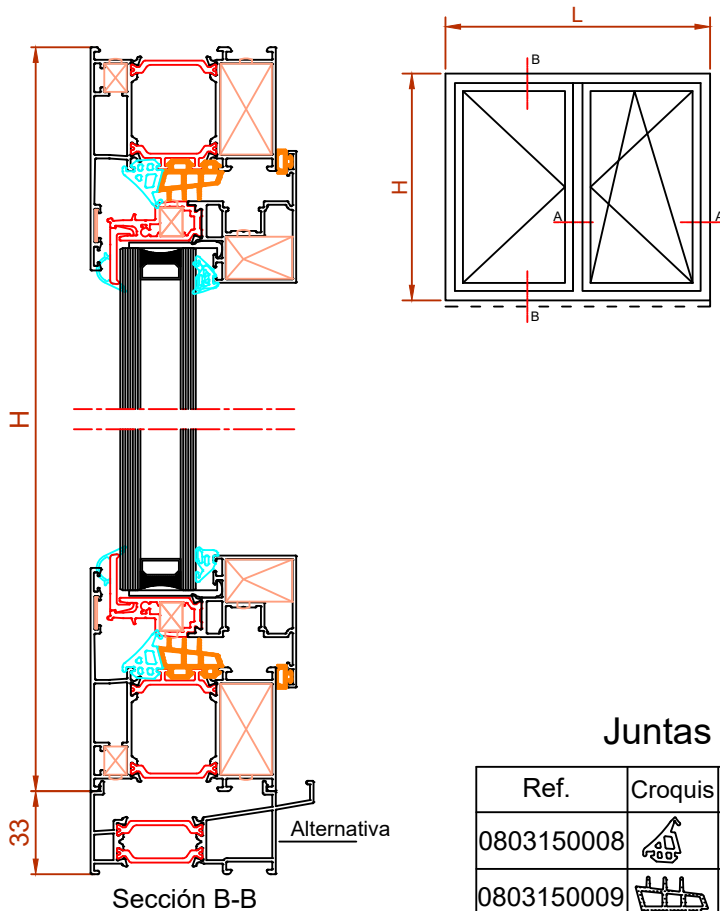

### Juntas

Ref.	Croquis	Cant.
0803150008		2xL+3xH
0803150009		2xL+3xH
0803040016		2xL+3xH
0803050002		2xL+3xH
Según acristalamiento		2xL+4xH

### VIDRIOS

Ancho	Alto	Cant.
L/2-125	H-163,2	2

### ACCESORIOS\*\*

Ref.	Descripción	Cant.
0701170004	Juego tapa inversora	1
1103170002	Tapa salida agua	2* (4)
0701070048	Escu. int. extru. marco	4
0701070049	Escua. int. extru. hoja	8
0701070046	Escuadras 11x9	12
0708090001	Escuadras alineami.	12

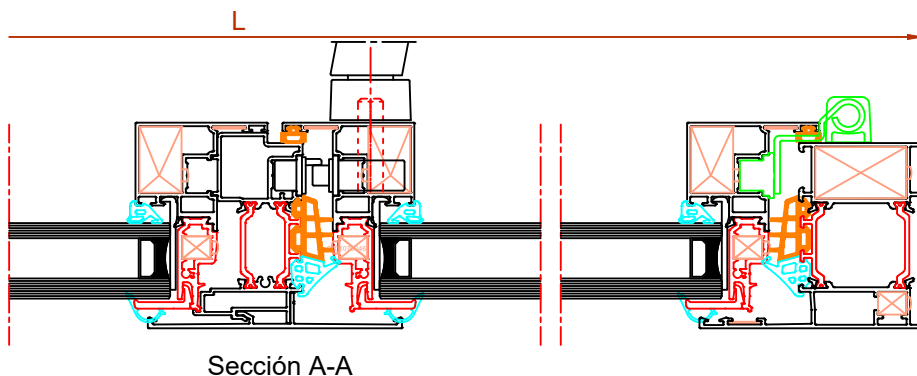







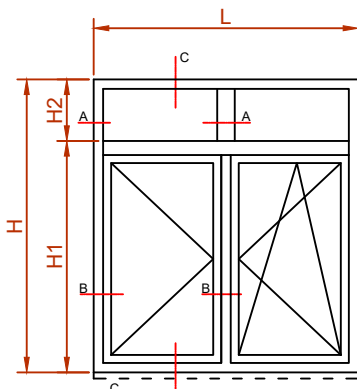
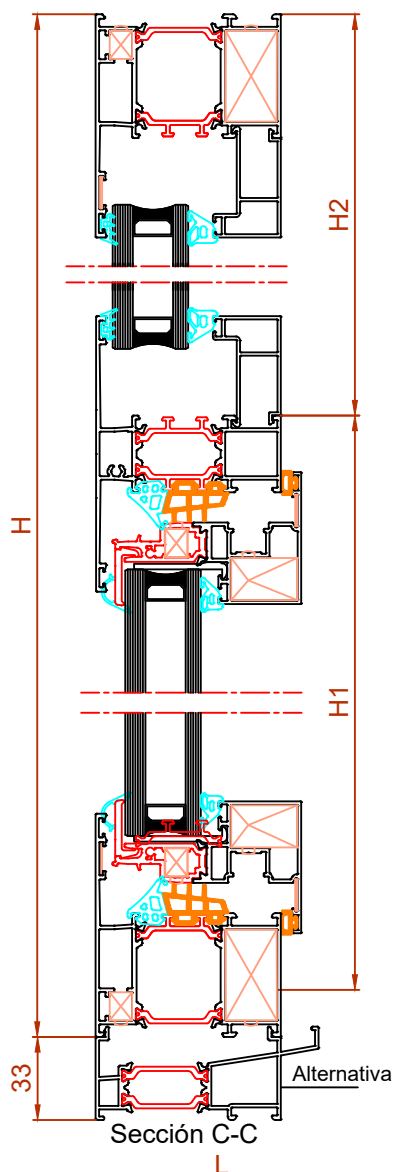











## Hojas de corte Ventana apertura interior

RT74 H.O. C16 - Fi8



### PERFILES

Croquis	Referencia	Corte	Medida	Cant.
	74014		L	2
	74089		H	2
	74021		L/2-44,2	4
	74076		H1-63,7*	4
	74102			4
	0803050009		L/2-104	4
			H1-123,5*	4
	74103 + 74104		H1-174,7*	1
	74044		L-88,4	1
	74044		H2-39,2	1
	Según acristalamiento		L/2-64,45	4
			H2-128,2	4
	Alternativa*		L	1
	74-05			

\*Medida sin condensador; caso de llevarlo reduce la altura 33 mm

### Juntas

Ref.	Croquis	Cant.
0803150008		2xL+3xH
0803150009		2xL+3xH
0803040016		2xL+3xH
0803050002		2xL+3xH
Según acristalamiento		4xL+4xH

### VIDRIOS

Ancho	Alto	Cant.
L/2-125	H1-144,5	2
L/2-119,45	H2-104,2	2

### ACCESORIOS \*\*

Ref.	Descripción	Cant.
0701170004	Juego tapa inversora	1
1103170002	Tapa salida agua	2* (4)
0701070048	Escua. int. extr. marco	4
0701070049	Escua. int. extru. hoja	8
0701070046	Escuadras 11x9	12
0708090001	Escuadras alineami.	12
0701070047	Tope travesaño 17	4

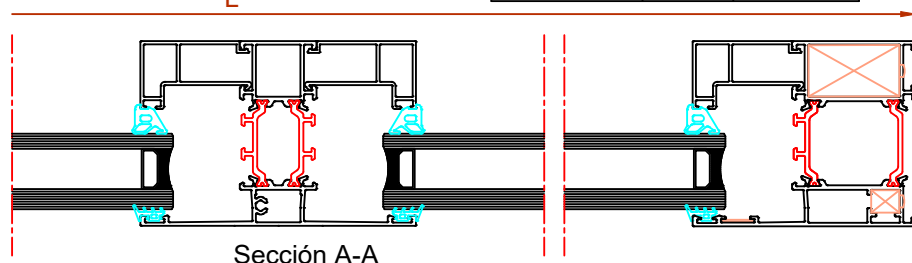

Sección A-A

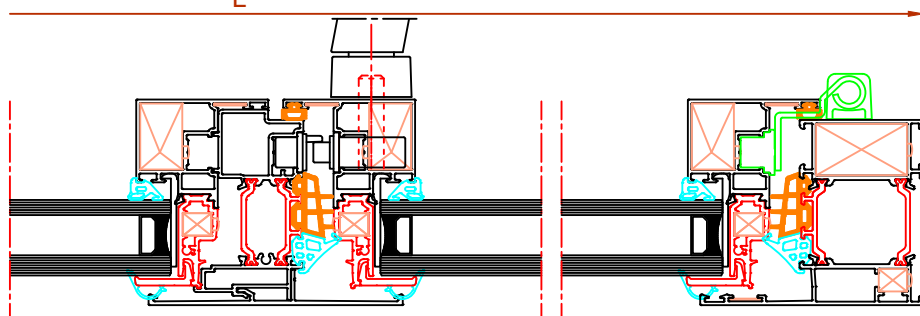













Sección B-B

## Hojas de corte Ventana apertura interior

RT74 H.O. C16 - Fi9

### PERFILES

Croquis	Referencia	Corte	Medida	Cant.
	74014		L	2
	74089		H	2
	74021		L1-63,7	4
	74076		H-82,4*	4
	74102			
	0803050009		L1-123,5 H-142,2*	4 4
	74044		H-88,4*	2
	Según acristalamiento		L2 H-177,4*	2 2
	Alternativa* 74-05		L	1

\*Medida sin condensador; caso de llevarlo reduce la altura 33 mm

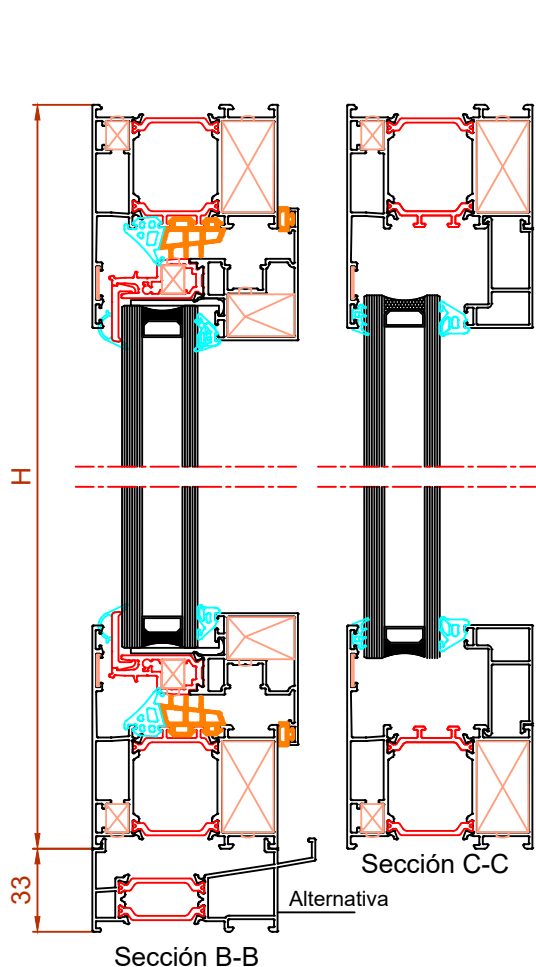

### Juntas

Ref.	Croquis	Cant.
0803150008		4xL1+4xH
0803150009		4xL1+4xH
0803040016		4xL1+4xH
0803050002		4xL1+4xH
Según acristalamiento		2xL+6xH

### VIDRIOS

Ancho	Alto	Cant.
L1-144,5	H-163,2	2
L2-55	H-153,4	1

### ACCESORIOS\*\*

Ref.	Descripción	Cant.
1103170002	Tapa salida agua	2* (4)
0701070048	Escua. int. extr. marco	4
0701070049	Escua. int. extru. hoja	8
0701070046	Escuadras 11x9	12
0708090001	Escuadras alineami.	12
0701070047	Tope travesaño 17	4

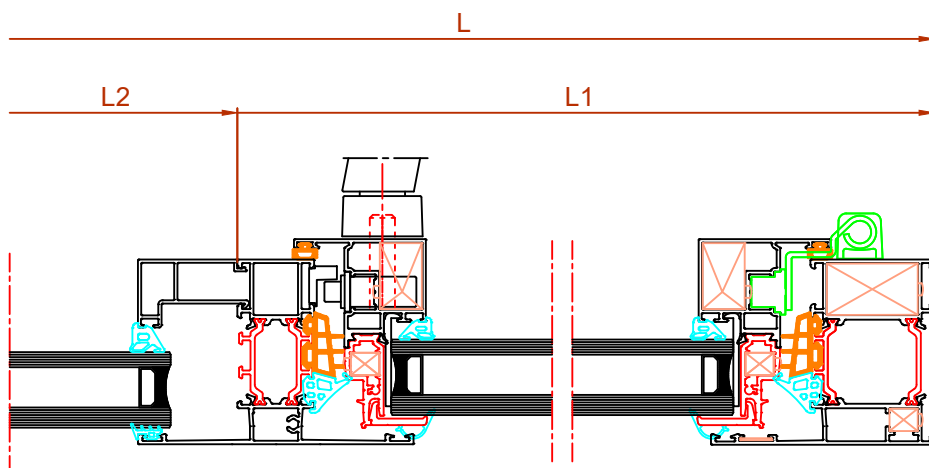

## Hojas de corte Ventana apertura interior

RT74 H.O. C16 - Fi10

### PERFILES

Croquis	Referencia	Corte	Medida	Cant.
	74014		L	2
	74089		H	2
	74021		L1/2-25,5	4
	74076		H-82,4*	4
	74102			
	0803050009		L1/2-85,3	4
			H-142,2*	4
	74103 +		H-193,4*	1
	74104			
	74044		H-88,4*	1
	Según acristalamiento		L2-49,2	4
			H-177,4*	4
	Alternativa*		L	1
	74-05			

\*Medida sin condensador; caso de llevarlo reduce la altura 33 mm

### Juntas

Ref.	Croquis	Cant.
0803150008		2xL1+3xH
0803150009		2xL1+3xH
0803040016		2xL1+3xH
0803050002		2xL1+3xH
Según acristalamiento		2xL+8xH

### VIDRIOS

Ancho	Alto	Cant.
L1/2-106,3	H-163,2	2
L2-104,2	H-153,4	2

### ACCESORIOS \*\*



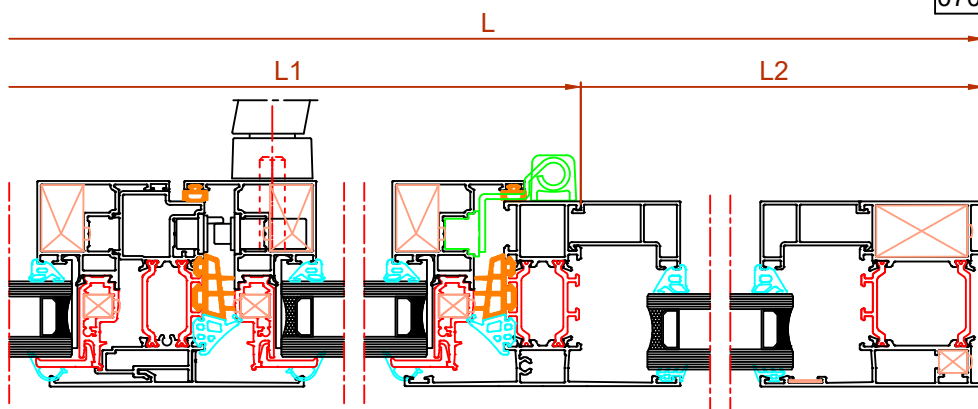
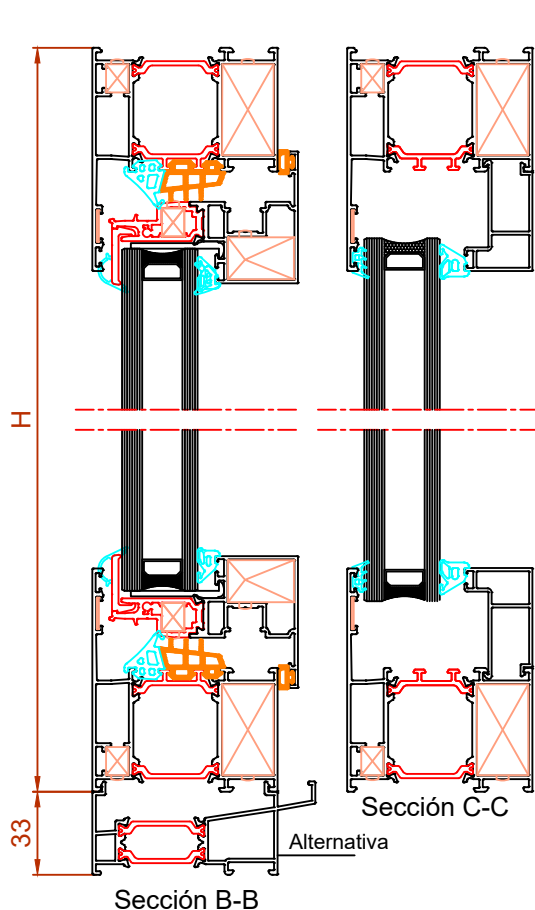









Ref.	Descripción	Cant.
0701170004	Juego tapa inversora	1
1103170002	Tapa salida agua	2* (4)
0701070048	Escua. int. extr. marco	4
0701070049	Escua. int. extru. hoja	8
0701070046	Escuadras 11x9	12
0708090001	Escuadras alineami.	12
0701070047	Tope travesaño 17	4



## Hojas de corte Ventana 2 hojas apertura interior

RT74 H.O. C16 - Fi2

### PERFILES

Croquis	Referencia	Corte	Medida	Cant.
	74018		L	2
	74088		H	2
	74021		L/2-15,5	4
	74076		H-45*	3
	74102			
	74074		H-85*	1
	74077			
	0803050009		L/2-75,3	4
			H-104,8*	4
	74075		H-149*	1
	Alternativa*		L	1
	74-05			

\*Medida sin condensador; caso de llevarlo reduce la altura 33 mm

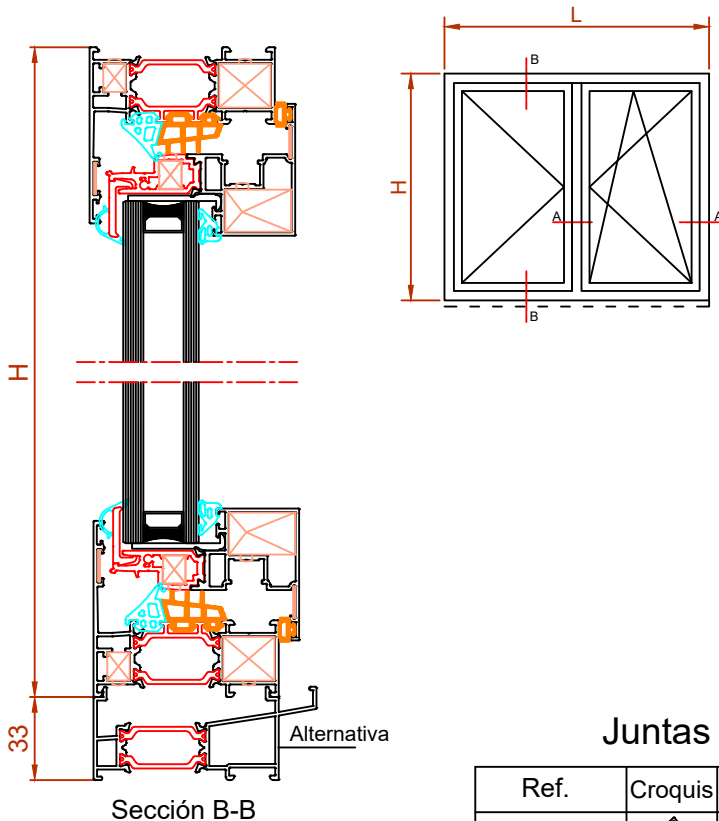

### Juntas

Ref.	Croquis	Cant.
0803150008		2xL+3xH
0803150009		2xL+3xH
0803040016		2xL+3xH
0803050002		2xL+3xH
Según acristalamiento		2xL+4xH

### VIDRIOS

Ancho	Alto	Cant.
L/2-96,3	H-125,8	2

### ACCESORIOS\*\*



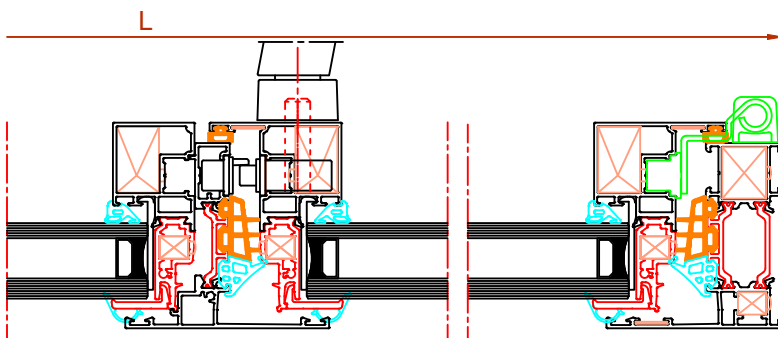









Ref.	Descripción	Cant.
0901330006	Juego tapa inversora	1
1103170002	Tapa salida agua	2* (4)
0701070045	Escu. int. extru. marco	4
0701070049	Escua. int. extru. hoja	8
0701070046	Escuadras 11x9	12
0708090001	Escuadras alineami.	12



## Hojas de corte Ventana 2 hojas apertura interior

RT74 H.O. C16 - Fi2

### PERFILES

Croquis	Referencia	Corte	Medida	Cant.
	74014		L	2
	74089		H	2
	74021		L/2-34,2	4
	74076		H-82,4*	3
	74102			
	74074		H-122,4*	1
	74077			
	0803050009		L/2-94	4
			H-142,2*	4
	74075		H-186,4*	1
	Alternativa*		L	1
	74-05			

\*Medida sin condensador; caso de llevarlo reduce la altura 33 mm

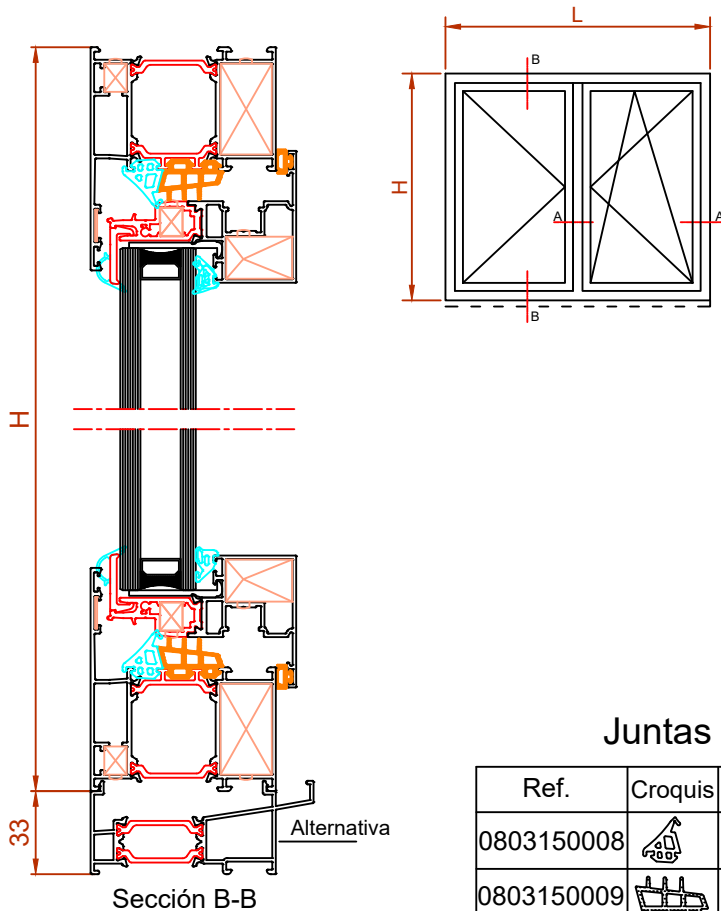

### Juntas

Ref.	Croquis	Cant.
0803150008		2xL+3xH
0803150009		2xL+3xH
0803040016		2xL+3xH
0803050002		2xL+3xH
Según acristalamiento		2xL+4xH

### VIDRIOS

Ancho	Alto	Cant.
L/2-115	H-163,2	2

### ACCESORIOS\*\*

Ref.	Descripción	Cant.
0901330006	Juego tapa inversora	1
1103170002	Tapa salida agua	2* (4)
0701070048	Escu. int. extru. marco	4
0701070049	Escua. int. extru. hoja	8
0701070046	Escuadras 11x9	12
0708090001	Escuadras alineami.	12

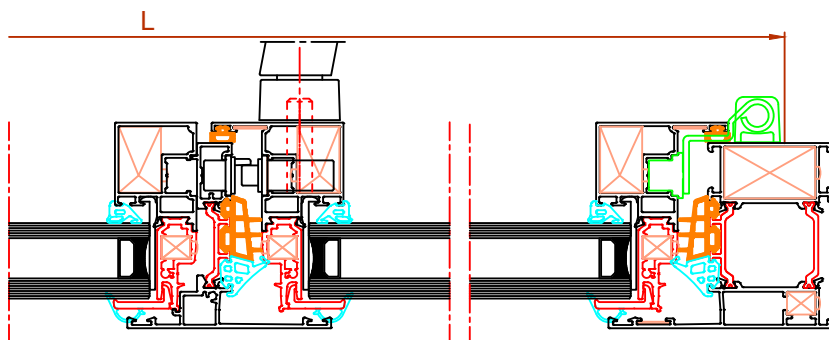

## Fabricación

RT74 H.O. C16 - H1

### 1.- CORTE PERFILES

Se cortaran los perfiles de marco y hoja a 45° en ambos extremos, respetando dimensiones y descuentos a aplicar según el modelo a fabricar. Los perfiles inversor y travesaño se cortan a 90°.

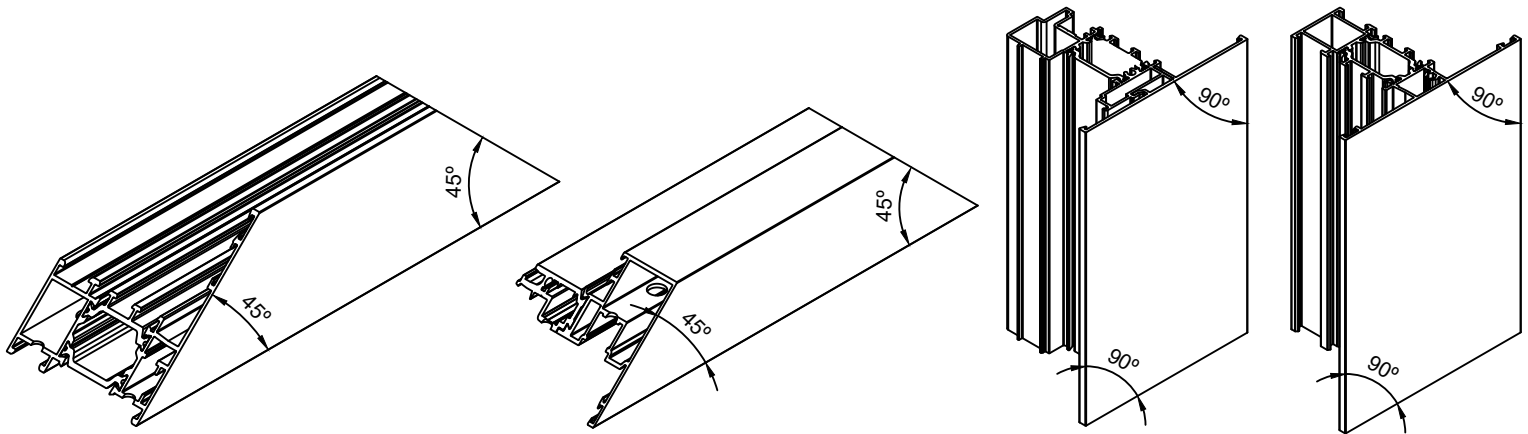

### 2.- TROQUELADO PERFILES Ver detalle troquel en pag. H7

#### Marco

Escuadras

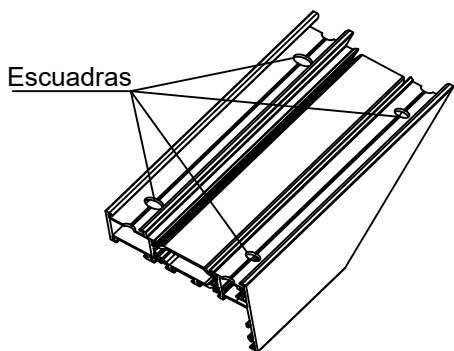

Troquelar las dos cabezas.  
(escuadra de extrusión)

Salida aguas

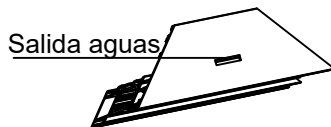

Troquelar barra inferior

Hacer en el perfil inferior

- Para  $L < 600$  mm hacer 1 desagüe situado al centro.
- Para  $600 < L < 1300$  mm hacer 2 desagües situados 150 mm de cada extremo.
- Para  $L > 1300$  mm hacer 4 desagües según esquema

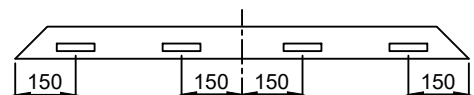

#### Hoja

Escuadras

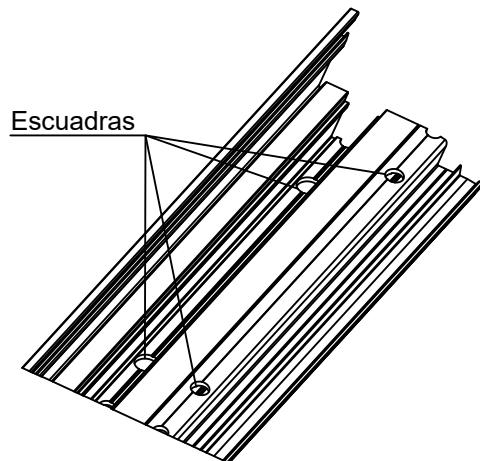

Troquelar las dos cabezas (Esc. extrusión)

#### Travesaño

Tope unión travesaño

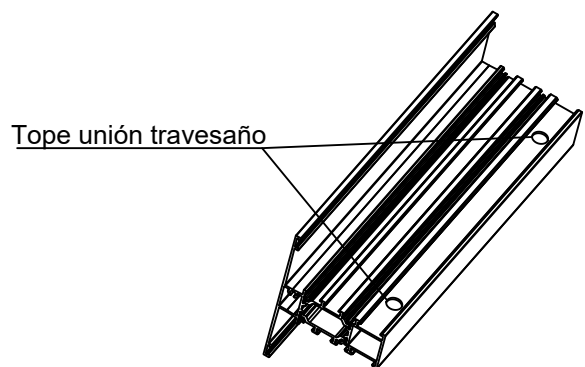

Troquelar las dos cabezas.

## Fabricación

RT74 H.O. C16 - H2

### 3.- OTROS MECANIZADOS

#### Marco

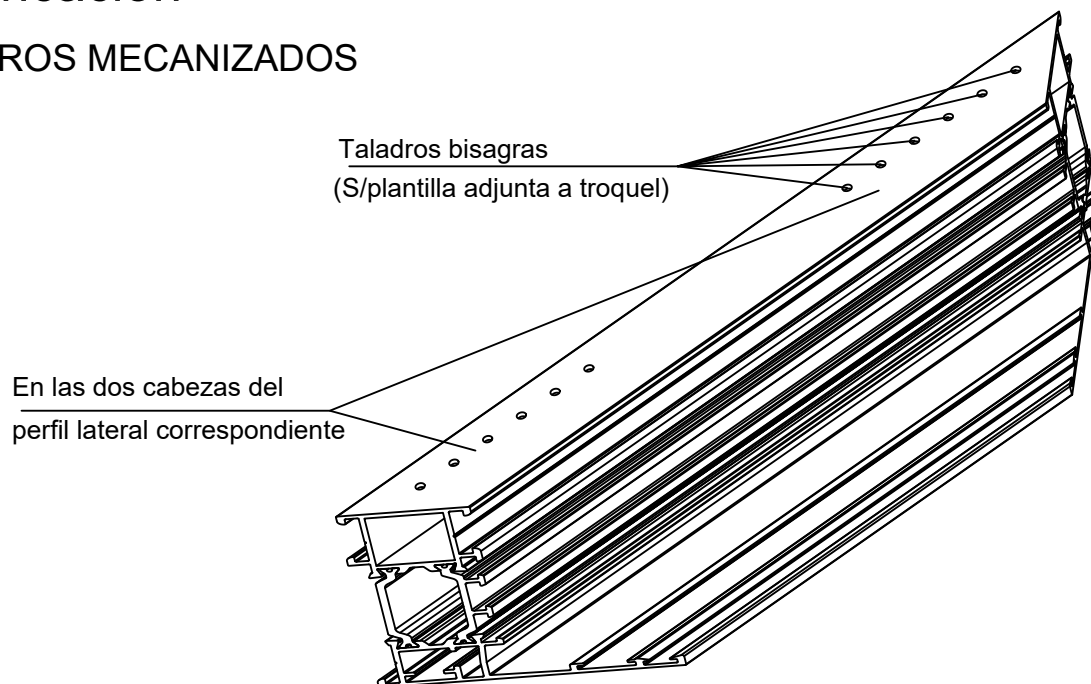

#### Hoja

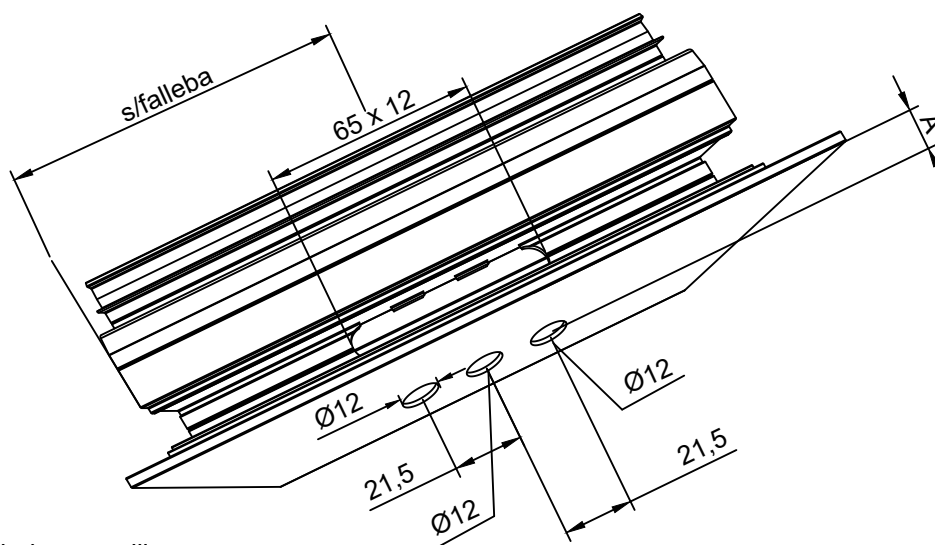

Abrir falleba y taladros manilla  
con cremonera o plantilla

Cota A = 35 abrir interior

#### Travesaño

Retestar las dos cabezas  
con grupo fresas

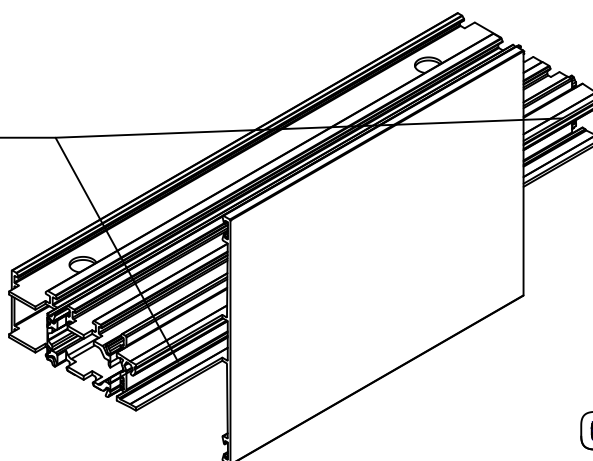

## Fabricación

RT74 H.O. C16 - H3

### 3.- OTROS MECANIZADOS

Hoja pasiva inferior y superior

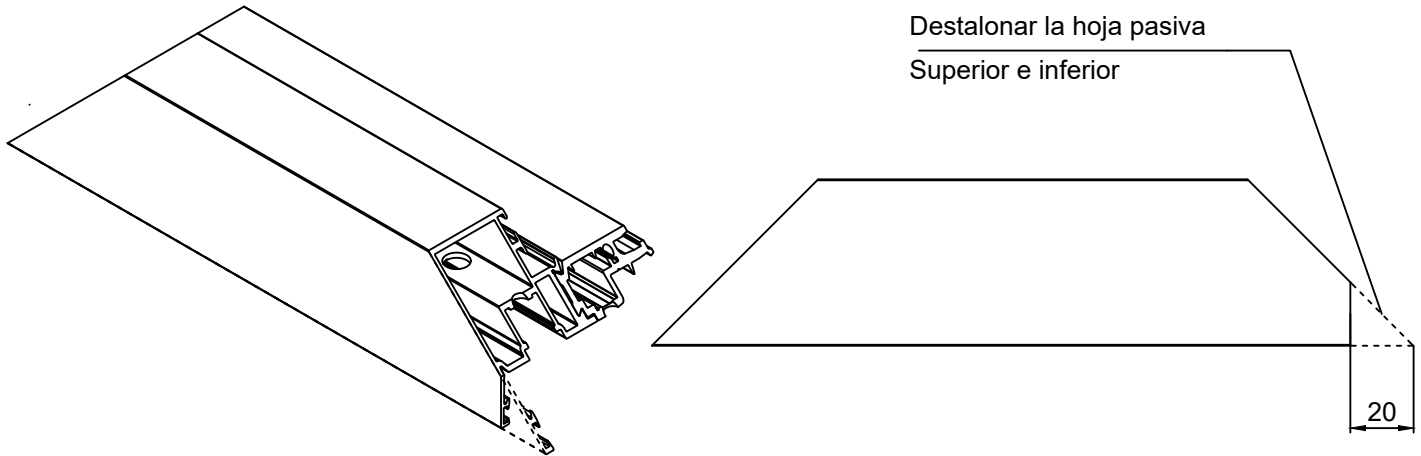

### 3.- MONTAJE ESCUADRAS

Se aplicará sellante sobre las caras del corte inglete para garantizar la estanqueidad del mismo.

A continuación se montan todas las escuadras necesarias según catalogo y se aprietan las escuadras de bloqueo.

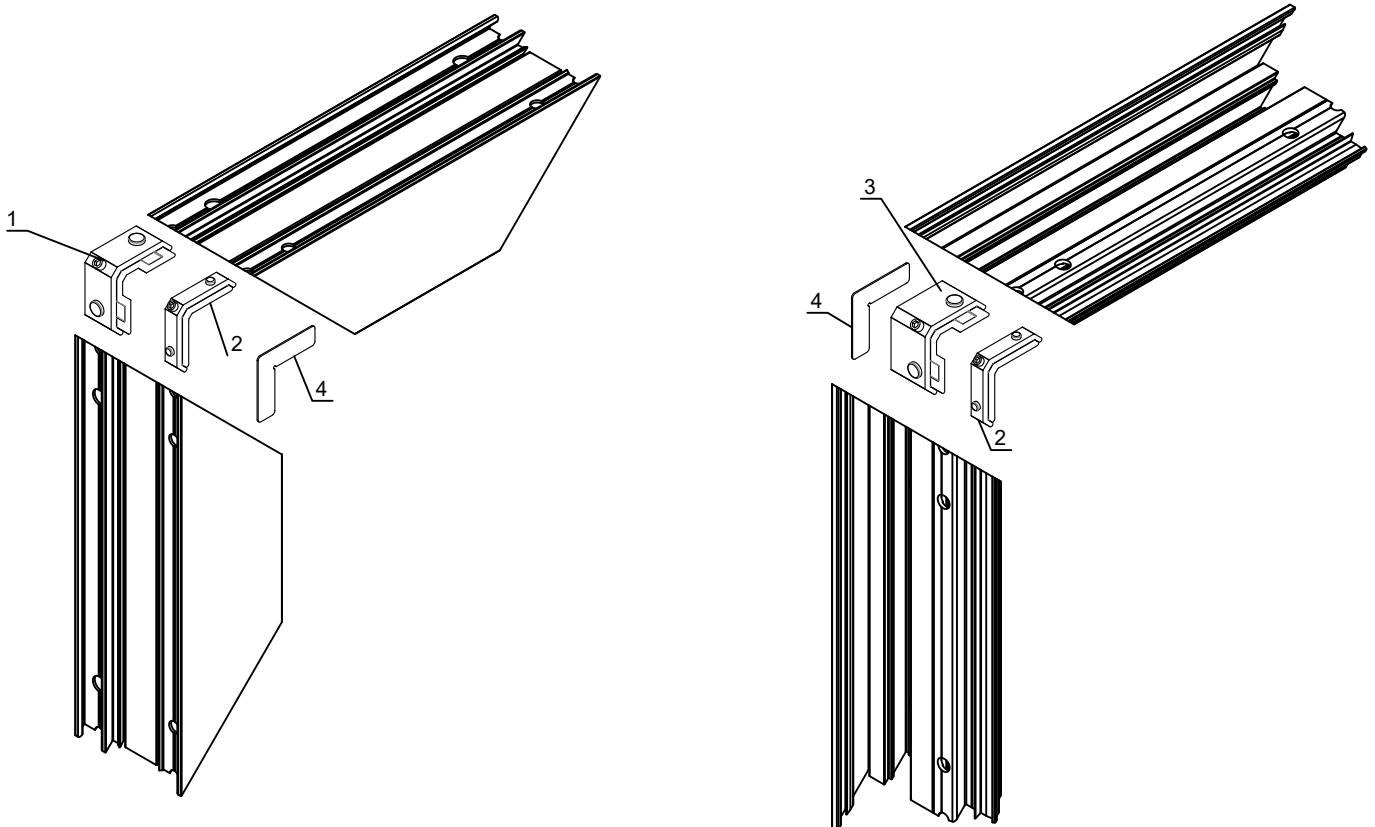

1-2-3: Escuadras bloqueo extrusión  
4: Escuadras alineamiento



## Fabricación

RT74 H.O. C16 - H4

### 4.- Colocación juntas

Colocar juntas según catalogo: Las centrales de estanqueidad y la acople térmico (en su caso) o la junta central expanso, se colocaran perimetrales continuas en los 4 lados; la exterior se recomienda no colocar en la parte superior. La interior no se colocará en el perfil hoja coincidente con el inversor.

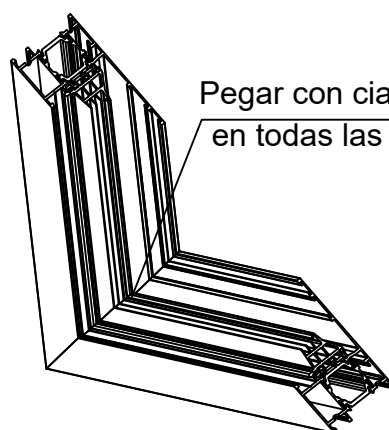
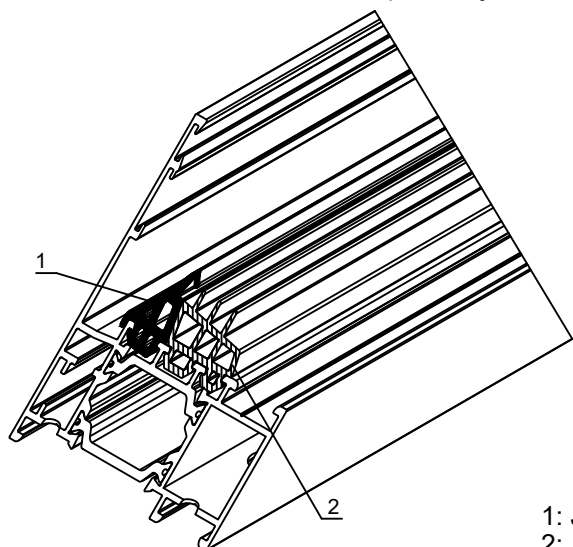

Pegar con cianocrilato  
en todas las uniones

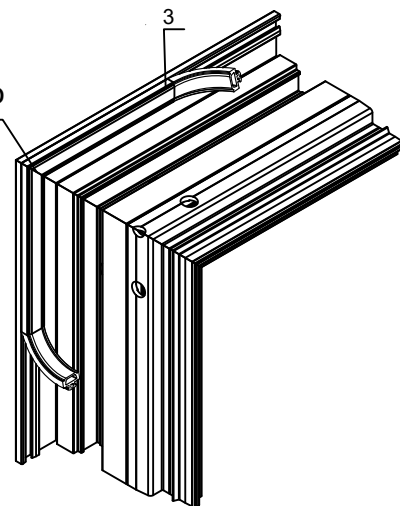

- 1: Junta estanqueidad central
- 2: Junta acoplamiento térmico
- 3: Junta central expanso
- 4: Junta interior

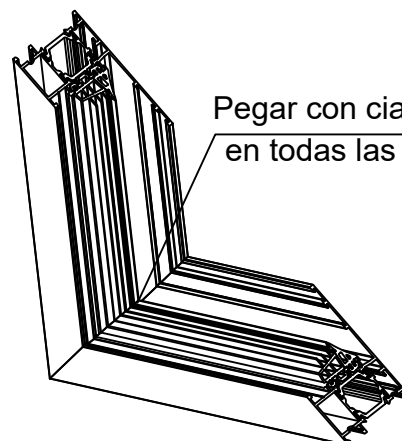
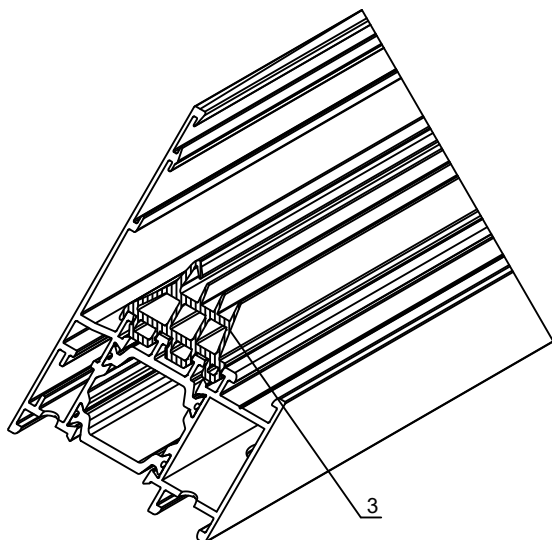

Pegar con cianocrilato  
en todas las uniones

## Fabricación

RT74 H.O. C16 - H5

### 5.- MONTAJE INVERSOR

- 1.- Aplicar sellante entre perfil inversor y tapa; atornillar tapa con tornillo de 4,2x25 DIN 7971
- 2.- Aplicar sellante en la pestaña exterior del perfil inversor en contacto con el perfil hoja
- 3.- Atornillar perfil inversor a perfil hoja con tornillos de 4,2x32 cada 300-400 mm

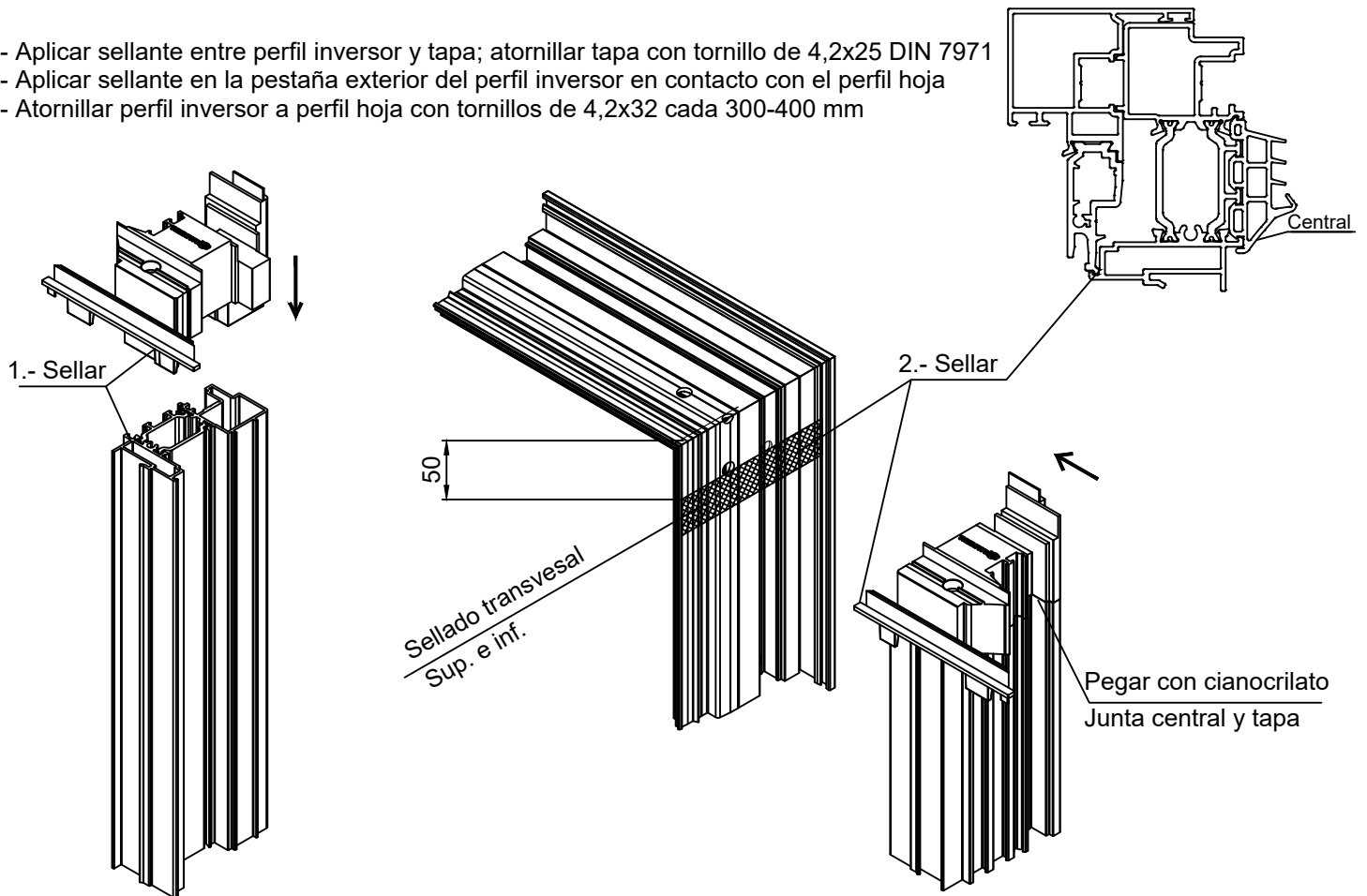

### 5A.- MONTAJE TAPETA TRAVESAÑO

Con la hoja pasiva acristalada se procede a colocar la tapeta, se inclina para, que entre la tapeta sobre el alojamiento del inversor.

Se atornilla la tapeta utilizando los mecanizados realizados, asegurándonos de que la tapeta esta en su posición, empujar hacia abajo. Tornillos de 3.5 x 15 mm.

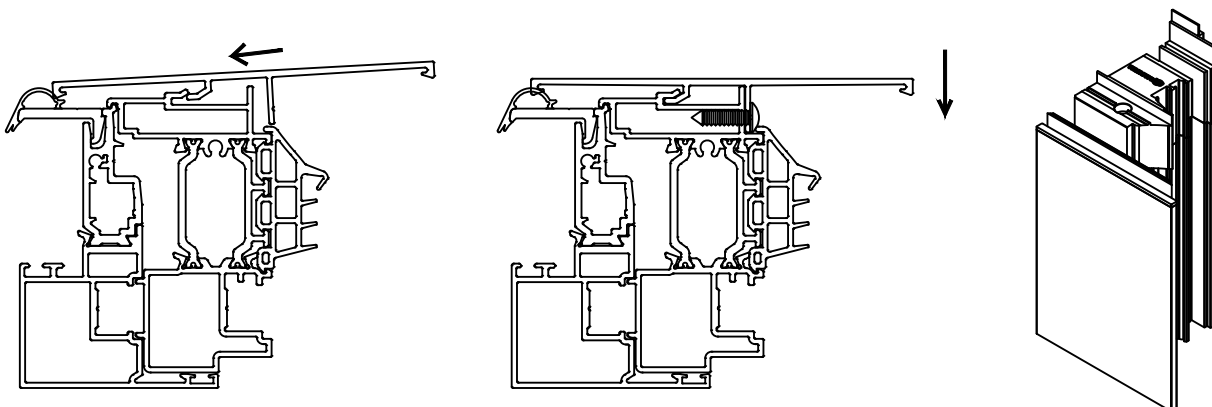

## Fabricación

RT74 H.O. C16 - H6

### 5B.- MONTAJE INVERSOR REDUCIDO

- 1.- Aplicar sellante entre perfil inversor y tapa; atornillar tapa con tornillo de 4,2x25 DIN 7971
- 2.- Aplicar sellante en la pestaña exterior del perfil inversor en contacto con el perfil hoja
- 3.- Atornillar perfil inversor a perfil hoja con tornillos de 4,2x32 cada 300-400 mm
- 4.- Colocar tapa inferior y superior en hoja pasiva.

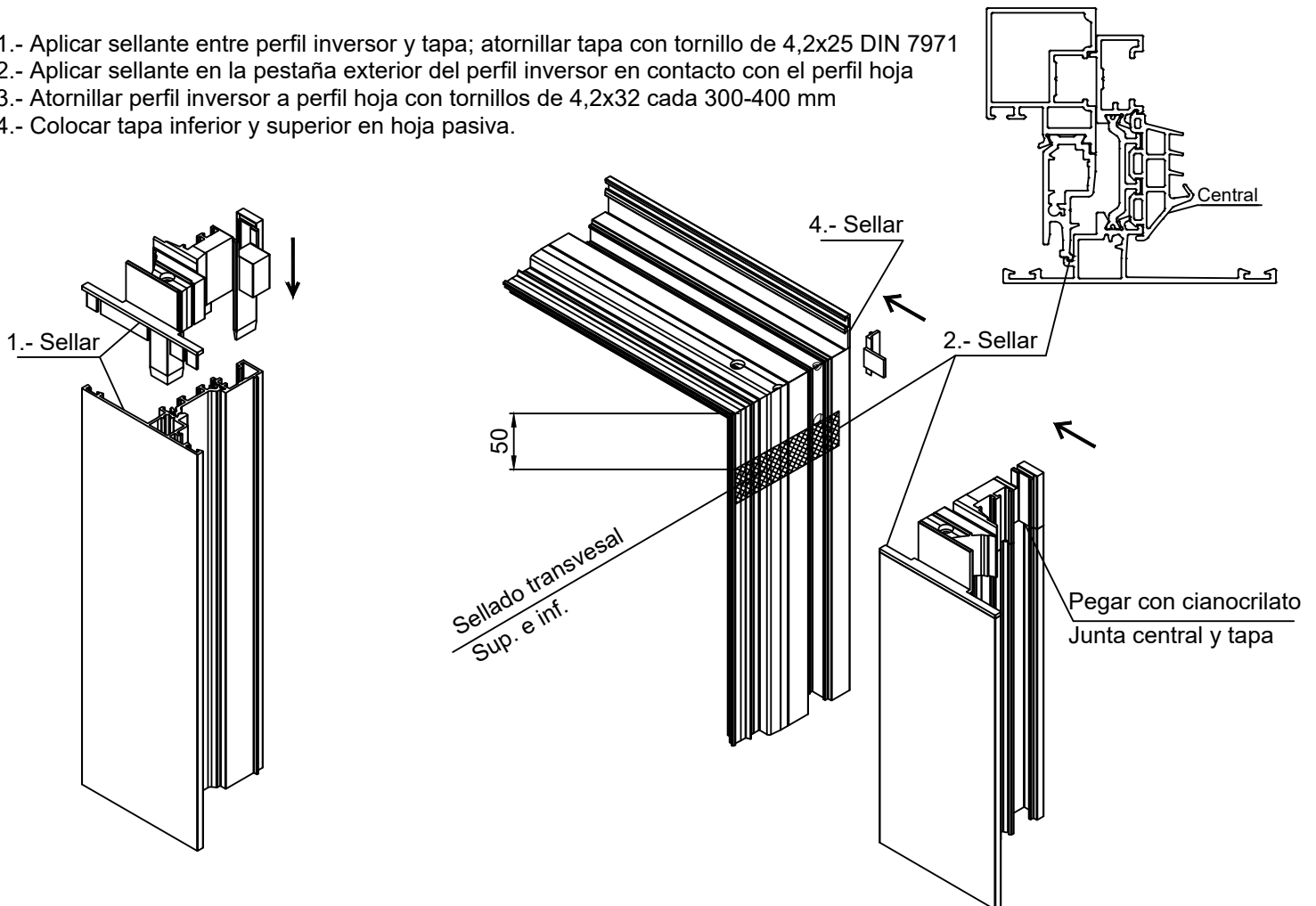

### 6A.- MONTAJE HOJAS EN MARCO

Ver hojas H5 (oscilo.activa) y H6 (pasiva) para determinar herrajes necesarios según dimensiones

Comprobar monte de hoja sobre marco de  $22.5 \text{ mm} \pm 0,5$  y la huella entre hojas, aproximándola a  $6 \text{ mm} \pm 0,5$

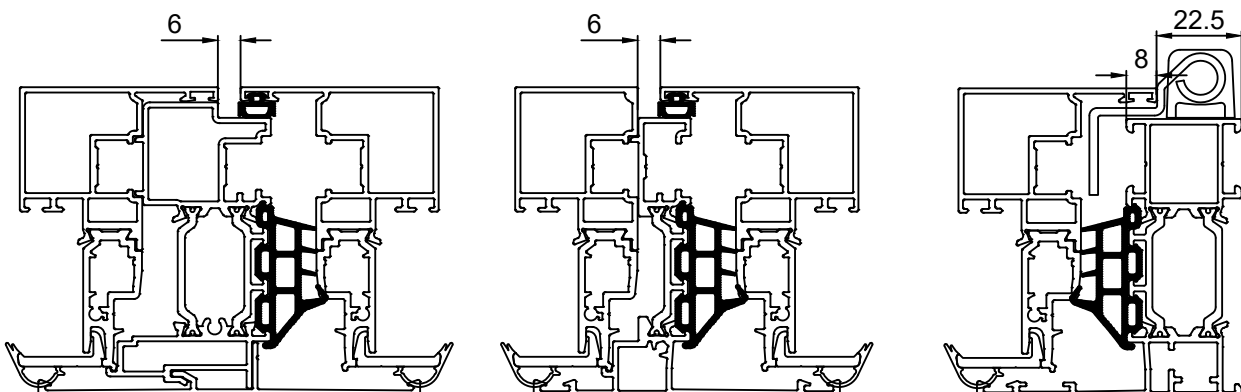

## Fabricación

### 6B.- HERRAJE OSCILOBATIENTE - HOJA ACTIVA

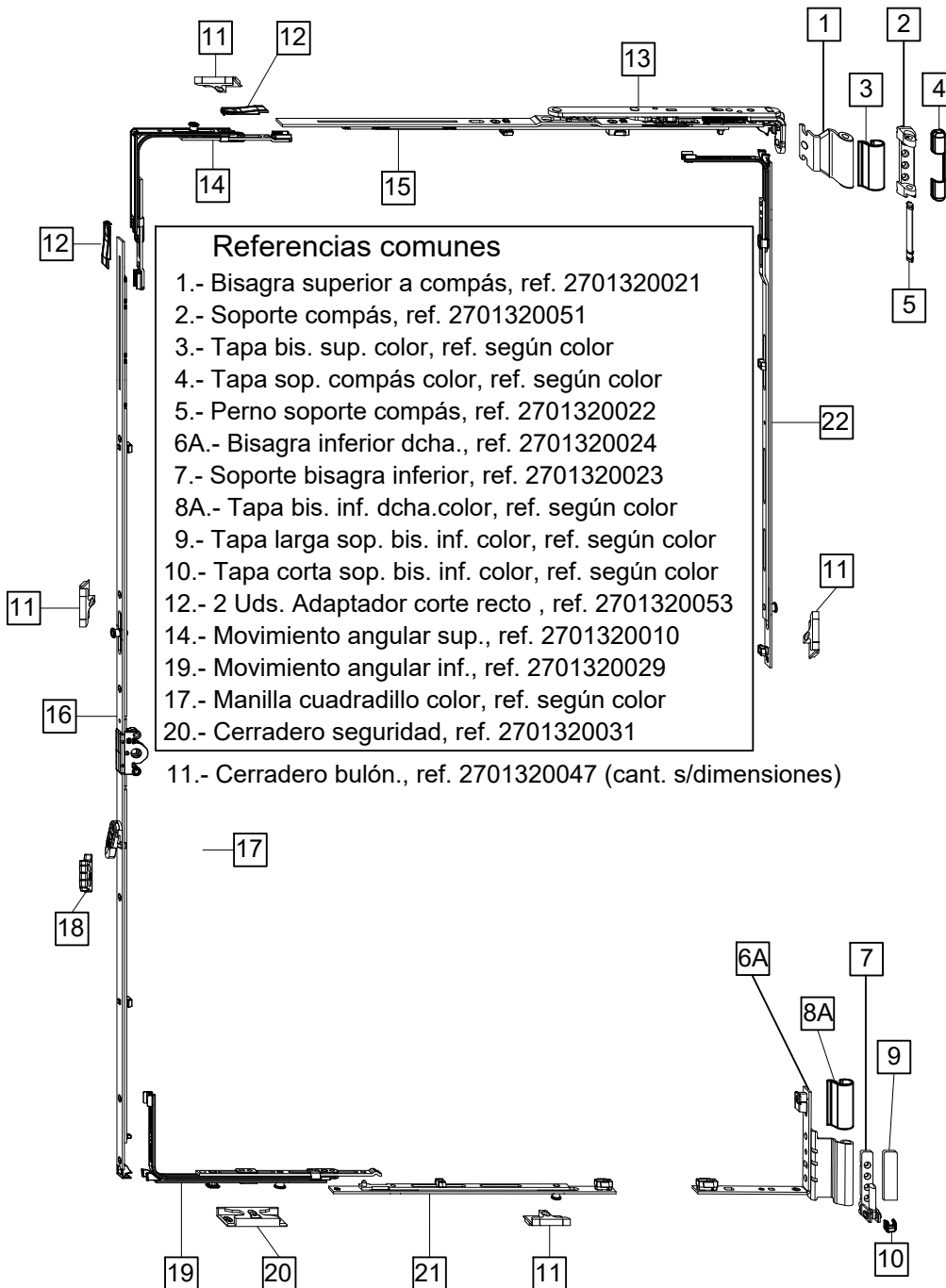

Nº	Descripción	Referencia según ancho hoja			
		401<600	601<800	801<1050	1051<1300
13	Brazo compás	2701320017	2701320018	2701320019	2701320057
15	Frontal copás	2701320013	2701320014	2701320015	2701320058
21	Cierre hor. central	—	—	2701320055	2701320055

Cant. Cerradero bulón ref. 2701320047	1	1	2	2
--	---	---	---	---

Nº	Descripción	Referencia según alto hoja										Cant. Cerrad. ref. 2701320047				
		431<660	661<800	801<840	841<1090	1091<1280	1281<1340	1341<1500	1501<1590	1591<1700	1701<1950		1951<2200	2201<2600		
16	Falleba	2701320002	2701320003	2701320004	2701320005	2701320006	2701320007	2701320008	2701320009	2701320009	2701320009	2701320009	2701320009	2701320009	2701320009	2701320009
22	Cierre lateral	—	2701320026	2701320026	2701320027	2701320027	2701320027	2701320028	2701320028	2701320028	2701320028	2701320028	2701320028	2701320028	2701320028	2701320028
18	Cerrad. elevador (32 Der.) s/ mano (33 Izq.)	2701320032	2701320032	2701320032	2701320032	2701320032	2701320032	2701320032	2701320032	2701320032	2701320032	2701320032	2701320032	2701320032	2701320032	2701320032
		—	2701320033	2701320033	2701320033	2701320033	2701320033	2701320033	2701320033	2701320033	2701320033	2701320033	2701320033	2701320033	2701320033	2701320033
		1	2	2	2	2	3	4	4	5	5	5	5	5	5	7

## Fabricación

### 6C.- HERRAJE OSCILOBATIENTE - HOJA PASIVA

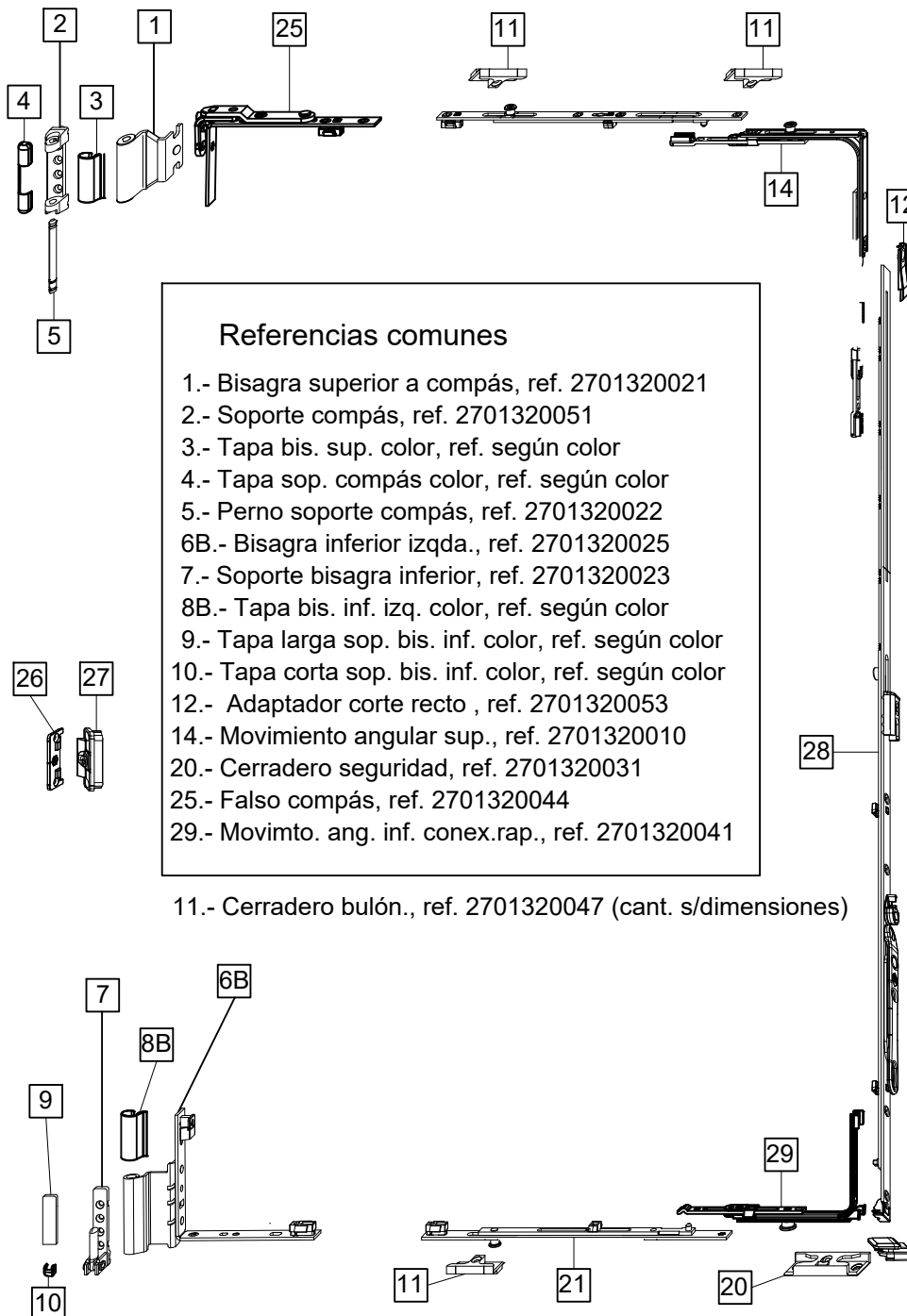

Nº	Descripción	Referencia según ancho hoja	
		401<800	801<1300
21	Cierre hor.central 2 Uds. (sup/inf.)	—	201751- - - -
Cant. Cerradero bulón ref. 2701320047		1	3

Nº	Descripción	Referencia según alto hoja								
		431<660	661<840	841<1090	1091<1340	1341<1590	1591<1700	1701<1950	1951<2200	2201<2600
28	Falleba palanca	2701320034	2701320035	2701320036	2701320037	2701320038	2701320059	2701320039	2701320040	2701320060
26	Cierre presión oculto marco Ref. 2701320045	—	—	1 Ud.	1 Ud.	1 Ud.	2 Uds.	2 Uds.	2 Uds.	3 Uds.
27	Cierre presión oculto hoja Ref. 2701320046	—	—	1 Ud.	1 Ud.	1 Ud.	2 Uds.	2 Uds.	2 Uds.	3 Uds.
Cant. Cerrad. ref. 2701320047		—	1	1	1	2	2	3	3	4

## Fabricación

RT74 H.O. C16 - H9

### 7.- ACRISTALAMIENTO

- Elegir junquillo según espesor vidrio; ver en catalogo técnico pag. D8 en adelante.
- Calzos
  - \* La anchura de los calzos será, al menos = espesor total del vidrio
  - \* Deben ser de material imputrescible y con dureza apropiada para soportar el peso y que no dañe los cantos del vidrio
- Colocar calzos de acristalamiento según esquemas abajo; la distancia a la esquina del vidrio será mínimo de 50 mm
- A fin de mejorar el aislamiento acústico, el vidrio no debe estar en contacto con los perfiles en ningún punto

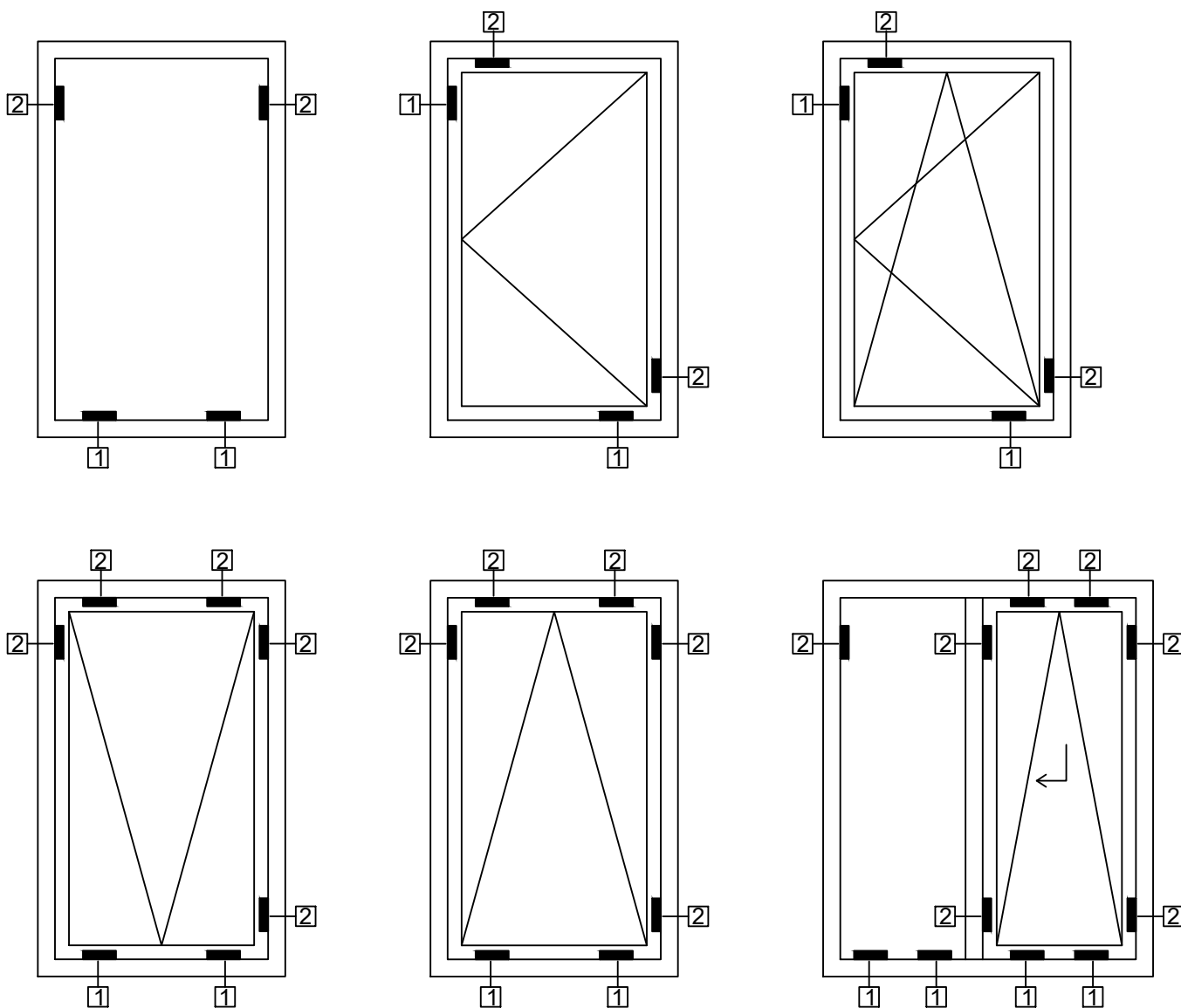

1 = Calzo de apoyo

2 = Calzo de colocación

## Fabricación

RT74 H.O. C16 - H10

### 8.- TROQUEL

Esquema de posiciones de mecanizado

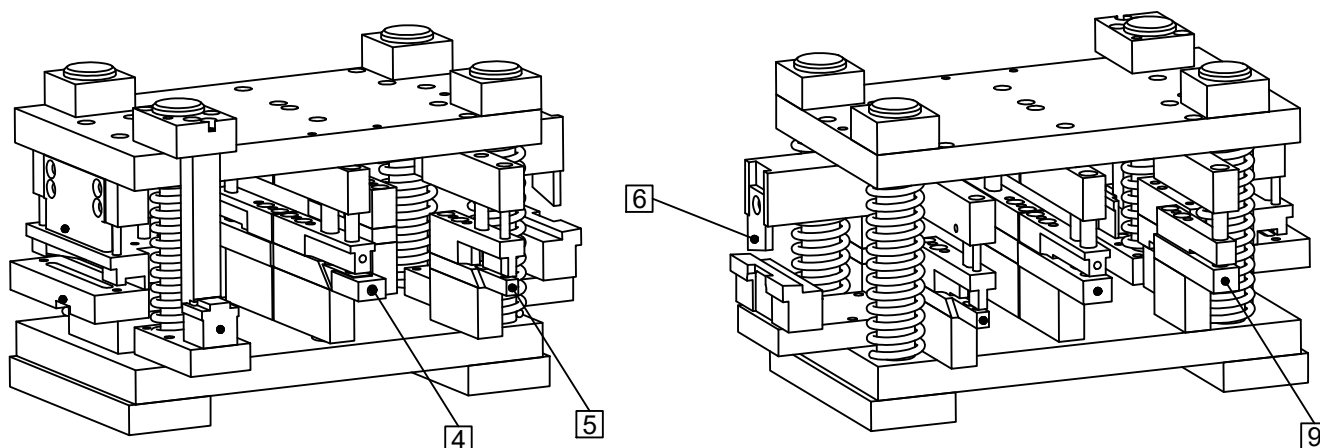

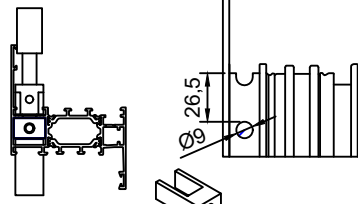
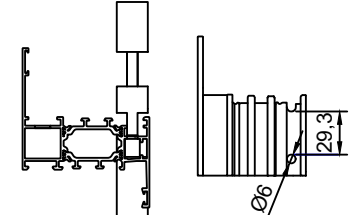
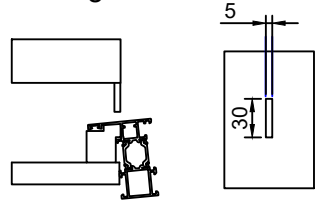
<p>4.- Esc.extrusión principal</p>  <p>En perfil hoja: - Retirar U - Acercar poliamida a la sufridera</p>
<p>5.- Esc.extrusión secundaria</p> 
<p>6.- Salida de aguas</p> 
<p>9.- Tope T.</p> 